



# PARTS CATALOGUE

**YFM125GA** (1C5V) EUROPE  
**YFM125G** (1C5U) JAPAN



1K1C5-300E1



POWER PARTS  
BY AXQUAD

YFM125GA/YFM125G  
PARTS CATALOGUE  
©2010 by Yamaha Motor Co., Ltd.  
1st edition, April 2010  
All rights reserved.  
Any reprinting or unauthorized use  
without the written permission of  
Yamaha Motor Co., Ltd.  
is expressly prohibited.  
Printed in Japan.

# FOREWORD

This Parts Catalogue is related to the parts for the model(s) on the cover page. When you are ordering replacement parts, please refer to this Parts Catalogue and quote both part numbers and part names correctly.

1. Modifications or additions which have been made after the issue of the Parts Catalogue will be announced in the Parts News.

It is advisable that you make the necessary corrections to the Parts Catalogue according to the Parts News.

2. Abbreviations

The following abbreviations are used in this Parts Catalogue.

“UR” Use specified parts number.

“UN” Use as many as needed.

“AP” Alternate Parts

“LM” Locally Made (Parts need to be ordered locally)

“F#” Frame No. (Applicable machine No.)

“O/S” Over Size

3. The number of components for assembly

- Parts, which are to be supplied in an assembly, are listed with a dot (.) in front of the part name as shown below.
- The numeral appearing to the right of each component part indicates the quantity of parts for each assembly unit.

PART NO.	DESCRIPTION	Q'TY	REMARKS
2F5-83310-60	FRONT FLASHER LIGHT ASSY	2	
115-83311-60	.BULB (6V-18W)	1	

4. Applicable colours of graphics are represented in the “REMARKS” as shown below.

PART NO.	DESCRIPTION	Q'TY	REMARKS
2N4-24110-00-X5	FUEL TANK COMP.	2	MXR
3J1-24240-10	.GRAPHIC, FUEL TANK	1	FOR MXR

5. Note that the illustrations for reference in finding parts numbers are not to be used for assembling. When assembling, please use the applicable service manual.

6. The asterisk (\*) before a reference number indicates modified items after the first edition.

# FOREWORD

7. Applicable Serial No.

Engine Serial No.

Frame Serial No.

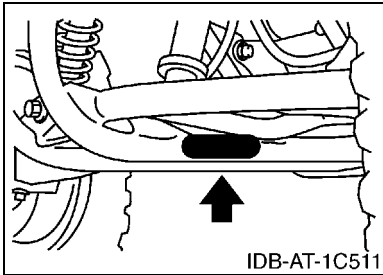
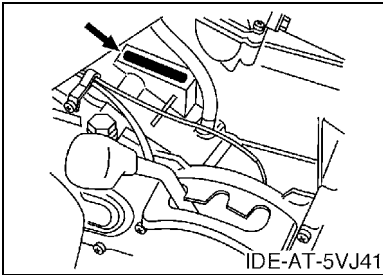

8. Applicable Colour Code (The (\*) mark shows Model colour.)

Abbreviation	Colour Name	Colour Code
DPBSN(*)	DARK PURPLISH BLUE SOLID N	0891
LGB	LOW GLOSS BLACK	0098
PDG(*)	PASTEL DEEP GREEN	00K0
YB	YAMAHA BLACK	0033

9. Quantity Column Information

Column No.	Name Of Q'ty Column	Destination
1	EUR	EUROPE
2	JPN	JAPAN



# CONTENTS

## ENGINE

CYLINDER HEAD .....	1
CRANKSHAFT & PISTON .....	2
VALVE .....	3
CAMSHAFT & CHAIN .....	4
OIL PUMP .....	5
INTAKE .....	6
CARBURETOR .....	7
EXHAUST .....	9
CRANKCASE .....	10
CRANKCASE COVER 1 .....	12
STARTER CLUTCH .....	13
CLUTCH .....	14
TRANSMISSION .....	16
SHIFT CAM & FORK .....	18

## CHASSIS

FRAME .....	19
FRONT FENDER .....	20
REAR FENDER .....	21
REAR ARM & SUSPENSION .....	22
STEERING .....	23
FRONT SUSPENSION & WHEEL .....	24
FUEL TANK .....	25
SEAT .....	26
FRONT WHEEL .....	27
REAR WHEEL .....	29
STEERING HANDLE & CABLE .....	31
STAND & FOOTREST .....	33
GUARD .....	34
GENERATOR .....	35
STARTING MOTOR .....	36
HEADLIGHT .....	37
TAILLIGHT .....	38
HANDLE SWITCH & LEVER .....	39
ELECTRICAL 1 .....	40
ELECTRICAL 2 .....	42
EMBLEM & LABEL 1 .....	43
EMBLEM & LABEL 2 .....	44

## INDEX

NUMERICAL INDEX .....	45
-----------------------	----

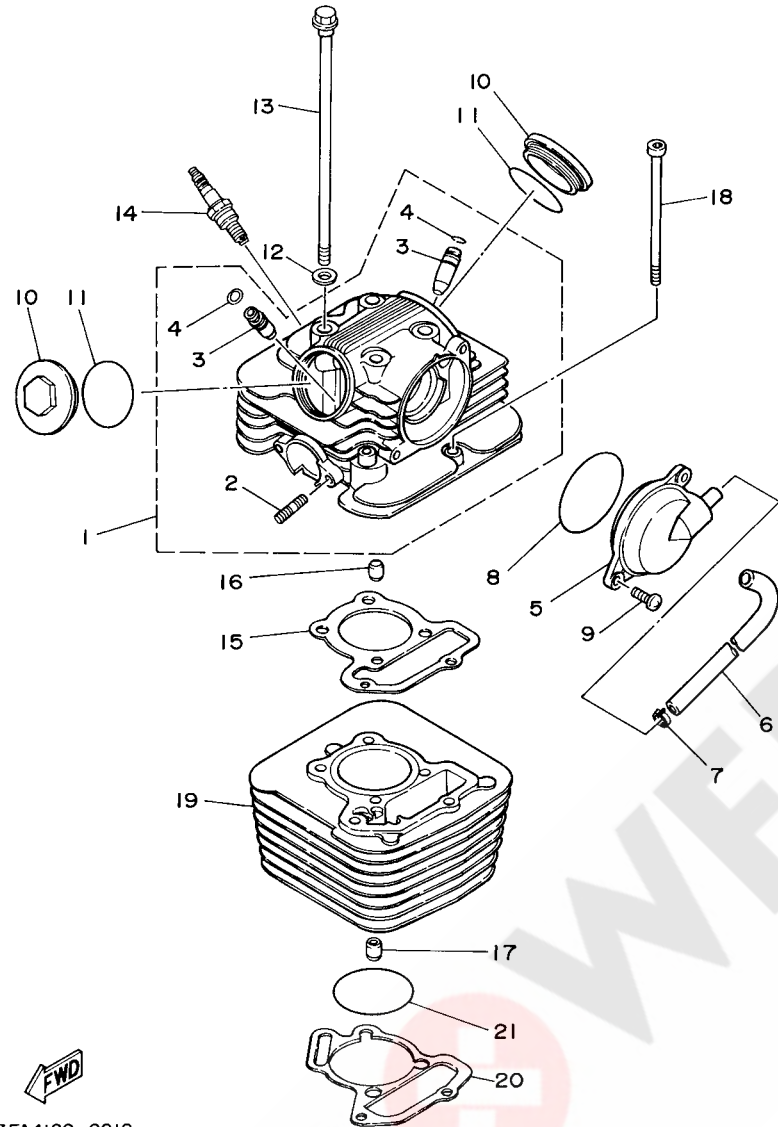
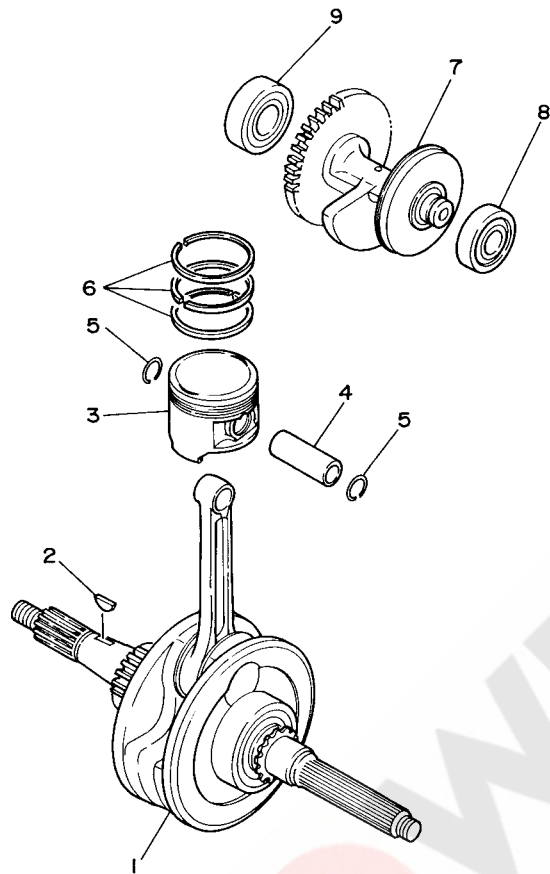

FIG. 1 CYLINDER HEAD

REF. NO.	PART NO.	DESCRIPTION	EUR	JPN		REMARKS
1	3FA-11102-04	CYLINDER HEAD ASSY	1	1		
2	90116-06541	.BOLT, STUD	2	2		
3	22F-11134-10	.GUIDE, VALVE 2	2	2		
4	93440-10109	.CIRCLIP	2	2		
5	3FA-11160-00	BREATHER ASSY	1	1		
6	3FA-11166-00	PIPE, BREATHER 1	1	1		
7	90467-13064	CLIP	1	1		
8	93210-63556	O-RING	1	1		
9	98502-06016	SCREW, PAN HEAD	2	2		
10	22F-11186-10	COVER, CYLINDER HEAD SIDE 2	2	2		
11	93210-44704	O-RING	2	2		
12	90201-08609	WASHER, PLATE	4	4		
13	90105-08181	BOLT, FLANGE	4	4		
14	94701-00366	PLUG, SPARK (NGK CR7HSA)	1			
	94703-00366	PLUG, SPARK (NGK CR7HSA)		1		
15	50M-11181-00	GASKET, CYLINDER HEAD 1	1	1		
16	99530-10114	PIN, DOWEL	2	2		
17	99530-10114	PIN, DOWEL	2	2		
18	91312-06110	BOLT	2	2		
19	3FA-11310-00	CYLINDER	1	1		
20	3FA-11351-10	GASKET, CYLINDER	1	1		
21	93210-53679	O-RING	1	1		

**FIG. 2 CRANKSHAFT & PISTON**



REF. NO.	PART NO.	DESCRIPTION	EUR	JPN			REMARKS
1	3FA-11400-00	CRANKSHAFT ASSY	1	1			
2	90280-03047	KEY, WOODRUFF	1	1			
3	3FA-11631-00-A0	PISTON (STD)	1	1			
	3FA-11636-00	PISTON (0.50MM O/S)	1	1			AP
	3FA-11638-00	PISTON (1.00MM O/S)	1	1			AP
4	22K-11633-01	PIN, PISTON	1	1			
5	93450-14088	CIRCLIP	2	2			
6	2HX-11610-00	PISTON RING SET (STD)	1	1			
	2HX-11610-20	PISTON RING SET (0.50MM O/S)	1	1			AP
	2HX-11610-40	PISTON RING SET (1.00MM O/S)	1	1			AP
7	3FA-11500-00	BALANCER ASSY	1	1			
8	93306-20215	BEARING	1	1			
9	93306-20336	BEARING	1	1			



3FA1110-9020



FIG. 3 VALVE

REF. NO.	PART NO.	DESCRIPTION	EUR	JPN	REMARKS
1	5AP-12111-01	VALVE, INTAKE	1	1	
2	5HP-12121-00	VALVE, EXHAUST	1	1	
3	2HX-12119-00	SEAL, VALVE STEM	2	2	
4	22F-12116-00	SEAT, VALVE SPRING	2	2	
5	3FA-12113-00	SPRING, VALVE INNER	2	2	
6	22F-12118-01	COTTER, VALVE	4	4	
7	22F-12117-02	RETAINER, VALVE SPRING	2	2	
8	50M-12151-00	ARM, VALVE ROCKER	2	2	
9	22F-12159-00	SCREW, VALVE ADJUSTING	2	2	
10	90170-05302	NUT	2	2	
11	22F-12156-00	SHAFT, ROCKER 2	2	2	

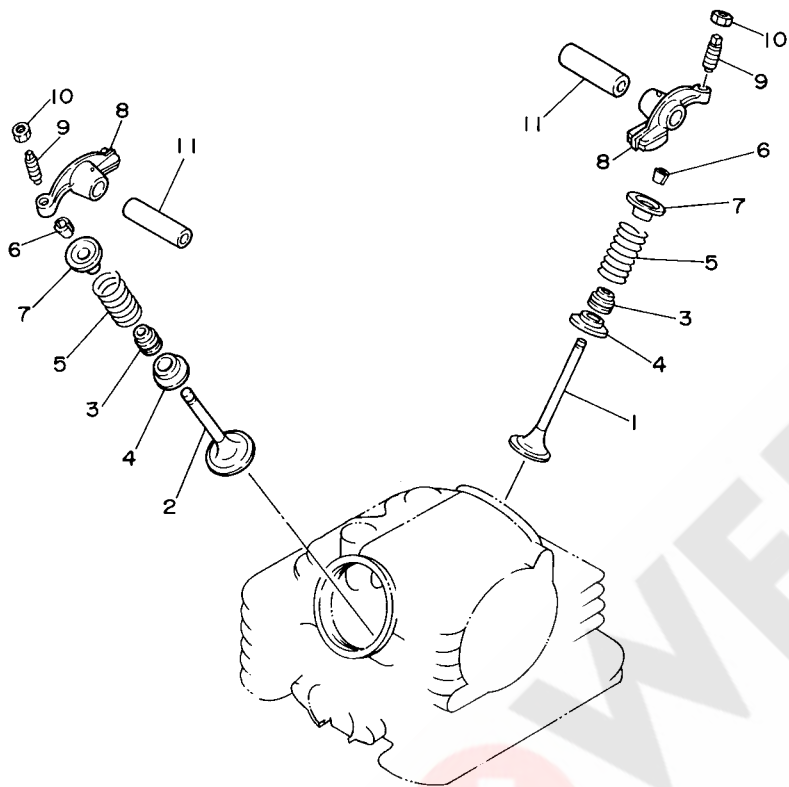

3FA1110-9030

FIG. 4 CAMSHAFT & CHAIN

REF. NO.	PART NO.	DESCRIPTION	EUR	JPN	REMARKS
1	50M-12170-01	CAMSHAFT ASSY 1	1	1	
2	50M-12176-00	SPROCKET, CAM CHAIN (28T)	1	1	
3	90387-167L5	COLLAR	1	1	
4	3FA-11145-00	PLATE, BREATHER 2	1	1	
5	90201-08048	WASHER, PLATE	1	1	
6	90101-08055	BOLT	1	1	
7	94580-25092	CHAIN (D.I.D 25)	1	1	
8	50M-12231-00	GUIDE, STOPPER 1	1	1	
9	50M-12241-00	GUIDE, STOPPER 2	1	1	
10	50M-12210-00	TENSIONER ASSY, CAM CHAIN	1	1	
11	4RF-12213-00	GASKET, TENSIONER CASE	1	1	
12	91312-06016	BOLT	2	2	
13	90430-06014	GASKET	1	1	
14	4GL-1111F-00	PLATE	1	1	
15	91312-06012	BOLT	1	1	

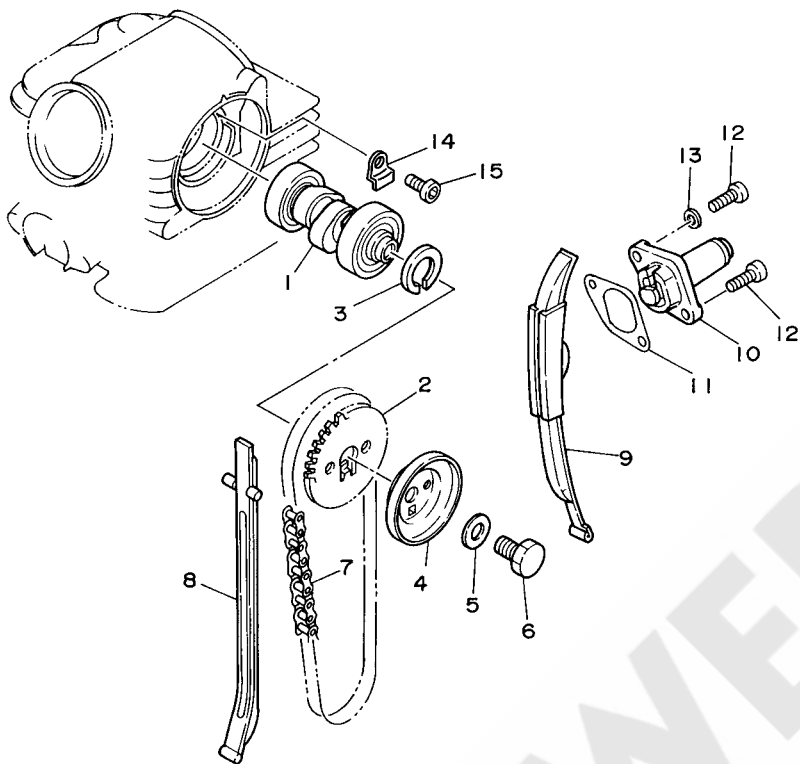

1C55100-D040

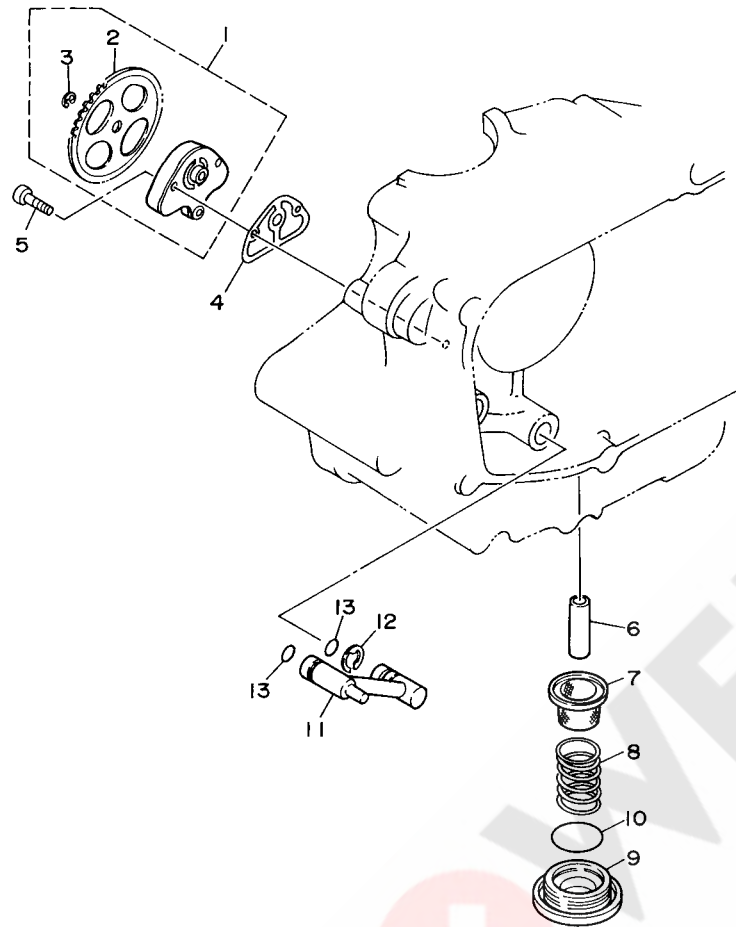

3FA1110-9050

FIG. 5 OIL PUMP

REF. NO.	PART NO.	DESCRIPTION	EUR	JPN			REMARKS
1	3FA-13300-00	OIL PUMP ASSY	1	1			
2	3FA-13325-00	.GEAR, PUMP DRIVEN	1	1			
3	99001-05600	.CIRCLIP	1	1			
4	22F-13329-01	GASKET, PUMP COVER	1	1			
5	90155-06001	SCREW, FLAT FILLISTER	2	2			
6	3Y1-13416-01	PIPE, OIL 1	1	1			
7	51Y-13411-00	STRAINER, OIL	1	1			
8	90501-18576	SPRING, COMPRESSION	1	1			
9	30X-15351-00	PLUG, DRAIN	1	1			
10	93210-347A1	O-RING	1	1			
11	3FA-13405-00	OIL PIPE COMP. 1	1	1			
12	99001-10600	CIRCLIP	1	1			
13	93210-08006	O-RING	2	2			

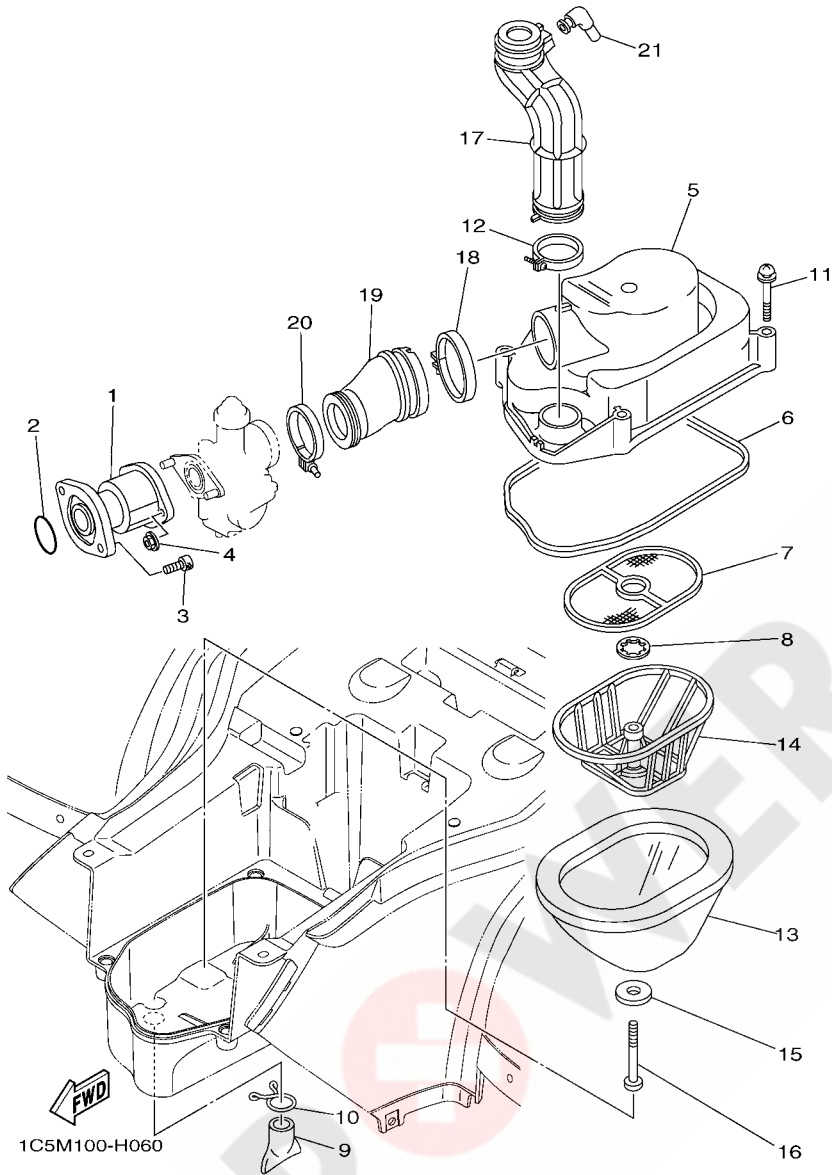

FIG. 6 INTAKE

REF. NO.	PART NO.	DESCRIPTION	EUR	JPN	REMARKS
1	3FA-13586-00	JOINT, CARBURETOR 1	1	1	
2	93210-30611	O-RING	1	1	
3	91312-06020	BOLT	2	2	
4	95702-06500	NUT, FLANGE	2	2	
5	3FA-14412-01	CAP, CLEANER CASE 1	1	1	
6	36F-14452-00	SEAL	1	1	
7	3FA-14472-00	PLATE, ELEMENT	1	1	
8	3FA-14424-00	CLIP, CAP FITTING	1	1	
9	59V-14457-00	SEAL	1	1	
10	90467-220A1	CLIP	1	1	
11	90159-05045	SCREW, WITH WASHER	4	4	
12	90450-45075	HOSE CLAMP ASSY	1	1	
13	2XJ-14451-00	ELEMENT, AIR CLEANER	1	1	
14	2XJ-14458-00	GUIDE	1	1	
15	90209-06096	WASHER	1	1	
16	98502-06060	SCREW, PAN HEAD	1	1	
17	3FA-14437-00	DUCT	1	1	
18	90460-58015	CLAMP, HOSE	1	1	
19	3FA-14453-00	JOINT, AIR CLEANER 1	1	1	
20	90450-45075	HOSE CLAMP ASSY	1	1	
21	2NL-14419-00	PIPE	1	1	

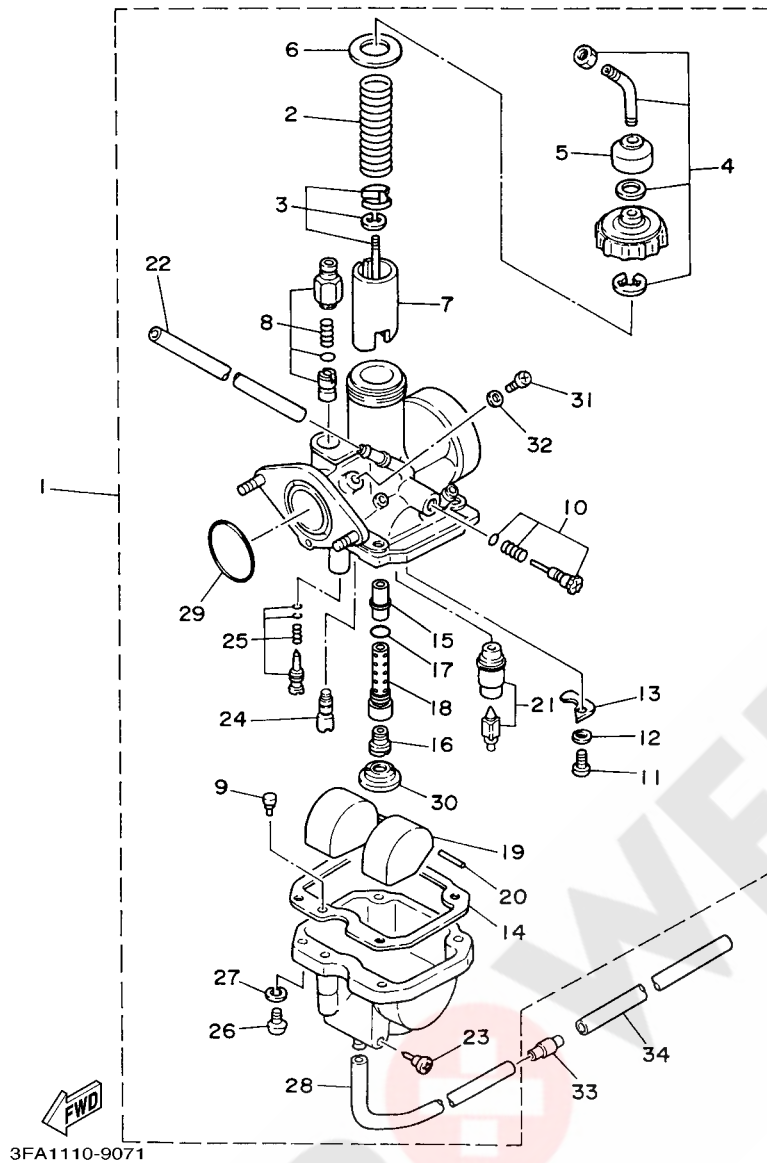

FIG. 7 CARBURETOR

REF. NO.	PART NO.	DESCRIPTION	EUR	JPN	REMARKS
1	5VJ-14101-10	CARBURETOR ASSY 1	1	1	
2	21V-14131-00	.SPRING, THROTTLE VALVE	1	1	
3	3FA-1490J-10	.NEEDLE SET	1	1	
4	10X-14106-00	.CABLE ADJUST SCREW SET	1	1	
5	3X3-14169-00	.CAP	1	1	
6	4U5-14126-00	.GASKET	1	1	
7	3FA-14112-25	.VALVE, THROTTLE 1	1	1	
8	5VJ-1410A-00	.STARTER SET	1	1	
9	18M-14144-09	.JET, STARTER	1	1	
10	18G-14103-00	.THROTTLE SCREW SET	1	1	
11	97802-03008	.SCREW, PAN HEAD	1	1	
12	92902-03100	.WASHER	1	1	
13	21V-14146-00	.PLATE	1	1	
14	24W-14184-00	.GASKET, FLOAT CHAMBER	1	1	
15	21V-1414M-31	.NOZZLE, MAIN	1	1	
16	620-1423A-66	.JET, MAIN (#77.5)	1	1	
17	583-14561-00	.O-RING	1	1	
18	3FA-14148-00	.PIPE	1	1	
19	21V-14185-00	.FLOAT	1	1	
20	127-14186-00	.PIN, FLOAT	1	1	
21	5HH-14190-18	.NEEDLE VALVE ASSY	1	1	
22	3FA-14197-00	.PIPE	1	1	
23	12R-14191-00	.PLUG, DRAIN	1	1	
24	1NT-14142-12	.JET, PILOT (# 12.5)	1	1	
25	21V-14105-00	.PILOT SCREW SET	1	1	
26	98502-04014	.SCREW, PAN HEAD	4	4	
27	92902-04100	.WASHER, SPRING	4	4	

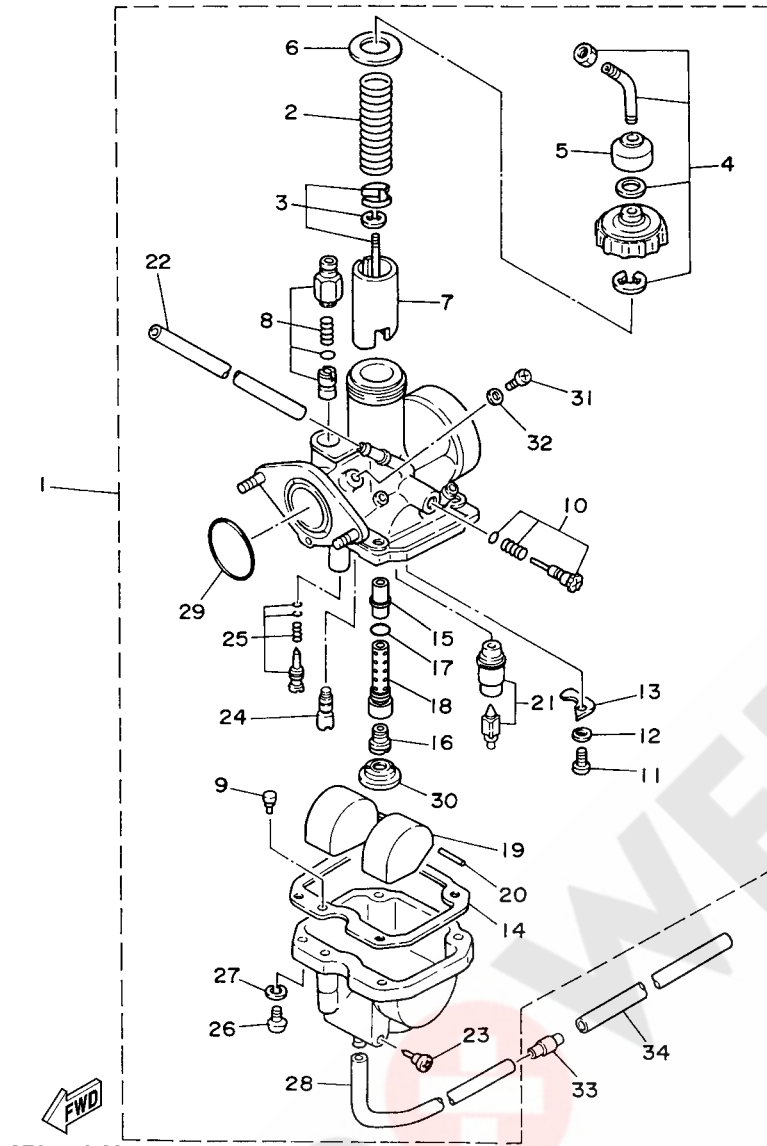
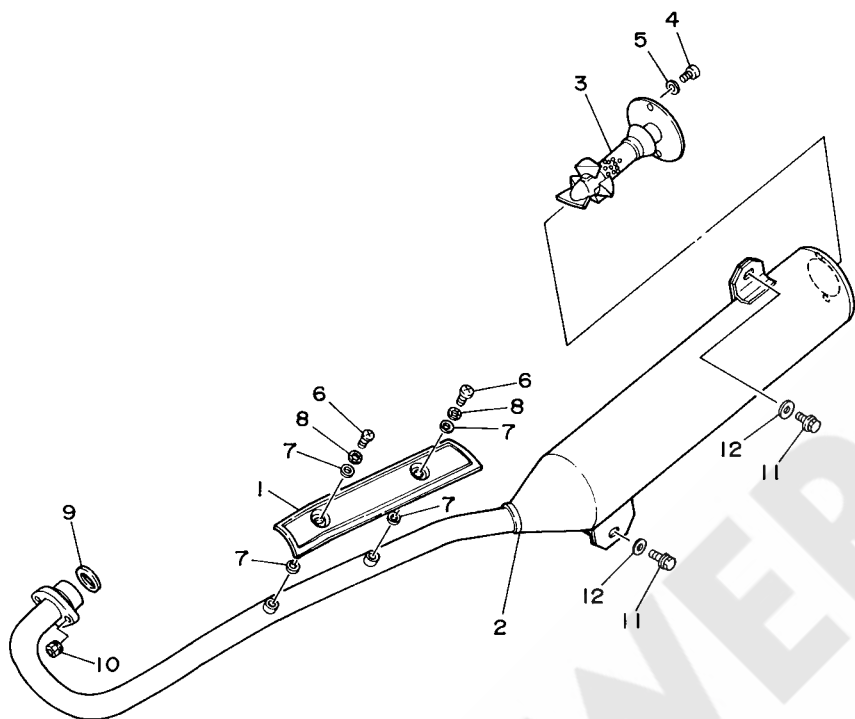

FIG. 7 CARBURETOR

REF. NO.	PART NO.	DESCRIPTION	EUR	JPN	REMARKS
28	29U-14197-00	.PIPE	1	1	
29	24W-14147-00	.O-RING	1	1	
30	5V7-14153-00	.PLATE,BAFFLE	1	1	
31	92502-06008	.SCREW, PAN HEAD	1	1	
32	59V-14962-00	.WASHER	1	1	
33	24W-14193-00	PIPE	1	1	
34	91A20-07010	TUBE, FLEXIBLE VINYL	1	1	

FIG. 8 EXHAUST

REF. NO.	PART NO.	DESCRIPTION	EUR	JPN	REMARKS
1	3FA-14628-00	PROTECTOR, EXHAUST PIPE	1	1	
2	3FA-14711-00	MUFFLER 1	1	1	
3	55X-14752-00	PIPE, OUTLET	1	1	
4	98502-06010	SCREW, PAN HEAD	2	2	
5	92902-06600	WASHER, PLATE	2	2	
6	98902-06010	SCREW, BIND	2	2	
7	4BD-14766-00	WASHER, PROTECTOR	4	4	
8	90206-06090	WASHER, WAVE	2	2	
9	3DM-14613-00	GASKET, EXHAUST PIPE	1	1	
10	95702-06500	NUT, FLANGE	2	2	
11	95812-08016	BOLT, FLANGE	2	2	
12	90201-08048	WASHER, PLATE	2	2	



3FA1110-9080

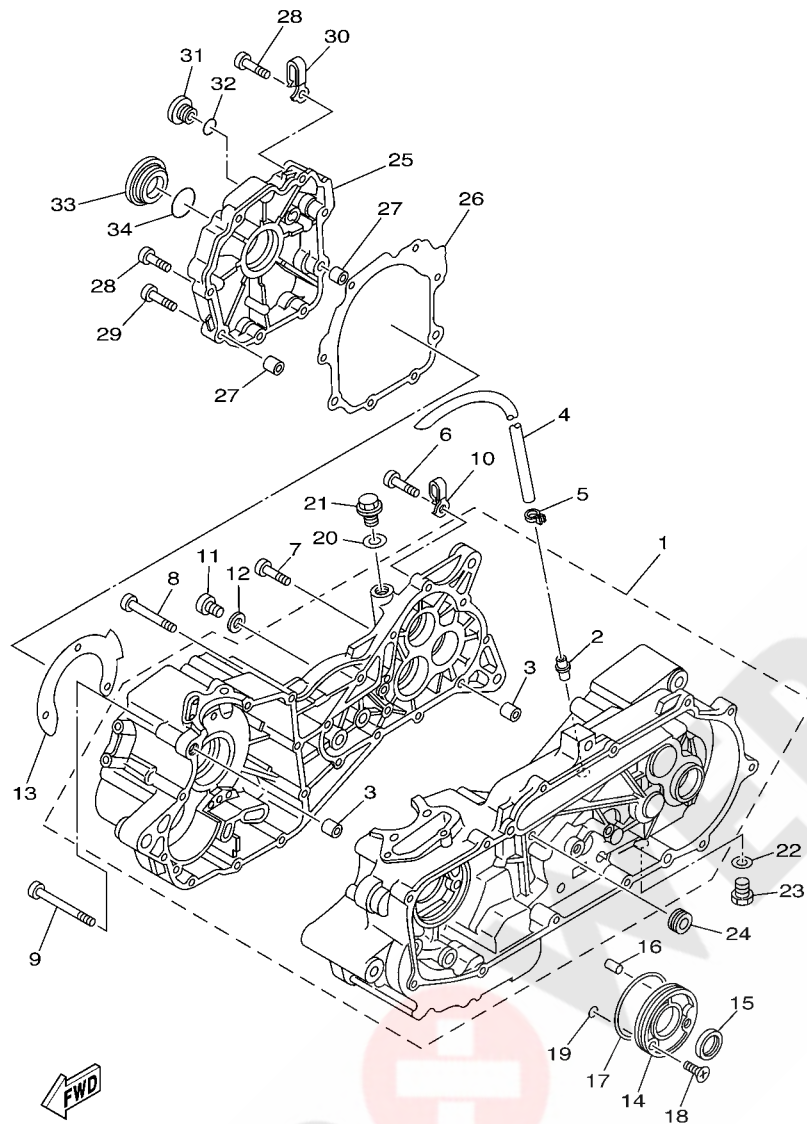

5VJ1100-3090

FIG. 9 CRANKCASE

REF. NO.	PART NO.	DESCRIPTION	EUR	JPN	REMARKS
1	3FA-15100-00	CRANKCASE ASSY	1	1	
2	59V-11167-00	.PIPE, BREATHER 2	1	1	
3	99530-12016	.PIN, DOWEL	2	2	
4	90445-121F6	HOSE (L700)	1	1	
5	90467-13064	CLIP	1	1	
6	98502-06030	SCREW, PAN HEAD	9	9	
7	98502-06040	SCREW, PAN HEAD	1	1	
8	98502-06060	SCREW, PAN HEAD	9	9	
9	98502-06070	SCREW, PAN HEAD	1	1	
10	90465-08127	CLAMP	1	1	
11	98502-08012	SCREW, PAN HEAD	1	1	
12	90201-08087	WASHER, PLATE	1	1	
13	3FA-15462-10	GASKET, CRANKCASE COVER 3	1	1	
14	50M-15418-00	COVER, CHAIN CASE	1	1	
15	93102-22294	OIL SEAL	1	1	
16	93605-18078	PIN, DOWEL	1	1	
17	93210-704A7	O-RING	1	1	
18	98702-06016	SCREW, FLAT HEAD	2	2	
19	93210-06564	O-RING	2	2	
20	214-11198-01	GASKET	1	1	
21	90340-14132	PLUG, STRAIGHT SCREW	1	1	
22	90430-14043	GASKET	1	1	
23	90340-14036	PLUG, STRAIGHT SCREW	1	1	
24	90480-13018	GROMMET	1	1	
25	3FA-15787-00	ADAPTOR	1	1	
26	3FA-15461-10	GASKET, CRANKCASE COVER 2	1	1	
27	99530-10114	PIN, DOWEL	2	2	



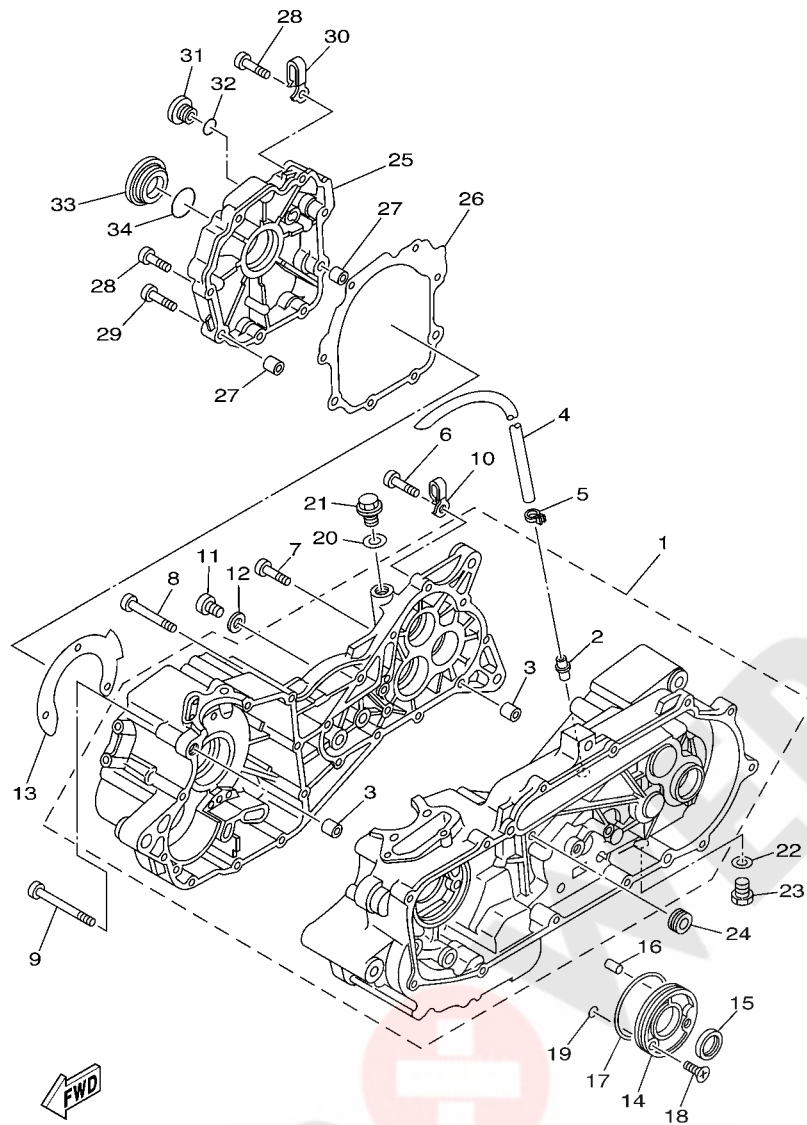

5VJ1100-3090

FIG. 9 CRANKCASE

REF. NO.	PART NO.	DESCRIPTION	EUR	JPN	REMARKS
28	98502-06030	SCREW, PAN HEAD	6	6	
29	98502-06040	SCREW, PAN HEAD	2	2	
30	90465-08125	CLAMP	2	2	
31	90340-14117	PLUG, STRAIGHT SCREW	1	1	
32	93210-14369	O-RING	1	1	
33	90340-36078	PLUG, STRAIGHT SCREW	1	1	
34	93210-357A3	O-RING	1	1	

FIG. 10 CRANKCASE COVER 1

REF. NO.	PART NO.	DESCRIPTION	EUR	JPN			REMARKS
1	3FA-15411-00	COVER, CRANKCASE 1	1	1			
2	3FA-15451-11	GASKET, CRANKCASE COVER 1	1	1			
3	3FA-15467-00	GASKET	1	1			
4	99530-10114	PIN, DOWEL	2	2			
5	98502-06030	SCREW, PAN HEAD	12	12			
6	98502-06090	SCREW, PAN HEAD	1	1			
7	98502-06008	SCREW, PAN HEAD	1	1			
8	90201-06630	WASHER, PLATE	1	1			
9	3FA-15362-00	PLUG, OIL LEVEL	1	1			
10	93210-19123	O-RING	1	1			
11	3FA-15471-00	DUCT, AIR	1	1			
12	3FA-15472-00	SEAL, AIR DUCT	1	1			
13	98502-06030	SCREW, PAN HEAD	5	5			
14	98502-06045	SCREW, PAN HEAD	1	1			
15	3FA-15475-00	DUCT, AIR	1	1			
16	90450-54008	HOSE CLAMP ASSY	2	2			
17	3FA-15477-00	DUCT, AIR	1	1			

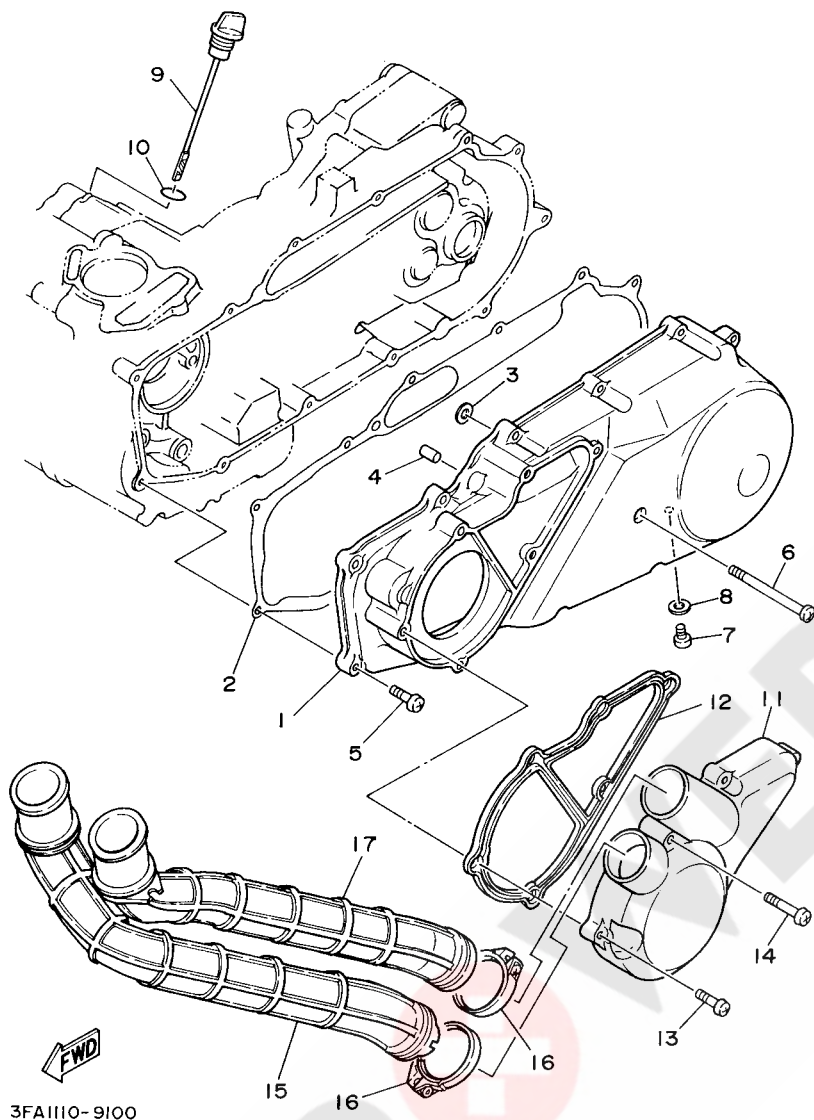
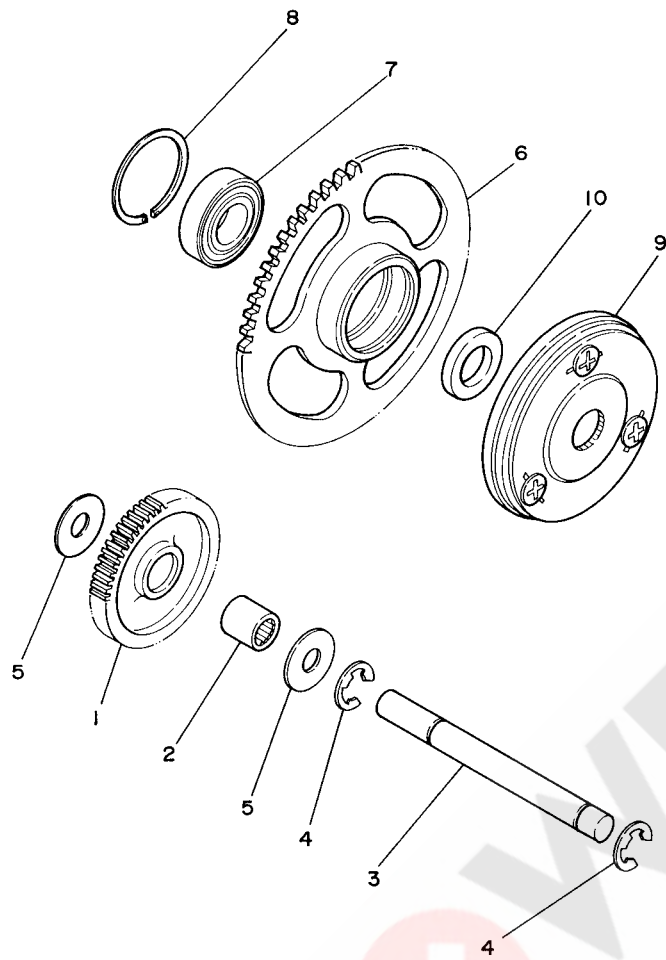

FIG. 11 STARTER CLUTCH



  
3FA1110-9110

REF. NO.	PART NO.	DESCRIPTION	EUR	JPN			REMARKS
1	50M-15512-00	GEAR, IDLER 1 (55T/14T)	1	1			
2	93315-11040	BEARING	1	1			
3	3FA-15521-00	SHAFT 1	1	1			
4	99001-09600	CIRCLIP	2	2			
5	90201-10061	WASHER, PLATE	2	2			
6	50M-15524-00	WHEEL, STARTER (55T)	1	1			
7	93306-00307	BEARING	1	1			
8	99009-35700	CIRCLIP	1	1			
9	50M-15570-02	STARTER CLUTCH ASSY	1	1			
10	90201-163F8	WASHER, PLATE	1	1			

FIG. 12 CLUTCH

REF. NO.	PART NO.	DESCRIPTION	EUR	JPN	REMARKS
1	3FA-16111-00	GEAR, PRIMARY DRIVE (14T)	1	1	
2	99009-22400	CIRCLIP	1	1	
3	93306-00433	BEARING	1	1	
4	93102-22335	OIL SEAL	1	1	
5	90201-06412	WASHER, PLATE	1	1	
6	98502-06010	SCREW, PAN HEAD	1	1	
7	3FA-16620-00	CLUTCH CARRIER ASSY	1	1	
8	14T-16626-00	.SPRING, CLUTCH WEIGHT 1	3	3	
9	90170-36279	NUT	1	1	
10	1C5-16611-01	CLUTCH HOUSING COMP.	1	1	
11	90179-14469	NUT	1	1	
12	93399-99918	BEARING	1	1	
13	50M-15381-00	PLATE, BEARING COVER	1	1	
14	98502-06010	SCREW, PAN HEAD	1	1	
15	3FA-17620-01	PRIMARY SLIDING SHEAVE COMP.	1	1	
16	93101-21170	OIL SEAL	2	2	
17	50M-17632-00	WEIGHT	6	6	
18	50W-17623-00	CAM	1	1	
19	4CW-17653-00	SLIDER	3	3	
20	93210-97690	O-RING	1	1	
21	50M-17630-00	PRIMARY SHEAVE CAP COMP.	1	1	
22	98980-04012	SCREW, BIND	3	3	
23	90214-04038	WASHER, CLAW	3	3	
24	50M-1763E-01	PLATE	1	1	
25	90387-161V0	COLLAR	1	1	
26	3FA-17641-00	V-BELT	1	1	
27	3FA-17611-01	SHEAVE, PRIMARY FIXED	1	1	

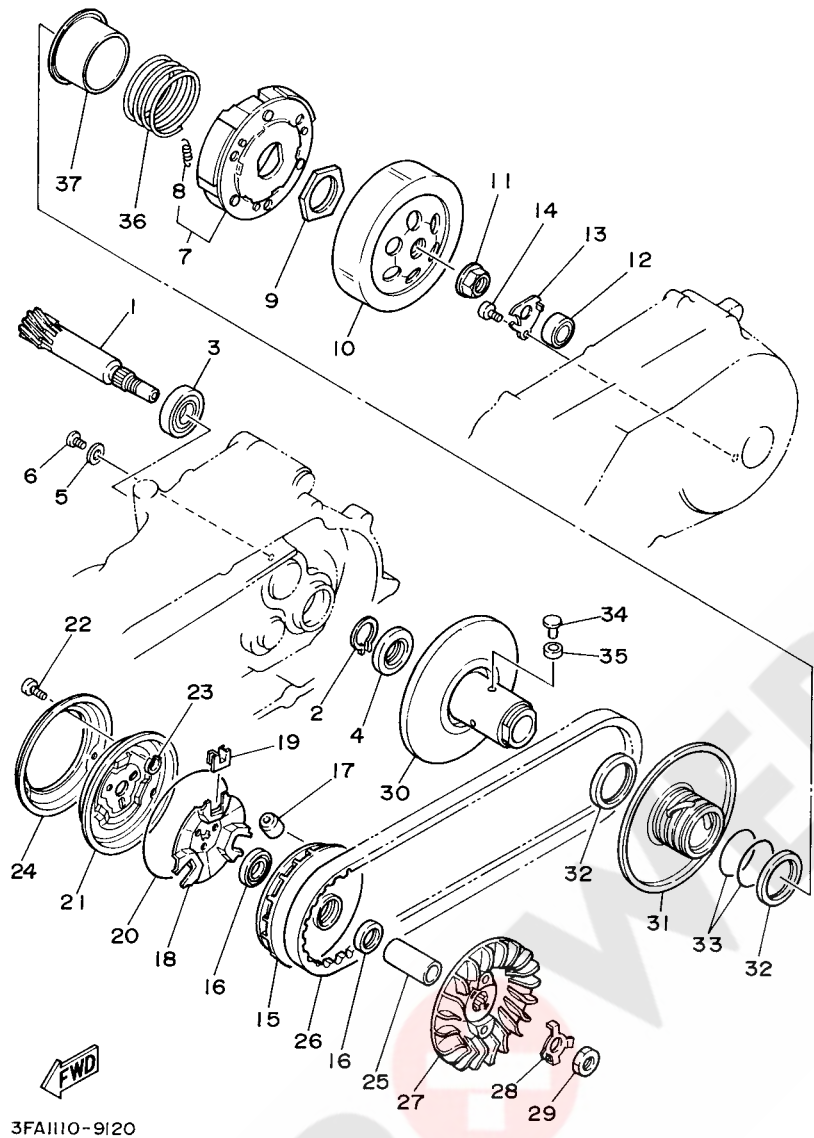

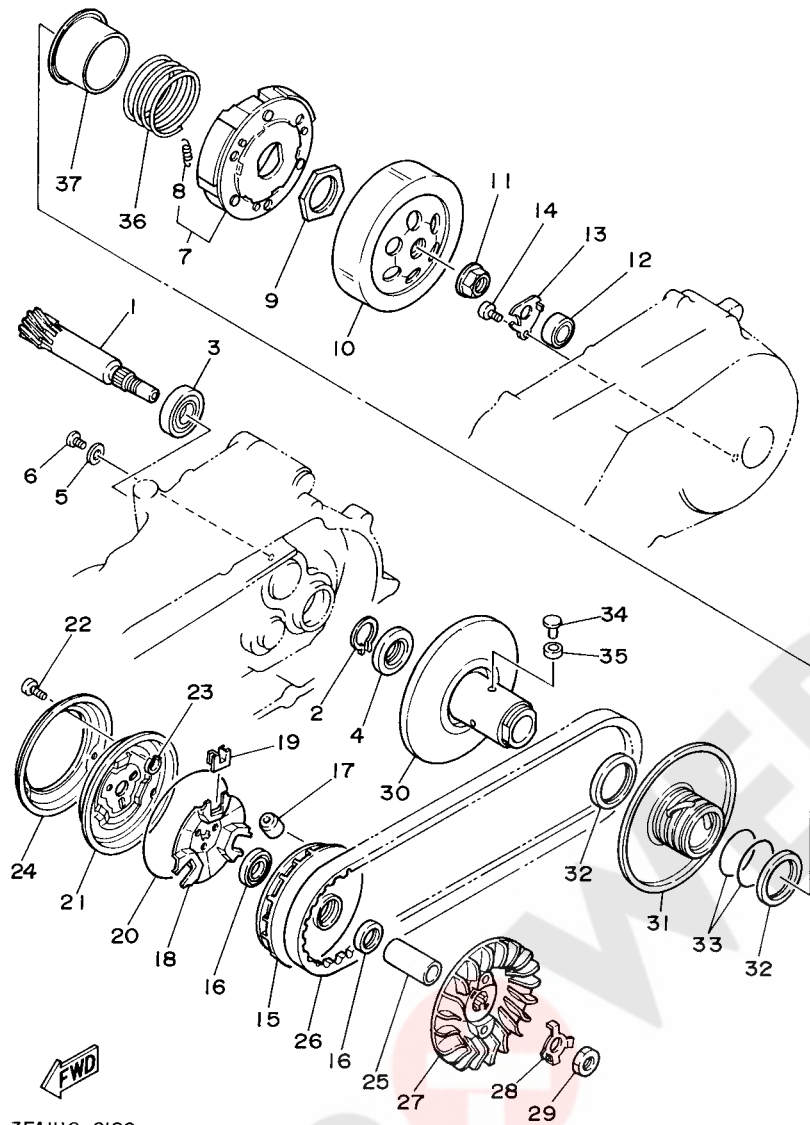

FIG. 12 CLUTCH

REF. NO.	PART NO.	DESCRIPTION	EUR	JPN			REMARKS
28	90215-14236	WASHER, LOCK	1	1			
29	90170-12011	NUT	1	1			
30	3FA-17660-02	SECONDARY FIXED SHEAVE COMP.	1	1			
31	3FA-17670-00	SECONDARY SLIDING SHEAVE	1	1			
32	93104-41119	OIL SEAL	2	2			
33	93210-43713	O-RING	2	2			
34	50W-17664-00	PIN, GUIDE	3	3			
35	50W-17674-00	COLLAR, GUIDE	3	3			
36	90501-505F1	SPRING, COMPRESSION	1	1			
37	3FA-17684-00	SEAT, SECONDARY SPRING	1	1			

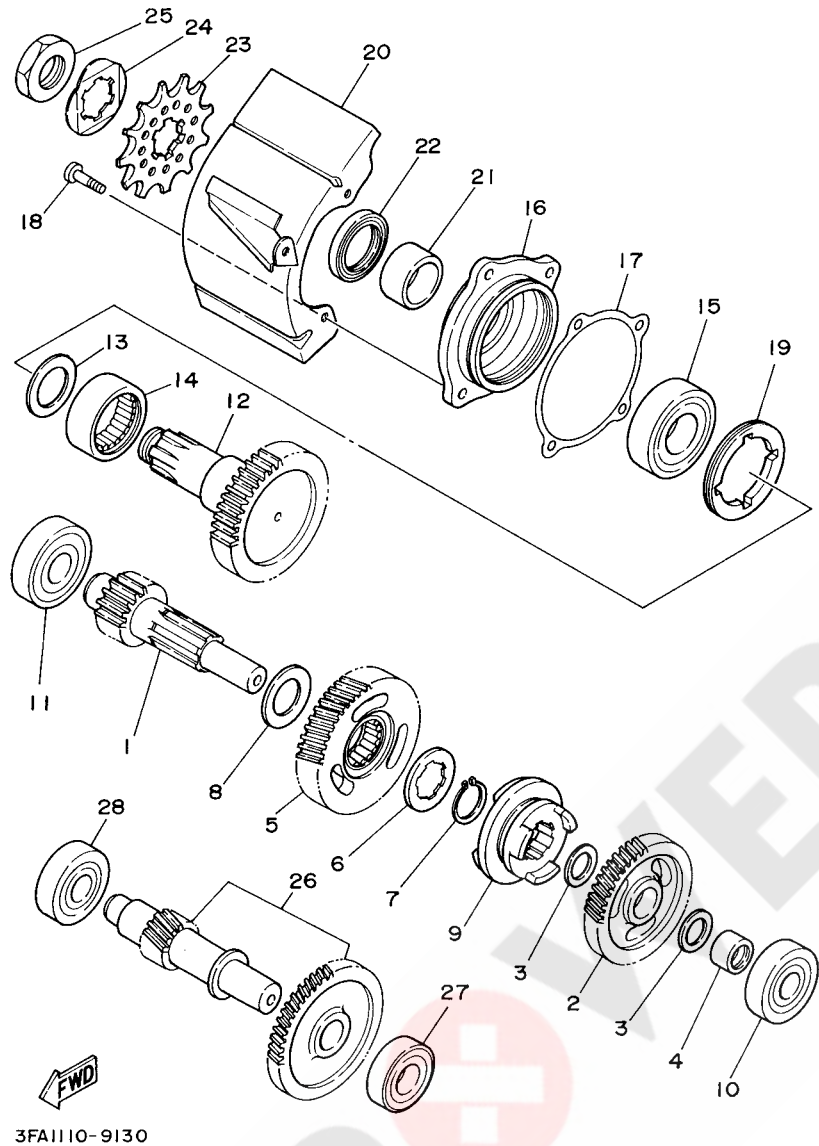

FIG. 13 TRANSMISSION

REF. NO.	PART NO.	DESCRIPTION	EUR	JPN	REMARKS
1	3FA-17411-00	AXLE, MAIN (17T)	1	1	
2	3FA-16151-00	GEAR, PRIMARY DRIVEN (43T)	1	1	
3	90201-15700	WASHER, PLATE	2	2	
4	90560-15348	SPACER	1	1	
5	3FA-17270-00	REDUCTION GEAR ASSY (49T)	1	1	
6	90215-22276	WASHER, LOCK	1	1	
7	93410-22039	CIRCLIP	1	1	
8	90201-221M8	WASHER, PLATE	1	1	
9	3FA-17285-00	CLUTCH, DOG	1	1	
10	93306-20201	BEARING	1	1	
11	93306-20401	BEARING	1	1	
12	3FA-17421-00	AXLE, DRIVE (40T)	1	1	
13	90201-252A4	WASHER, PLATE	1	1	
14	93311-43048	BEARING	1	1	
15	93306-20532	BEARING	1	1	
16	3FA-17551-00	HOUSING, BEARING	1	1	
17	3FA-17519-10	GASKET, HOUSING CAP	1	1	
18	91312-06020	BOLT	4	4	
19	90179-55464	NUT	1	1	
20	3FA-17471-01	PLATE, COVER	1	1	
21	90387-251W4	COLLAR	1	1	
22	93102-30243	OIL SEAL	1	1	
23	93834-12016	SPROCKET,DRIVE 12T(38V1746120)	1	1	
24	90215-21239	WASHER, LOCK	1	1	
25	90179-20255	NUT	1	1	
26	3FA-17430-00	COUNTER AXLE ASSY (15T)	1	1	
27	93306-20301	BEARING	1	1	

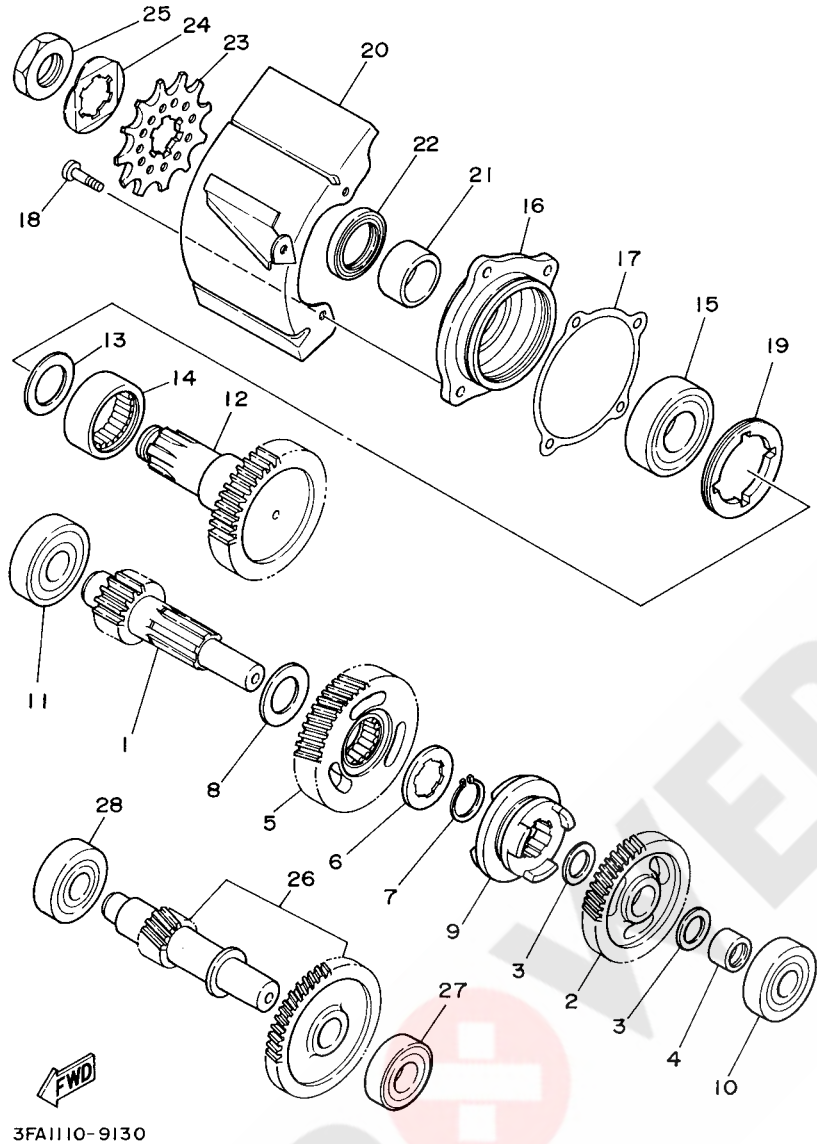

FIG. 13 TRANSMISSION

REF. NO.	PART NO.	DESCRIPTION	EUR	JPN	REMARKS
28	93306-30201	BEARING	1	1	

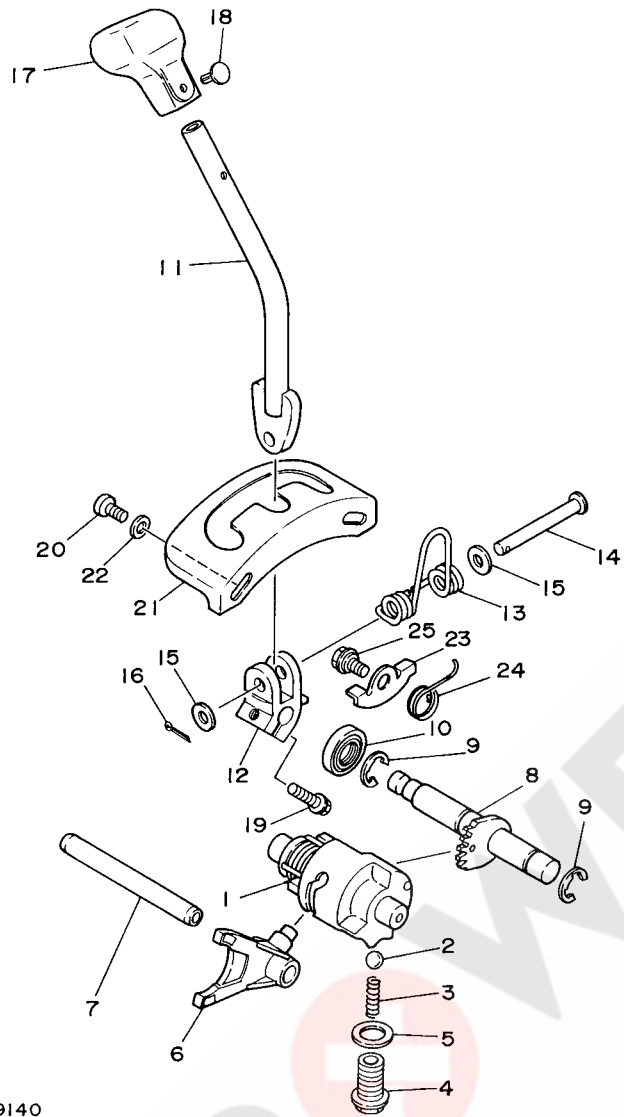
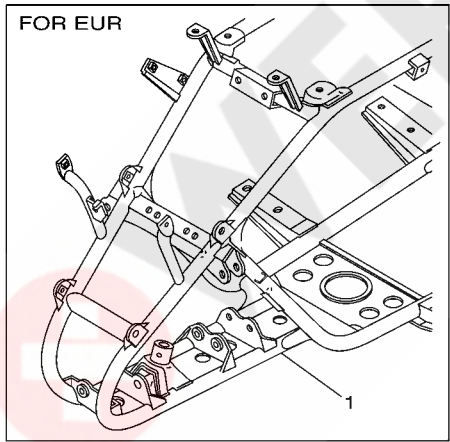
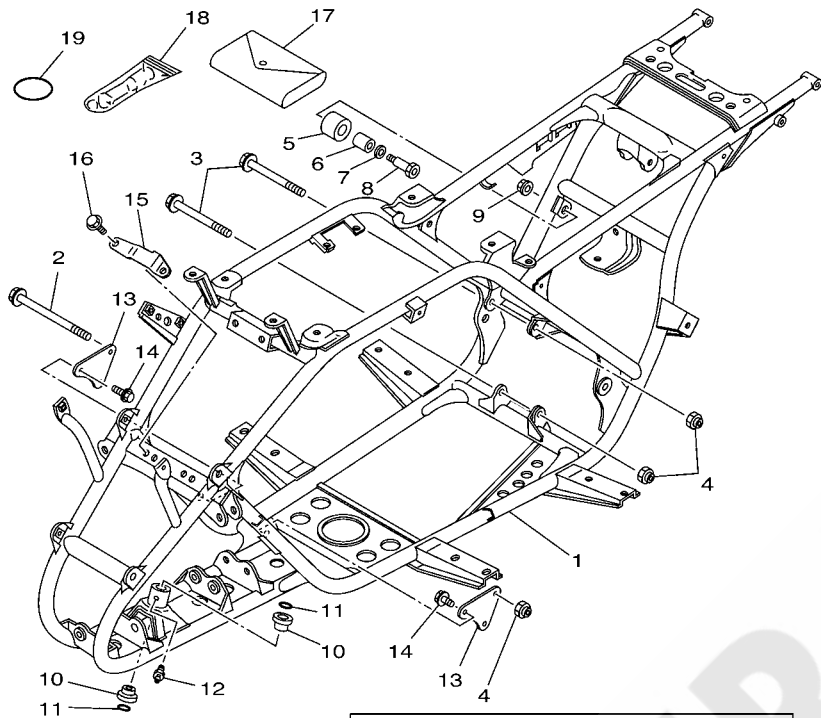

FIG. 14 SHIFT CAM & FORK

REF. NO.	PART NO.	DESCRIPTION	EUR	JPN	REMARKS
1	3FA-18540-00	SHIFT CAM ASSY	1	1	
2	93503-08007	BALL	1	1	
3	90501-10353	SPRING, COMPRESSION	1	1	
4	90105-14003	BOLT, FLANGE	1	1	
5	90430-14194	GASKET	1	1	
6	4GB-18512-00	FORK, SHIFT 2	1	1	
7	1HX-18535-00	BAR, SHIFT FORK GUIDE 2	1	1	
8	3FA-18101-01	SHIFT SHAFT ASSY	1	1	
9	99001-12600	CIRCLIP	2	2	
10	93102-14209	OIL SEAL	1	1	
11	3FA-18152-00	LEVER, SHIFT 4	1	1	
12	3FA-18164-00	BOSS, SHIFT	1	1	
13	90508-29760	SPRING, TORSION	1	1	
14	91701-08058	PIN	1	1	
15	92902-08600	WASHER, PLATE	2	2	
16	91401-25015	PIN, COTTER	1	1	
17	3FA-18174-00	KNOB, SHIFT LEVER	1	1	
18	90269-05055	RIVET	1	1	
19	95822-06025	BOLT, FLANGE	1	1	
20	91312-06016	BOLT	2	2	
21	3FA-18128-00	BRACKET	1	1	
22	92902-06600	WASHER, PLATE	2	2	
23	3FA-18191-00	LEVER	1	1	
24	90508-12761	SPRING, TORSION	1	1	
25	90109-06189	BOLT	1	1	

FWD  
3FA1110-9140





  
 1C51100-C150

FIG. 15 FRAME

REF. NO.	PART NO.	DESCRIPTION	EUR	JPN				REMARKS
1	1C5-21110-30	FRAME COMP.	1					
	1C5-21110-20	FRAME COMP.		1				
2	90105-10183	BOLT, FLANGE	1	1				
3	90105-10277	BOLT, FLANGE	2	2				
4	90185-10022	NUT, SELF-LOCKING	3	3				
5	10V-22178-00	TENSIONER	1	1				
6	4V4-22184-00	BUSH	1	1				
7	90201-13409	WASHER, PLATE	1	1				
8	90109-08705	BOLT	1	1				
9	90185-08016	NUT, SELF-LOCKING	1	1				
10	90381-15040	BUSH, SOLID	2	2				
11	93210-15414	O-RING	2	2				
12	93700-06004	NIPPLE, GREASE	1	1				
13	3FA-21315-00	STAY, ENGINE 2	2	2				
14	95812-08016	BOLT, FLANGE	4	4				
15	3FA-2115K-10	BRACKET, 1	1	1				
16	95802-06012	BOLT, FLANGE	2	2				
17	3GB-28100-00	TOOL KIT	1	1				
18	1NV-2811A-01	GAUGE, AIR	1	1				
19	93210-41041	O-RING	1	1				

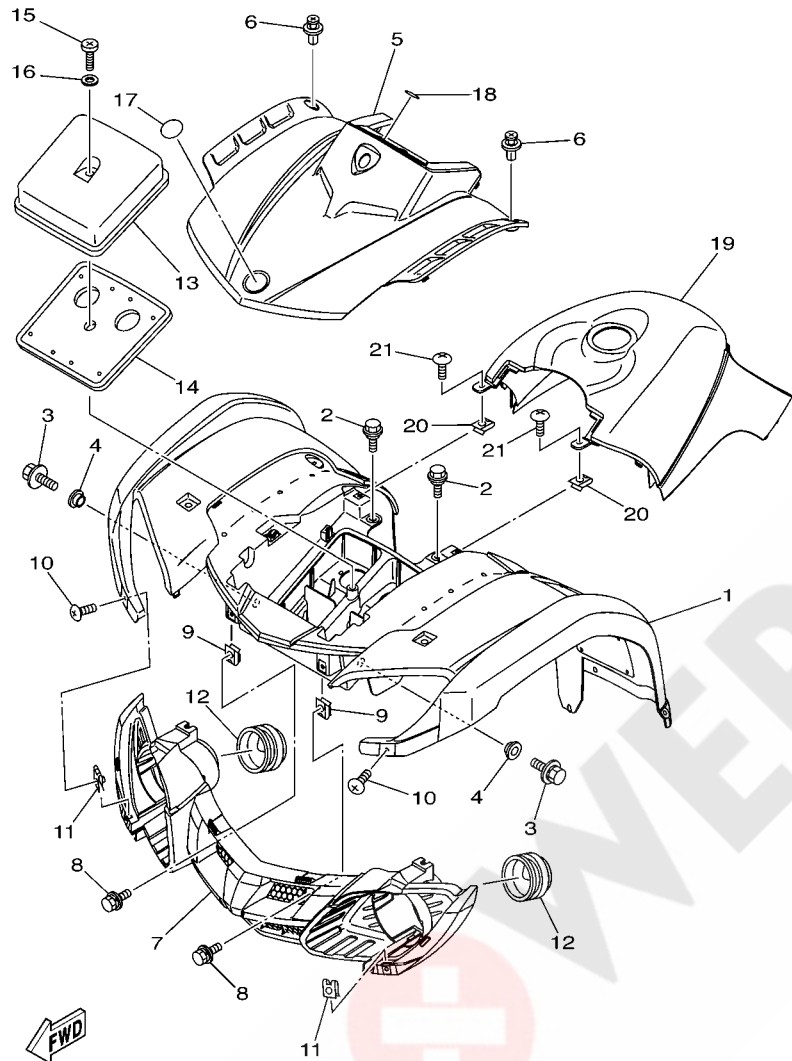

1C51100-C160

FIG. 16 FRONT FENDER

REF. NO.	PART NO.	DESCRIPTION	EUR	JPN	REMARKS
1	1C5-W215B-02	FRONT FENDER COMP. 2	1		UR FOR PDG
	1C5-W215B-12	FRONT FENDER COMP. 2	1		UR FOR DPBSN
	1C5-W215D-02	FRONT FENDER COMP. 2		1	FOR PDG
2	90109-06172	BOLT	2	2	
3	90119-06147	BOLT, WITH WASHER	2	2	
4	90387-06153	COLLAR	2	2	
5	1C5-23391-00	PANEL, FRONT	1	1	
6	90269-07076	RIVET	2	2	
7	1C5-28309-00	GRILLE, FRONT	1	1	
8	90119-06201	BOLT, WITH WASHER	2	2	
9	90183-060A7	NUT, SPRING	2	2	
10	90150-06016	SCREW, ROUND HEAD	2	2	
11	90183-06053	NUT, SPRING	2	2	
12	5GH-28349-00	CAP	2	2	
13	3FA-14422-10	CAP, CLEANER CASE 2	1	1	
14	3FA-14461-00	ELEMENT, AIR CLEANER 2	1	1	
15	98502-05020	SCREW, PAN HEAD	1	1	
16	92902-05600	WASHER, PLATE	1	1	
17	5KM-2175B-00	TUNING FORK MARK	1	1	
18	5GT-2836B-10	TUNING FORK MARK	1	1	
19	1C5-2171A-00	COVER, TOP	1	1	UR FOR PDG
	1C5-2171A-10	COVER, TOP	1		UR FOR DPBSN
20	90183-06053	NUT, SPRING	2	2	
21	90150-06016	SCREW, ROUND HEAD	2	2	

FIG. 17 REAR FENDER

REF. NO.	PART NO.	DESCRIPTION	EUR	JPN		REMARKS
1	1C5-W216B-02	REAR FENDER COMP.2	1			UR FOR PDG
	1C5-W216B-11	REAR FENDER COMP.2	1			UR FOR DPBSN
	1C5-W216D-00	REAR FENDER COMP		1		FOR PDG
2	90119-06152	BOLT, WITH WASHER	5	5		
3	29W-82123-00	SEAT, BATTERY	5	5		
4	1UY-21639-00	DAMPER 2	1	1		

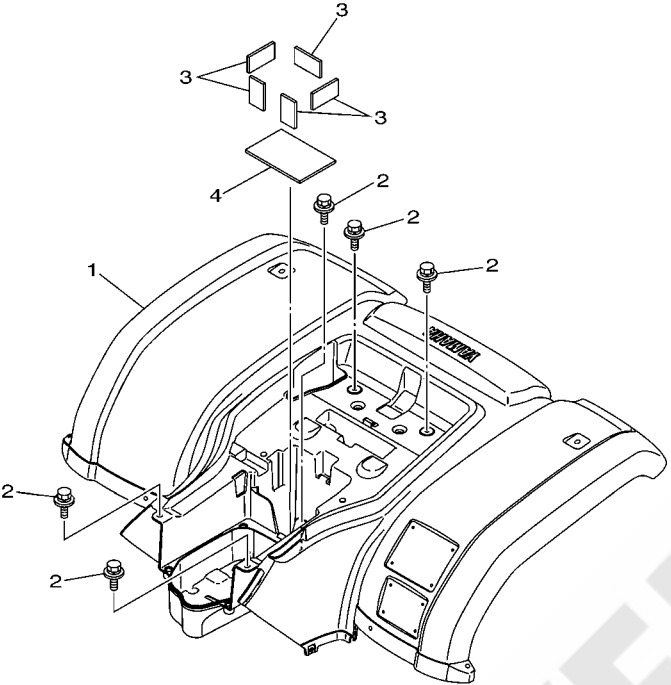

1C51100-C170

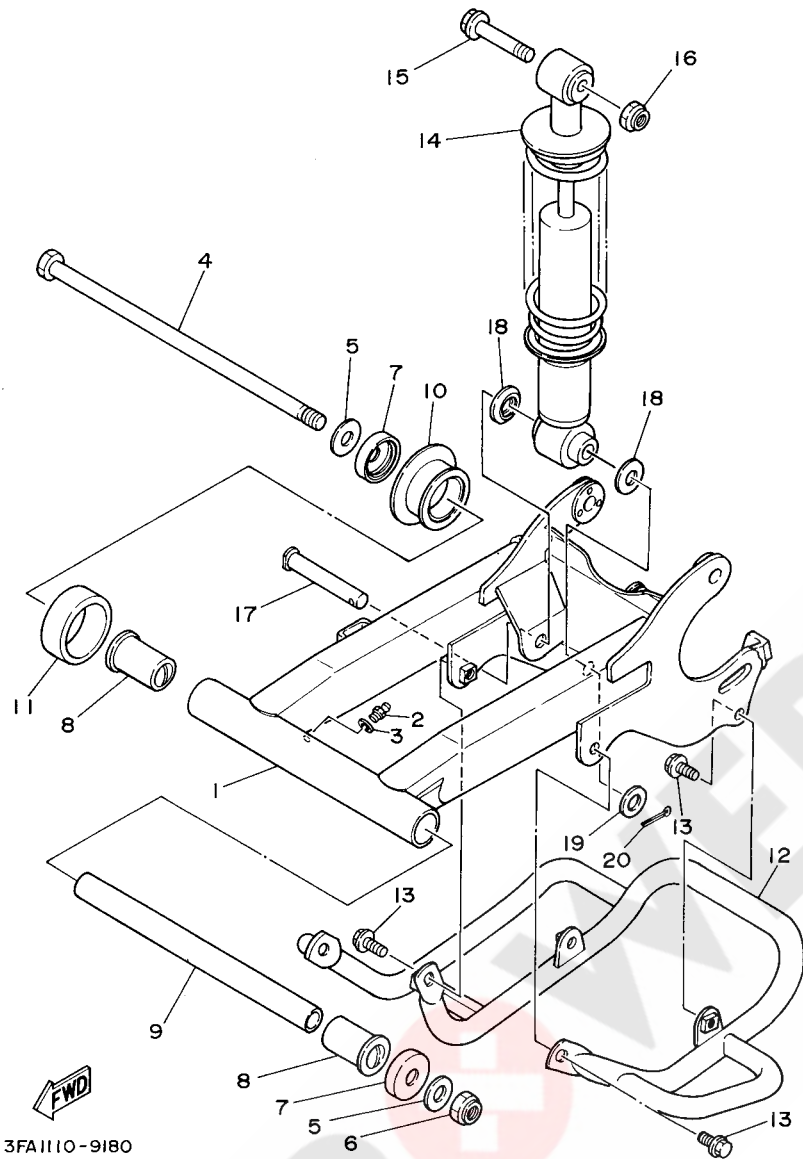

FIG. 18 REAR ARM & SUSPENSION

REF. NO.	PART NO.	DESCRIPTION	EUR	JPN		REMARKS
1	3FA-22110-00-33	REAR ARM COMP.	1	1		YB
2	93700-06004	NIPPLE, GREASE	1	1		
3	92902-06200	WASHER	1	1		
4	2JX-22141-00	SHAFT, PIVOT	1	1		
5	90201-12045	WASHER, PLATE	2	2		
6	90185-12007	NUT, SELF-LOCKING	1	1		
7	401-22128-01	COVER, THRUST 1	2	2		
8	90386-18028	BUSH	2	2		
9	3FA-22126-00	COLLAR, DISTANCE	1	1		
10	2A6-22151-00	SEAL, GUARD	1	1		
11	2A6-22152-00	SEAL, GUARD	1	1		
12	3FA-2219X-00	COVER	1	1		
13	95822-08016	BOLT, FLANGE	5	5		
14	3FA-22210-00-33	SHOCK ABSORBER ASSY, REAR	1	1		YB
15	90105-10131	BOLT, FLANGE	1	1		
16	90185-10022	NUT, SELF-LOCKING	1	1		
17	90240-12092	PIN, CLEVIS	1	1		
18	1W1-22128-00	COVER, THRUST 1	2	2		
19	90201-12047	WASHER, PLATE	1	1		
20	91401-30025	PIN, COTTER	1	1		

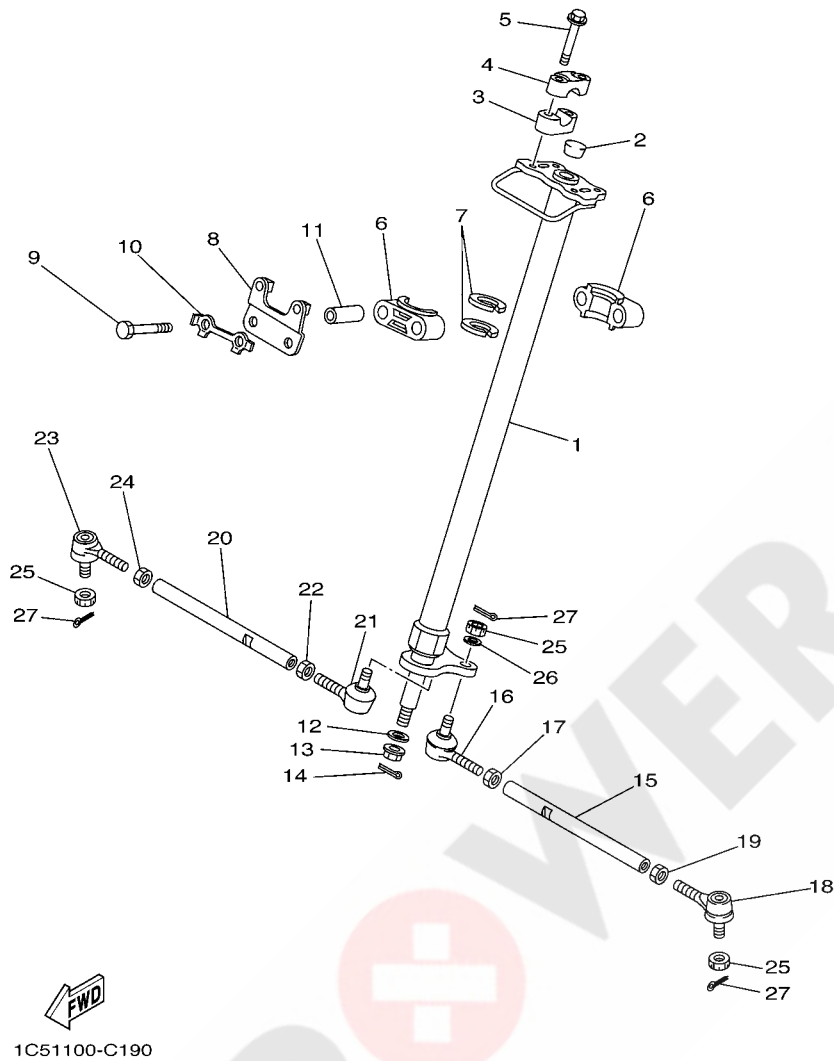
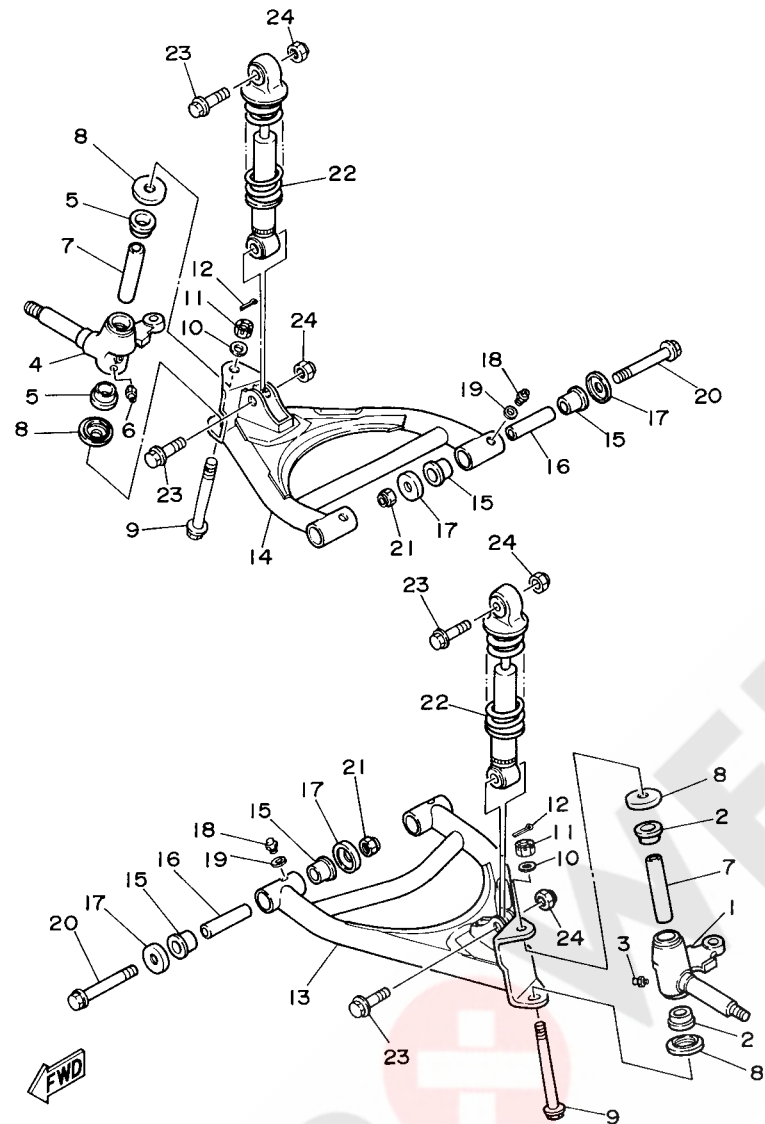

FIG. 19 STEERING

REF. NO.	PART NO.	DESCRIPTION	EUR	JPN	REMARKS
1	1C5-23813-20	COLUMN, STEERING 2	1	1	
2	90336-22056	PLUG, TAPER	1	1	
3	2HR-23442-00	HOLDER, HANDLE LOWER	2	2	
4	8K1-23814-00	HOLDER, HANDLE	2	2	
5	95822-08050	BOLT, FLANGE	4	4	
6	1UY-23812-00	PLANE BEARING, STEERING	2	2	
7	93112-31011	OIL SEAL	2	2	
8	3FA-23868-30	BRACKET, STEERING LOWER	1	1	
9	97022-08060	BOLT	2	2	
10	1UY-23894-01	WASHER, LOCK 1	1	1	
11	90387-090R0	COLLAR	2	2	
12	90201-10036	WASHER, PLATE	1	1	
13	90185-10019	NUT, SELF-LOCKING	1	1	
14	91401-20020	PIN, COTTER	1	1	
15	3FA-23831-10	ROD, TIE	1	1	
16	1UY-23841-01	JOINT, UNIVERSAL 1	1	1	
17	95302-10700	NUT	1	1	
18	1UY-23845-01	JOINT, UNIVERSAL 2	1	1	
19	90170-10010	NUT	1	1	(L.H. THREAD)
20	3FA-23831-10	ROD, TIE	1	1	
21	1UY-23841-01	JOINT, UNIVERSAL 1	1	1	
22	95302-10700	NUT	1	1	
23	1UY-23845-01	JOINT, UNIVERSAL 2	1	1	
24	90170-10010	NUT	1	1	(L.H. THREAD)
25	90171-10001	NUT, CASTLE	4	4	
26	92990-10600	WASHER, PLATE	2	2	
27	91401-20020	PIN, COTTER	4	4	



3FA1110-9190

FIG. 20 FRONT SUSPENSION & WHEEL

REF. NO.	PART NO.	DESCRIPTION	EUR	JPN		REMARKS
1	3FA-23511-01	KNUCKLE, STEERING 1	1	1		
2	90381-17067	BUSH, SOLID	2	2		
3	93700-06004	NIPPLE, GREASE	1	1		
4	3FA-23521-01	KNUCKLE, STEERING 2	1	1		
5	90381-17067	BUSH, SOLID	2	2		
6	93700-06004	NIPPLE, GREASE	1	1		
7	3GB-23448-00	SPACER	2	2		
8	2NL-23517-00	COVER, THRUST 1	4	4		
9	90105-10274	BOLT, FLANGE	2	2		
10	90201-10057	WASHER, PLATE	2	2		
11	90171-10003	NUT, CASTLE	2	2		
12	91401-20020	PIN, COTTER	2	2		
13	3FA-23570-00-33	FRONT LOWER ARM COMP. (LEFT)	1	1		YB
14	3FA-23580-00-33	FRONT LOWER ARM COMP. (RIGHT)	1	1		YB
15	90381-15088	BUSH, SOLID	8	8		
16	90387-101R3	COLLAR	4	4		
17	5YT-23517-00	COVER, THRUST 1	8	8		
18	93700-06004	NIPPLE, GREASE	4	4		
19	92902-06200	WASHER	4	4		
20	90105-10233	BOLT, FLANGE	4	4		
21	90185-10022	NUT, SELF-LOCKING	4	4		
22	3FA-23350-00-33	SHOCK ABSORBER ASSY	2	2		YB
23	90105-10262	BOLT, FLANGE	4	4		
24	90185-10022	NUT, SELF-LOCKING	4	4		

FIG. 21 FUEL TANK

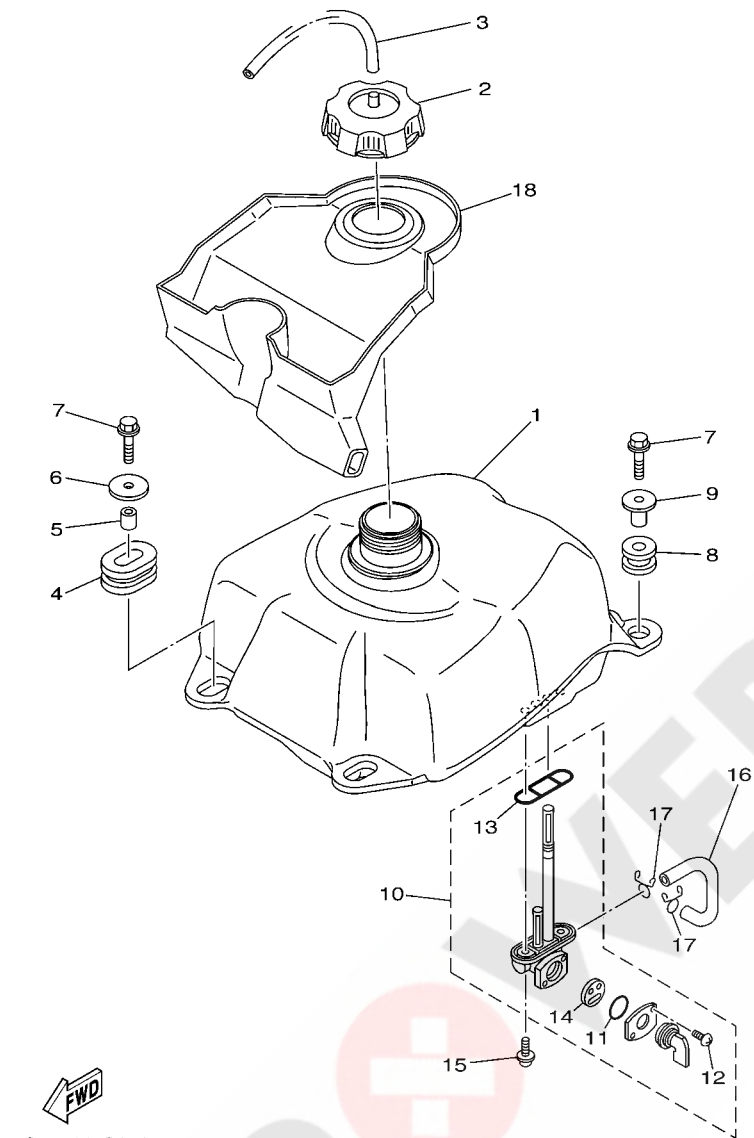

1C51100-C210

REF. NO.	PART NO.	DESCRIPTION	EUR	JPN				REMARKS
1	1C5-24110-00	FUEL TANK COMP.	1	1				
2	2FJ-24610-10	CAP ASSY	1	1				
3	90445-09304	HOSE (L310)	1	1				
4	90480-01400	GROMMET	2	2				
5	90387-07598	COLLAR	2	2				
6	90201-06090	WASHER, PLATE	2	2				
7	95822-06035	BOLT, FLANGE	4	4				
8	90480-18290	GROMMET	2	2				
9	90387-066H4	COLLAR	2	2				
10	55W-24500-02	FUEL COCK ASSY 1	1	1				
11	3AJ-24534-01	.SEAL, COCK	1	1				
12	98507-03008	.SCREW, PAN HEAD	2	2				
13	4X8-24512-00	.O-RING	1	1				
14	3AC-24523-00	.VALVE PACKING	1	1				
15	90149-06108	SCREW	2	2				
16	90445-10456	HOSE (L95)	1	1				
17	90467-09006	CLIP	2	2				
18	1C5-2414H-00	DAMPER, PLATE 1	1	1				

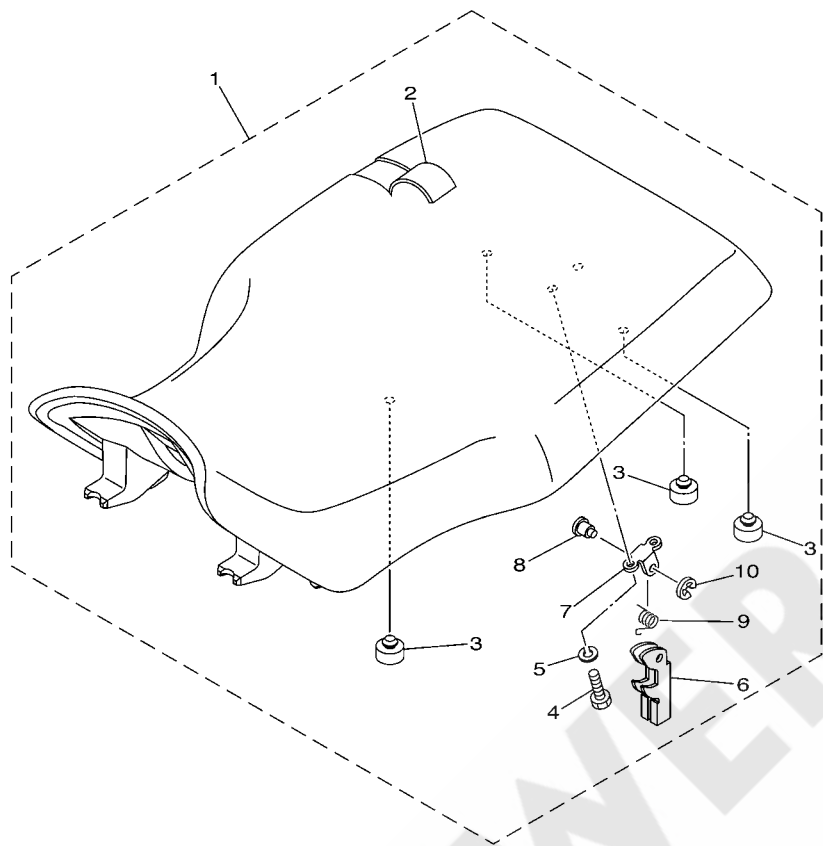

FIG. 22 SEAT

REF. NO.	PART NO.	DESCRIPTION	EUR	JPN	REMARKS
1	1C5-24710-10	SINGLE SEAT ASSY	1	1	
2	1C5-24731-00	.COVER, SEAT	1	1	
3	371-27114-00	.STOPPER, MAIN STAND	3	3	
4	97002-06012	.BOLT	2	2	
5	92902-06100	.WASHER, SPRING	2	2	
6	29U-24776-00	.LEVER, SEAT	1	1	
7	4K0-24775-00	.BRACKET, SEAT LEVER	1	1	
8	4K0-24774-01	.PIN	1	1	
9	90508-20779	.SPRING, TORSION	1	1	
10	99001-04600	.CIRCLIP	1	1	



1C51100-C220



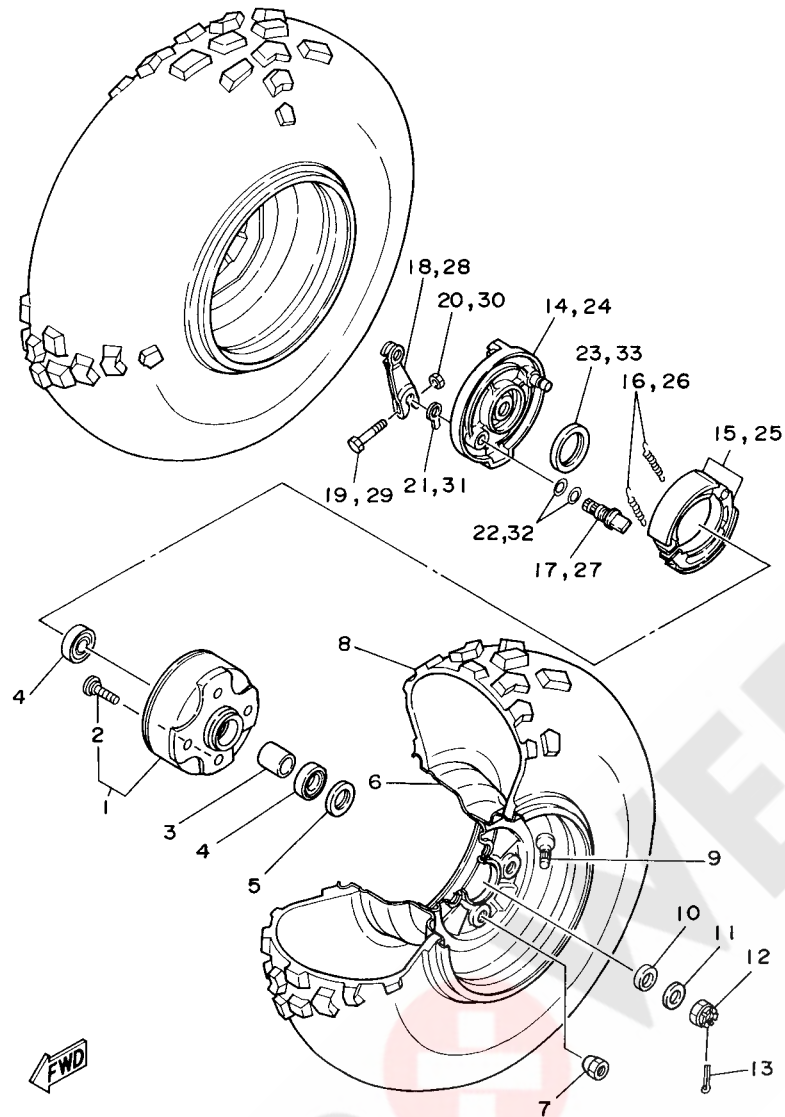

3FAK100-8230

FIG. 23 FRONT WHEEL

REF. NO.	PART NO.	DESCRIPTION	EUR	JPN	REMARKS
1	1C5-25111-00	HUB, FRONT	2	2	
2	90114-10014	.BOLT, SERRATION	4	4	
3	3FA-25117-00	SPACER, BEARING	2	2	
4	93306-00308	BEARING	4	4	
5	93102-23275	OIL SEAL	2	2	
6	3FA-25180-00-98	WHEEL COMP.	2	2	LGB
7	90179-10022	NUT	8	8	
8	94107-08008	TIRE (AT20X7-8*KT536A T/L N)	2	2	DUNLOP
9	93900-00022	VALVE, RIM (TR413)	2	2	TAIHEIYO
10	90387-175R2	COLLAR	2	2	
11	90201-14586	WASHER, PLATE	2	2	
12	90171-14002	NUT, CASTLE	2	2	
13	91401-30025	PIN, COTTER	2	2	
14	3FA-25121-00	PLATE, BRAKE SHOE	1	1	FOR LH
15	4BE-W2536-00	BRAKE SHOE SET	1	1	
16	90506-15260	SPRING, TENSION	2	2	
17	5G3-25351-02	CAMSHAFT	1	1	
18	3FA-25155-00	LEVER, CAMSHAFT 1	1	1	FOR LH
19	90101-06046	BOLT	1	1	
20	95302-06600	NUT	1	1	
21	52H-2513A-00	PLATE, INDICATOR	1	1	
22	93210-12327	O-RING	2	2	
23	93102-40367	OIL SEAL	1	1	
24	3FA-25169-00	PLATE, BRAKE SHOE 2	1	1	FOR RH
25	4BE-W2536-00	BRAKE SHOE SET	1	1	
26	90506-15260	SPRING, TENSION	2	2	
27	5G3-25351-02	CAMSHAFT	1	1	

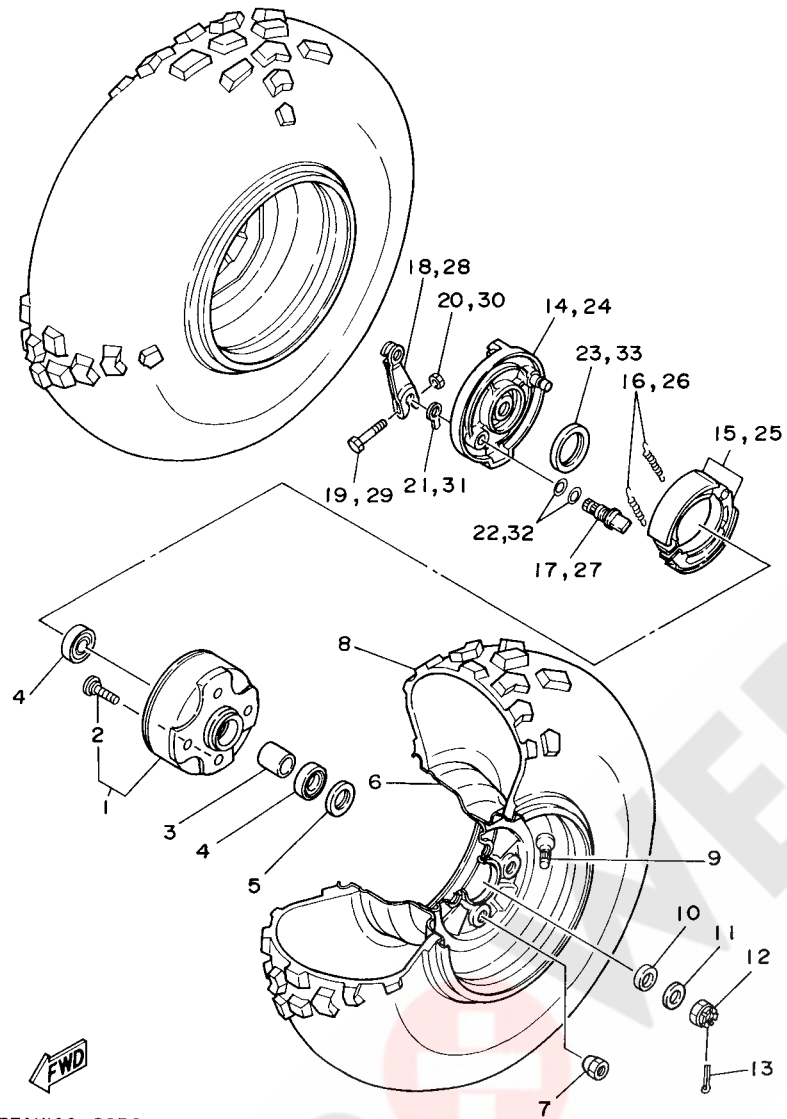

3FAK100-8230

FIG. 23 FRONT WHEEL

REF. NO.	PART NO.	DESCRIPTION	EUR	JPN	REMARKS
28	3FA-25156-00	LEVER, CAMSHAFT 2	1	1	FOR RH
29	90101-06046	BOLT	1	1	
30	95302-06600	NUT	1	1	
31	52H-2513A-00	PLATE, INDICATOR	1	1	
32	93210-12327	O-RING	2	2	
33	93102-40367	OIL SEAL	1	1	

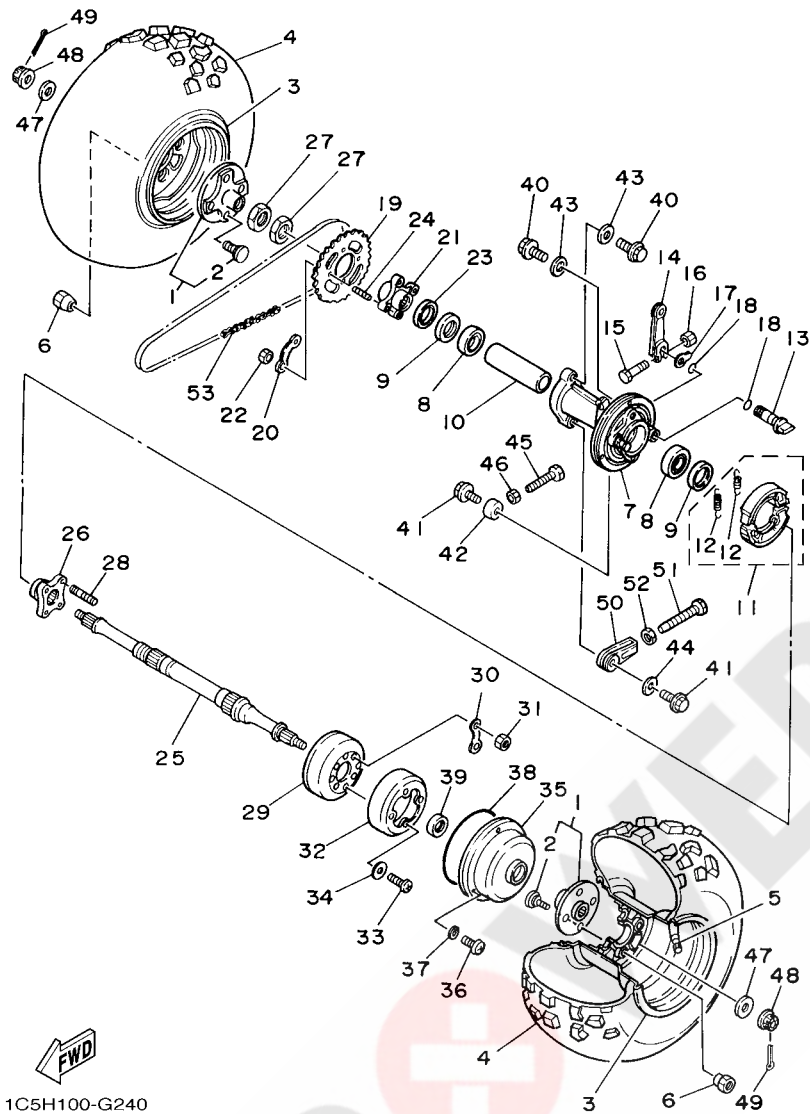

1C5H100-G240

FIG. 24 REAR WHEEL

REF. NO.	PART NO.	DESCRIPTION	EUR	JPN	REMARKS
1	1C5-25383-00	COLLAR, WHEEL	2	2	
2	90114-10014	.BOLT, SERRATION	4	4	
3	3FA-25390-00-98	REAR WHEEL COMP.	2	2	LGB
4	94110-08008	TIRE (AT22X10-8*KT537A T/L N)	2	2	DUNLOP
5	93900-00022	VALVE, RIM (TR413)	2	2	TAIHEIYO
6	90179-10022	NUT	8	8	
7	3FA-25311-00	HUB, REAR	1	1	
8	93306-00710	BEARING	2	2	
9	93102-42260	OIL SEAL	2	2	
10	3FA-25317-00	SPACER, BEARING	1	1	
11	3FA-W253A-00	BRAKE SHOE KIT	1	1	
12	90506-15260	.SPRING, TENSION	2	2	
13	55X-25351-00	CAMSHAFT	1	1	
14	2N3-25155-00	LEVER, CAMSHAFT 1	1	1	
15	90101-06046	BOLT	1	1	
16	95302-06600	NUT	1	1	
17	23F-2533A-00	PLATE, INDICATOR	1	1	
18	93210-14104	O-RING	2	2	
19	3FA-25432-20	SPROCKET, DRIVEN (32T)	1	1	
20	10V-25412-00	WASHER	2	2	
21	3FA-25386-00	COLLAR, SPROCKET AXLE	1	1	
22	90170-10011	NUT	4	4	
23	5V6-25367-00	COVER, HUB DUST	1	1	
24	90116-10042	BOLT, STUD	4	4	
25	3FA-25381-10	AXLE, WHEEL	1	1	
26	3FA-25343-00	BOSS	1	1	
27	90170-33011	NUT	2	2	

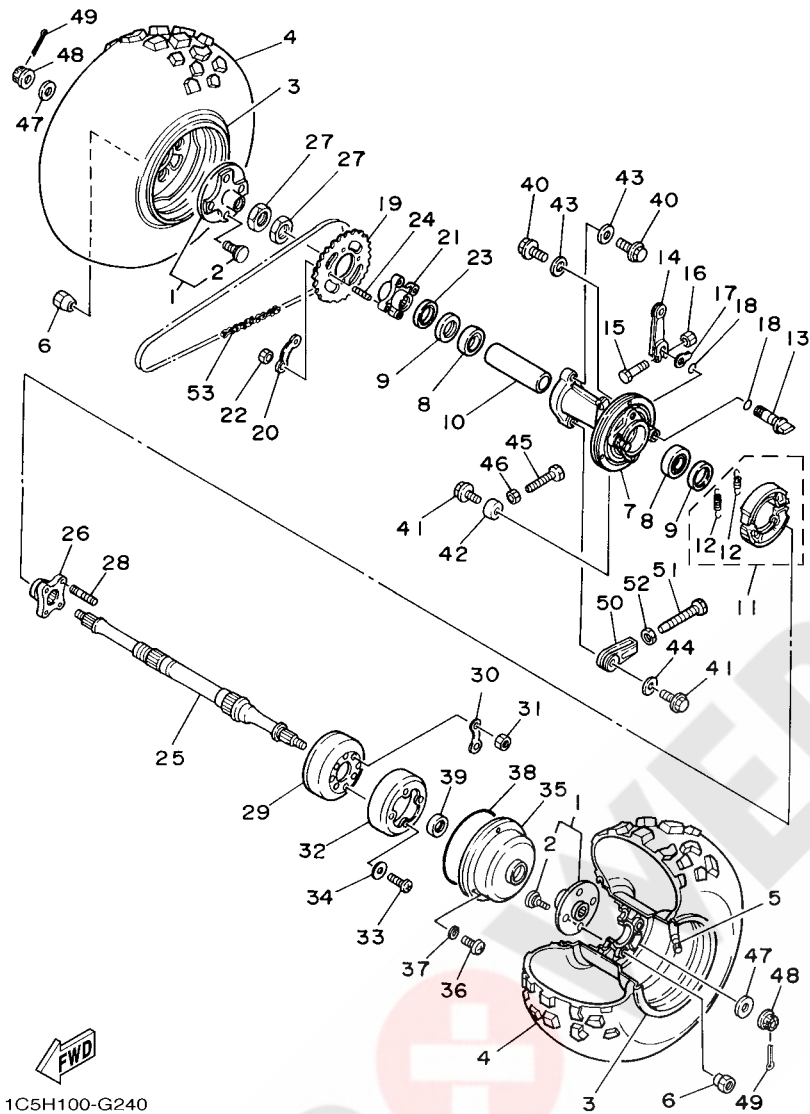

FIG. 24 REAR WHEEL

REF. NO.	PART NO.	DESCRIPTION	EUR	JPN	REMARKS
28	90116-08084	BOLT, STUD	4	4	
29	3FA-2531E-00	DRUM, BRAKE	1	1	
30	390-25412-01	WASHER	2	2	
31	95302-08600	NUT	4	4	
32	3FA-25336-00	RING 2	1	1	
33	98502-05010	SCREW, PAN HEAD	4	4	
34	92902-05600	WASHER, PLATE	4	4	
35	55X-25715-00	COVER 1	1	1	
36	92502-06012	SCREW, PAN HEAD	3	3	
37	92902-06600	WASHER, PLATE	3	3	
38	93211-63688	O-RING	1	1	
39	93102-35349	OIL SEAL	1	1	
40	90105-12060	BOLT, FLANGE	2	2	
41	90105-10280	BOLT, FLANGE	2	2	
42	90387-113W0	COLLAR	1	1	
43	90201-12048	WASHER, PLATE	2	2	
44	90201-10052	WASHER, PLATE	1	1	
45	90101-08056	BOLT	1	1	
46	95302-08600	NUT	1	1	
47	90201-14021	WASHER, PLATE	2	2	
48	90171-14004	NUT, CASTLE	2	2	
49	91401-30030	PIN, COTTER	2	2	
50	1UY-25388-00	PULLER, CHAIN 1	1	1	
51	90101-08647	BOLT	1	1	
52	95302-08600	NUT	1	1	
53	94582-02074	CHAIN (DID520V 74L)	1	1	

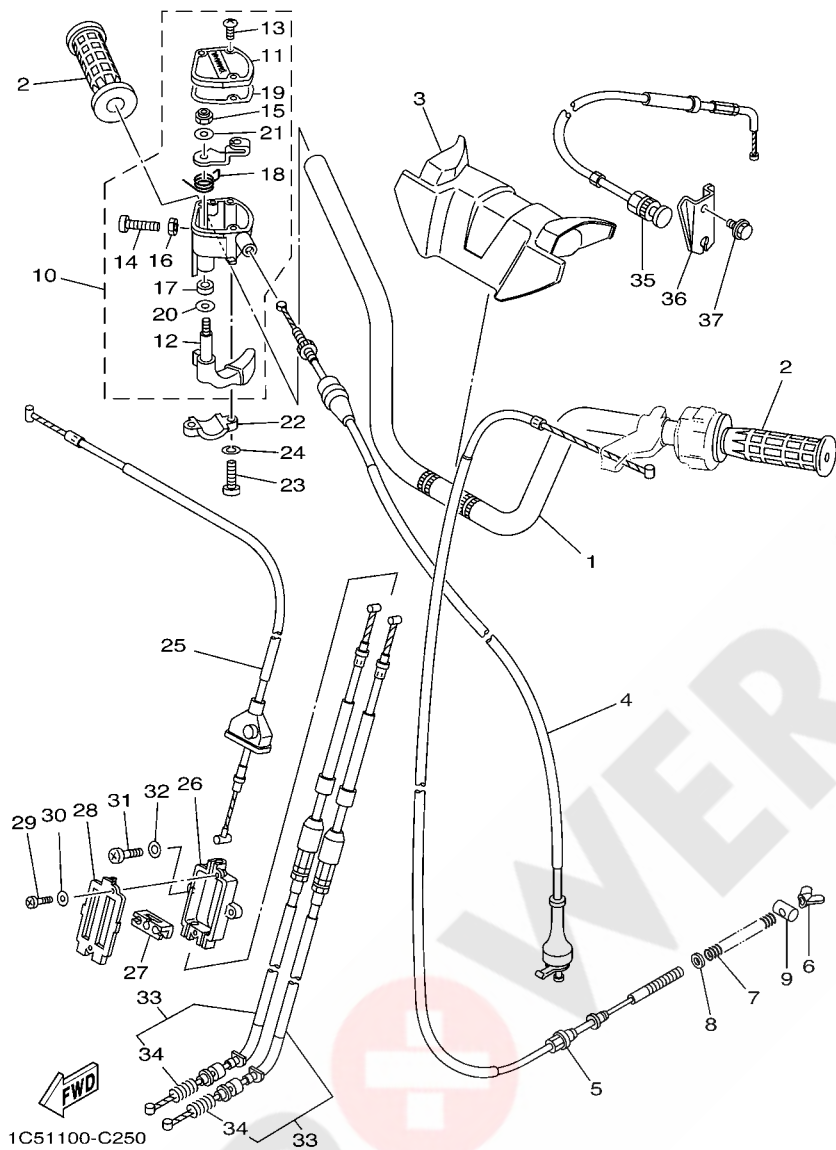

FIG. 25 STEERING HANDLE & CABLE

REF. NO.	PART NO.	DESCRIPTION	EUR	JPN		REMARKS
1	3FA-26111-20	HANDLEBAR	1	1		
2	3GB-26241-00	GRIP	2	2		
3	1C5-26124-00	PROTECTOR, HANDLEBAR	1	1		
4	3FA-26311-10	CABLE, THROTTLE 1	1	1		
5	3FA-26351-03	CABLE, BRAKE	1	1		
6	90175-06013	NUT, WING	1	1		
7	90501-122E1	SPRING, COMPRESSION	1	1		
8	90202-08175	WASHER, PLATE	1	1		
9	90249-12008	PIN	1	1		
10	4KB-26250-10	THROTTLE LEVER ASSY	1	1		
11	4KB-2628F-10	.CAP, GEAR	1	1		
12	1NV-2625G-01	.LEVER, THROTTLE	1	1		
13	90149-04278	.SCREW	3	3		
14	98507-05020	.SCREW, PAN HEAD	1	1		
15	95607-05100	.NUT, U	1	1		
16	95307-05700	.NUT	1	1		
17	93104-09025	.OIL SEAL	1	1		
18	1NV-26304-00	.SPRING	1	1		
19	4KB-2628G-00	.GASKET	1	1		
20	1NV-26129-00	.WASHER	1	1		
21	1NV-26398-00	.WASHER	1	1		
22	4V4-82913-00	HOLDER, LEVER LOWER 1	1	1		
23	98502-05020	SCREW, PAN HEAD	2	2		
24	92902-05600	WASHER, PLATE	2	2		
25	3FA-26373-00	CABLE, BRAKE 4	1	1		
26	52H-26371-00	HOUSING, BRAKE LINK	1	1		
27	52H-26347-01	JOINT, CABLE	1	1		

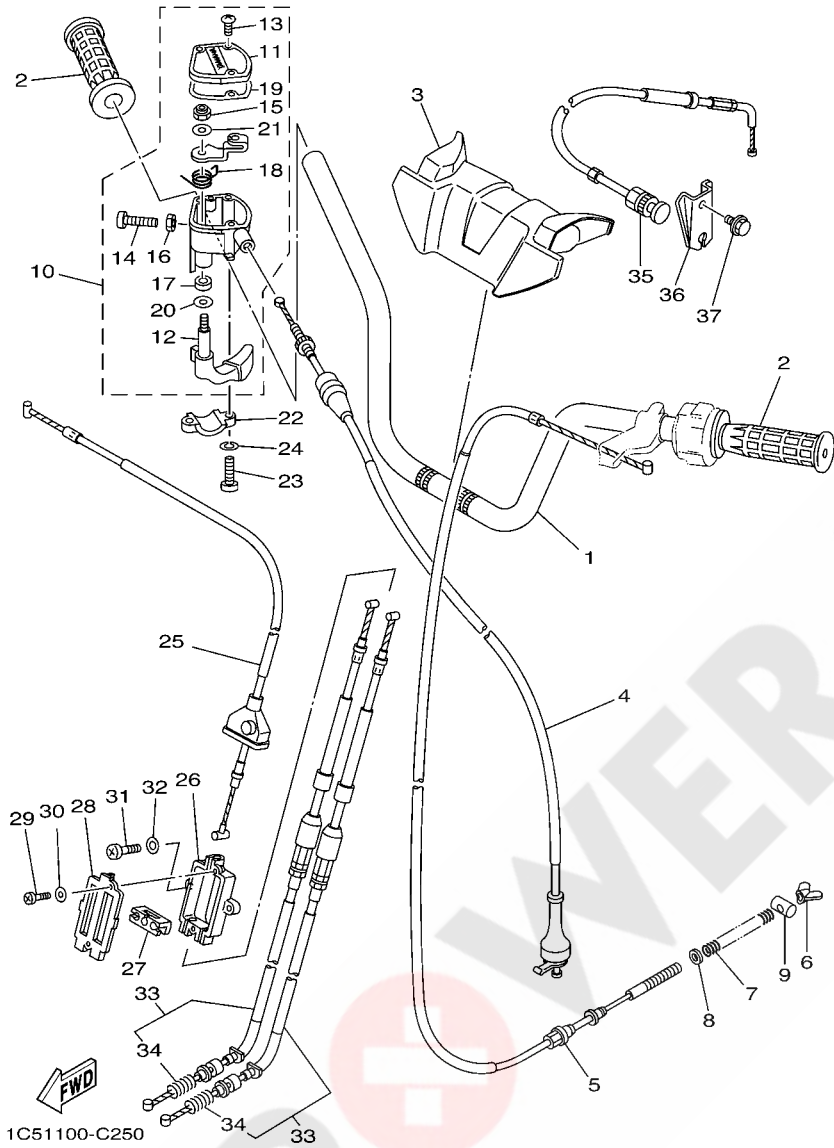
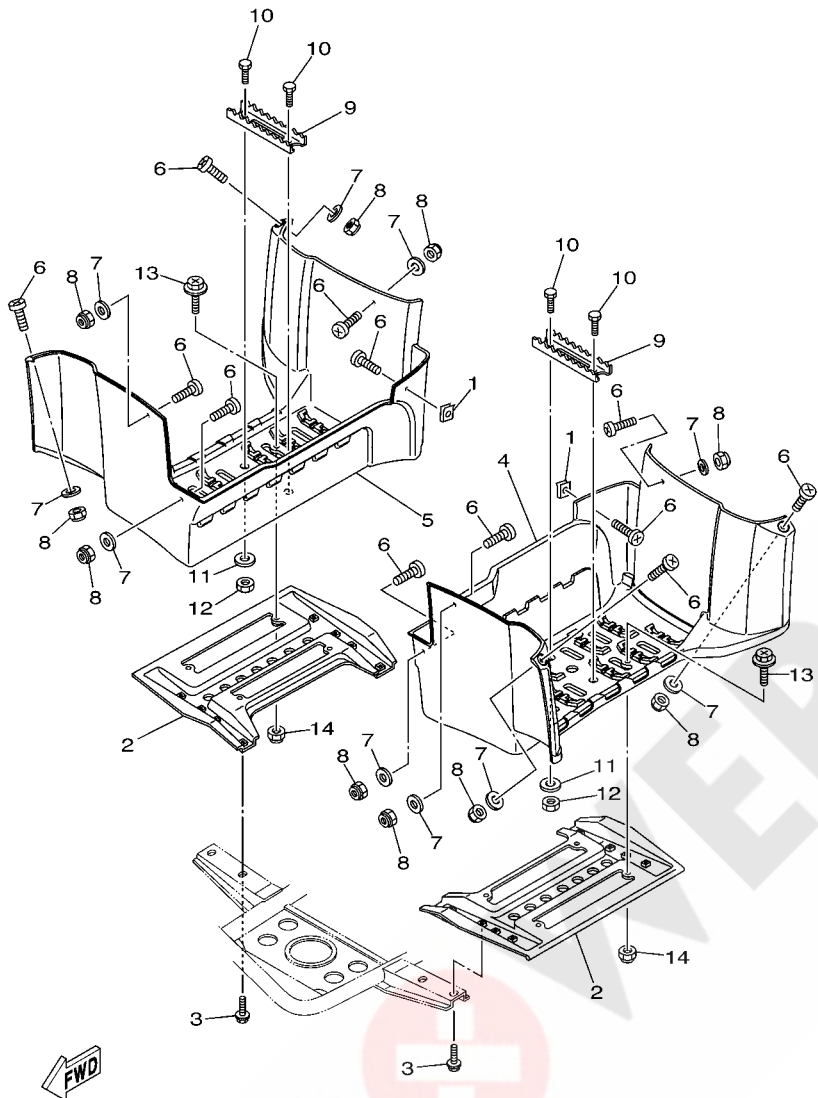

FIG. 25 STEERING HANDLE & CABLE

REF. NO.	PART NO.	DESCRIPTION	EUR	JPN			REMARKS
28	52H-2631G-00	PLATE	1	1			
29	98502-03008	SCREW, PAN HEAD	2	2			
30	92902-03600	WASHER, PLATE	2	2			
31	98502-05016	SCREW, PAN HEAD	2	2			
32	92902-05600	WASHER, PLATE	2	2			
33	3FA-26361-10	CABLE, BRAKE	2	2			
34	90501-08511	.SPRING, COMPRESSION	1	1			
35	3FA-26331-01	CABLE, STARTER 1	1	1			
36	1C5-26393-00	HOLDER	1	1			
37	95822-06010	BOLT, FLANGE	1	1			



1C51100-C260

FIG. 26 STAND & FOOTREST

REF. NO.	PART NO.	DESCRIPTION	EUR	JPN	REMARKS
1	90183-06053	NUT, SPRING	2	2	
2	3FA-27411-10	FOOTREST 1	2	2	
3	95812-08014	BOLT, FLANGE	8	8	
4	1C5-27453-00	COVER 1	1	1	
5	1C5-27463-00	COVER 2	1	1	
6	98902-06020	SCREW, BIND	12	12	
7	90201-06032	WASHER, PLATE	10	10	
8	95702-06300	NUT, NYLON	10	10	
9	5GH-2741A-10	ARM 1	2	2	
10	90109-06214	BOLT	4	4	
11	90201-06033	WASHER, PLATE	4	4	
12	95312-06600	NUT	4	4	
13	90119-05021	BOLT, WITH WASHER	8	8	
14	95702-05300	NUT, NYLON	8	8	

FIG. 27 GUARD

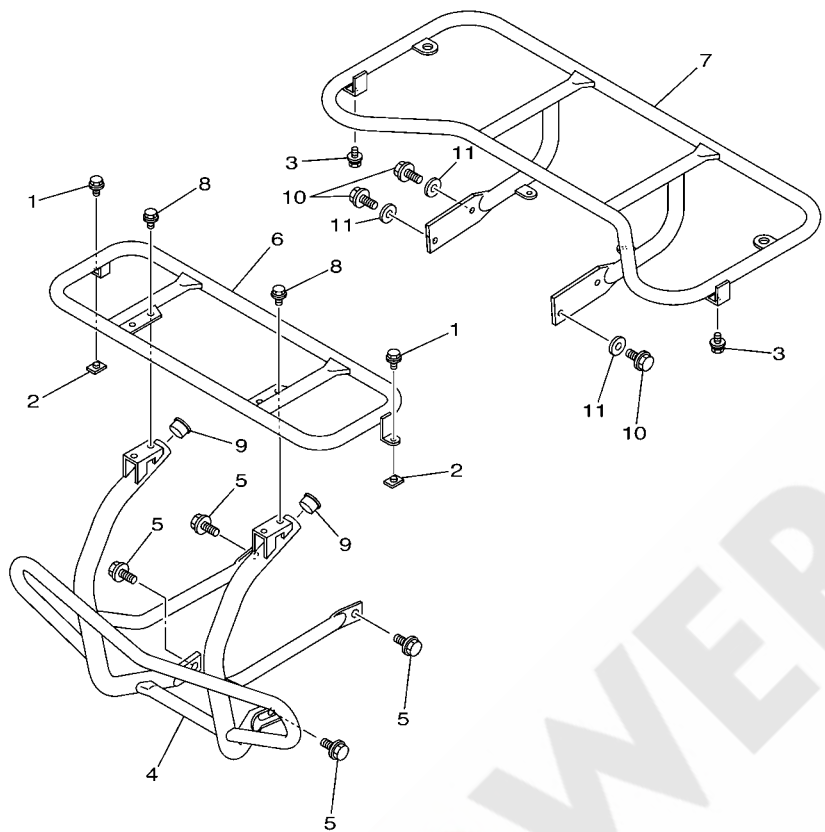

1C51110-C270

REF. NO.	PART NO.	DESCRIPTION	EUR	JPN			REMARKS
1	95802-06010	BOLT, FLANGE	2	2			
2	90179-06055	NUT	2	2			
3	90119-06152	BOLT, WITH WASHER	2	2			
4	1C5-2845N-00	BAR, CARRY FRONT	1	1			
5	95812-08016	BOLT, FLANGE	4	4			
6	1C5-24841-00	CARRIER, FRONT	1	1			
7	1C5-24842-00	CARRIER, REAR	1	1			
8	95802-06010	BOLT, FLANGE	4	4			
9	90338-23172	PLUG	2	2			
10	95812-08016	BOLT, FLANGE	3	3			
11	90201-08043	WASHER, PLATE	3	3			



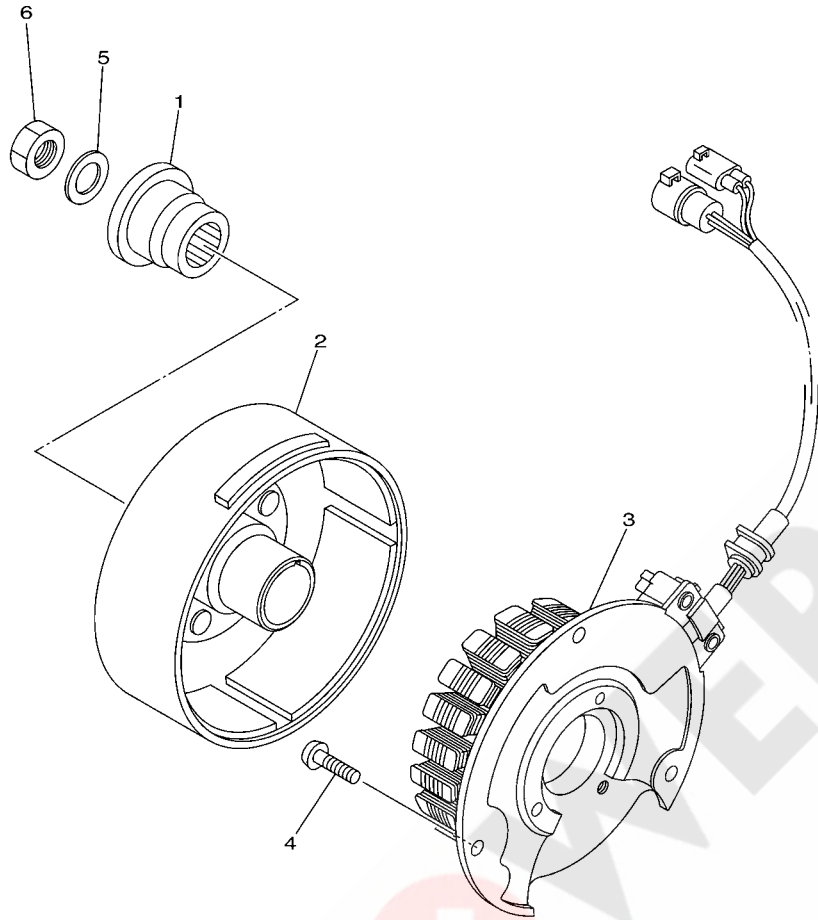

1C51100-C280

FIG. 28 GENERATOR

REF. NO.	PART NO.	DESCRIPTION	EUR	JPN				REMARKS
1	3FA-15724-00	SPACER	1	1				
2	1C5-81450-01	ROTOR ASSY	1	1				
3	1C5-81410-00	STATOR ASSY	1	1				
4	92012-06020	BOLT, BUTTON HEAD	3	3				
5	90201-12030	WASHER, PLATE	1	1				
6	90170-12181	NUT	1	1				

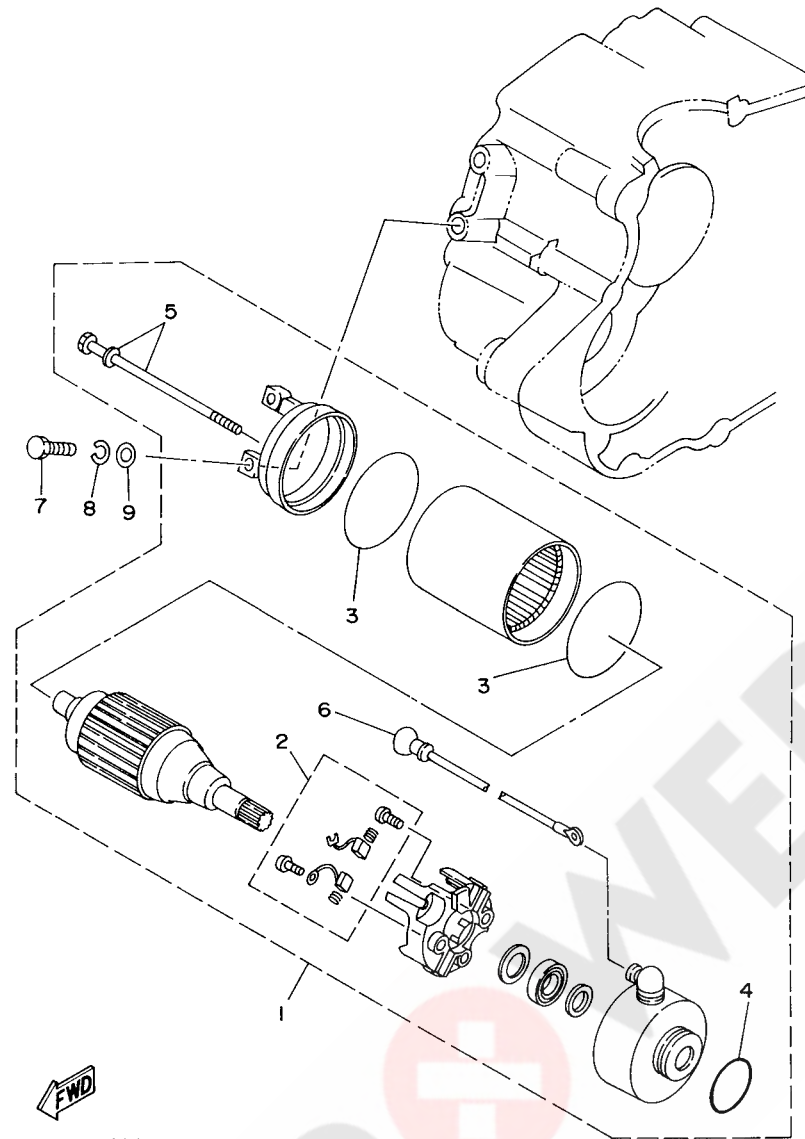

3FA9010-3290

FIG. 29 STARTING MOTOR

REF. NO.	PART NO.	DESCRIPTION	EUR	JPN			REMARKS
1	3FA-81800-01	STARTING MOTOR ASSY	1	1			
2	50M-81801-M0	.BRUSH SET	1	1			
3	93210-55669	.O-RING	2	2			
4	93210-25711	.O-RING	1	1			
5	3FA-81828-00	.BOLT 2	2	2			
6	3FA-8183G-00	.CORD COMP.	1	1			
7	97002-06025	BOLT	2	2			
8	92902-06100	WASHER, SPRING	2	2			
9	92902-06600	WASHER, PLATE	2	2			

**FIG. 30 HEADLIGHT**

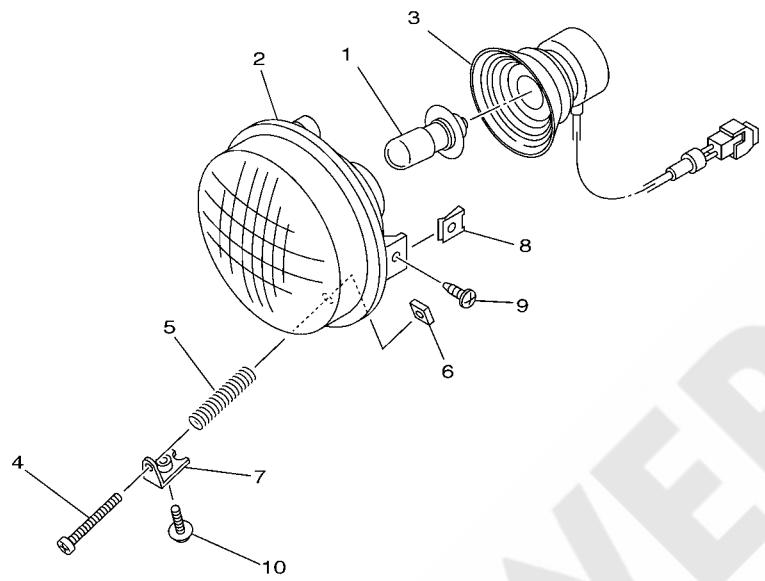

REF. NO.	PART NO.	DESCRIPTION	EUR	JPN	REMARKS
1	4KB-84314-01	BULB (12V-30/30W)	2	2	
2	5KM-84320-01	LENS ASSY	2	2	
3	5EH-84340-00	SOCKET CORD ASSY 1	2	2	
4	98502-03540	SCREW, PAN HEAD	2	2	
5	2GU-84332-00	SPRING, SCREW	2	2	
6	2GU-84334-00	NUT, ADJUSTING	2	2	
7	5KM-84703-10	BRACKET	2	2	
8	90183-05008	NUT, SPRING	4	4	
9	90154-05021	SCREW, BINDING	4	4	
10	90159-05044	SCREW, WITH WASHER	2	2	



5KM1100-2450

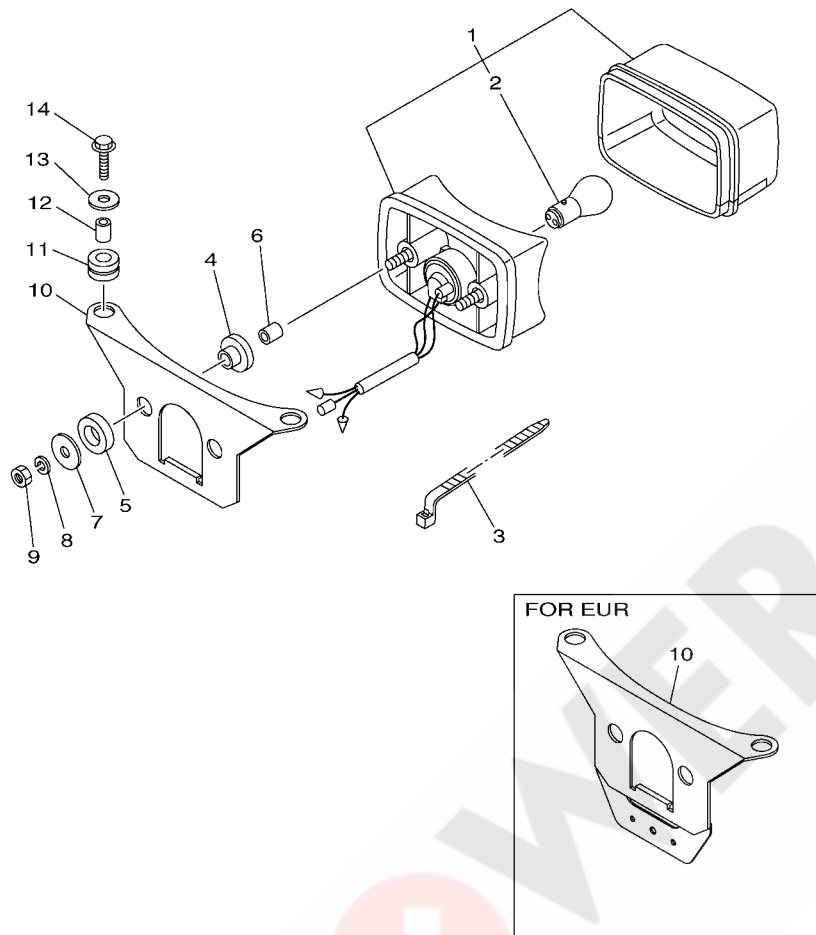

  
1C5U300-K310

FIG. 31 TAILLIGHT

REF. NO.	PART NO.	DESCRIPTION	EUR	JPN		REMARKS
1	3FA-84710-00	TAILLIGHT UNIT ASSY	1	1		
2	1A2-84714-41	.BULB (12V-21/5W)	1	1		
3	90464-15195	CLAMP	1	1		
4	90480-14088	GROMMET	2	2		
5	90202-14077	WASHER, PLATE	2	2		
6	90387-06201	COLLAR	2	2		
7	90201-06097	WASHER, PLATE	2	2		
8	92902-06100	WASHER, SPRING	2	2		
9	95302-06600	NUT	2	2		
10	3FA-84702-30	BRACKET, TAILLIGHT	1			
	3FA-84702-10	BRACKET, TAILLIGHT		1		
11	90480-14555	GROMMET	2	2		
12	90387-065L7	COLLAR	2	2		
13	90201-06033	WASHER, PLATE	2	2		
14	95802-06025	BOLT, FLANGE	2	2		

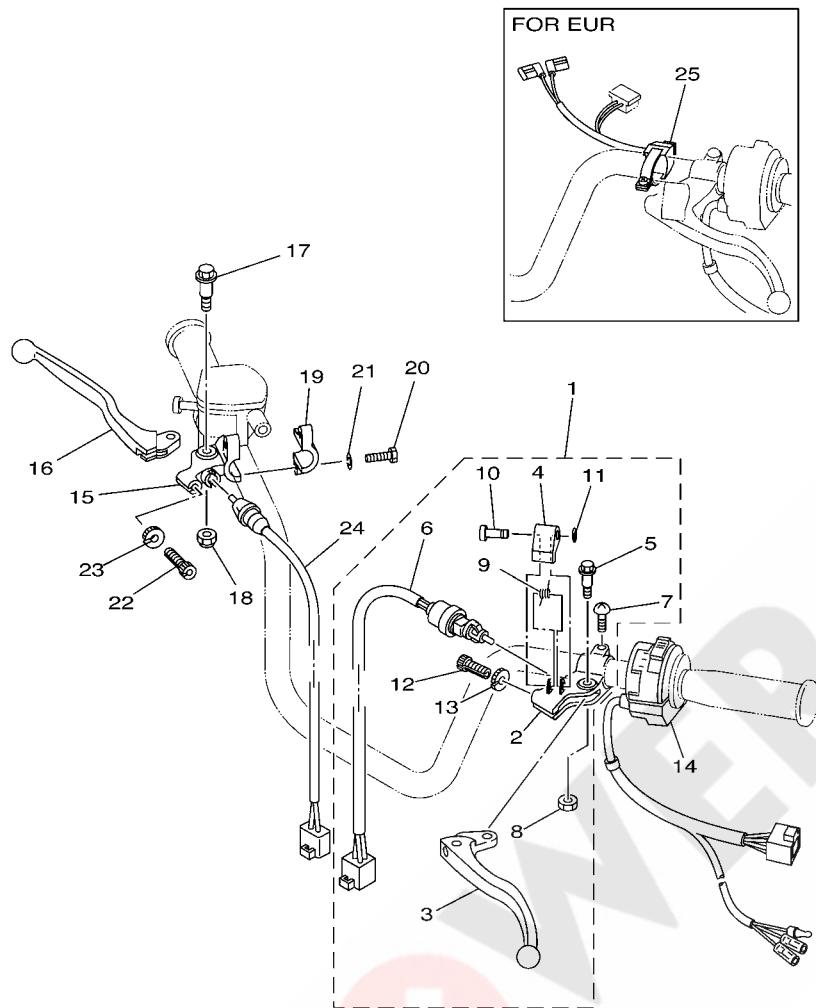

  
 1C51100-C320

**FIG. 32 HANDLE SWITCH & LEVER**

REF. NO.	PART NO.	DESCRIPTION	EUR	JPN	REMARKS
1	3FA-82910-23	LEVER HOLDER ASSY (LEFT)	1	1	
2	3FA-82911-01	.HOLDER, LEVER 1	1	1	
3	2HT-83912-00	.LEVER 1	1	1	
4	3FA-83965-00	.LEVER, LOCK	1	1	
5	90109-06799	.BOLT	1	1	
6	3FA-83980-03	.FRONT STOP SWITCH ASSY	1	1	
7	98507-06020	.SCREW, PAN HEAD	1	1	
8	95607-06100	.NUT, U	1	1	
9	3FA-83966-00	.SPRING, RETURN	1	1	
10	3FA-83967-00	.PIN, LOCK 1	1	1	
11	3FA-26466-00	.RING, SNAP	1	1	
12	90123-08046	.BOLT	1	1	
13	90179-08148	.NUT	1	1	
14	4KB-83973-21	SWITCH, HANDLE 3	1	1	
15	3JN-82921-00	HOLDER, LEVER 2	1	1	
16	59V-83922-00	LEVER 2	1	1	
17	90109-06799	BOLT	1	1	
18	95607-06100	NUT, U	1	1	
19	2XJ-82913-00	HOLDER, LEVER LOWER 1	1	1	
20	97027-06025	BOLT, HEXAGON	2	2	
21	92907-06100	WASHER, SPRING	2	2	
22	90123-08046	BOLT	1	1	
23	90179-08148	NUT	1	1	
24	3FA-83980-10	FRONT STOP SWITCH ASSY	1	1	
25	1C5-83976-00	SWITCH, HANDLE 1	1		

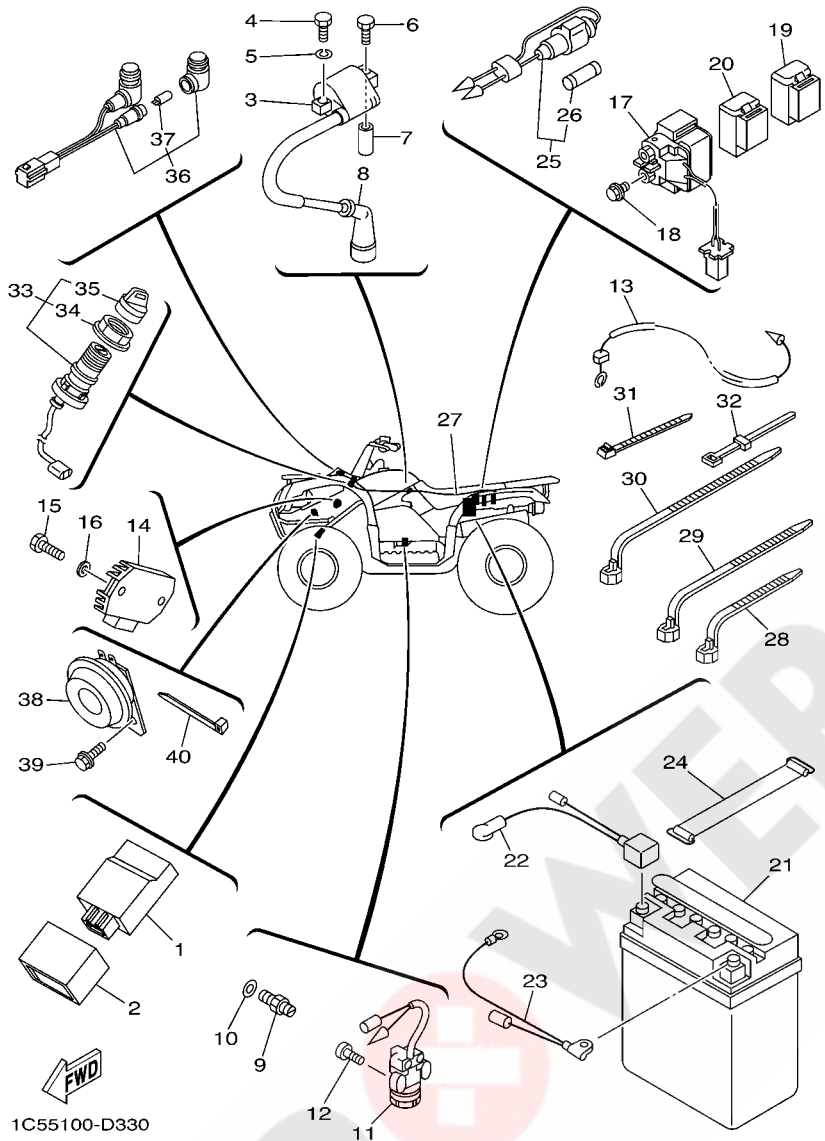

FIG. 33 ELECTRICAL 1

REF. NO.	PART NO.	DESCRIPTION	EUR	JPN		REMARKS
1	3FA-85540-20	C.D.I. UNIT ASSY	1	1		
2	5HP-85546-00	BAND	1	1		
3	4KJ-82310-10	IGNITION COIL ASSY	1	1		
4	97002-06020	BOLT	1	1		
5	92902-06100	WASHER, SPRING	1	1		
6	90109-06723	BOLT	1	1		
7	90445-072A4	HOSE (L15)	1	1		
8	1UY-82370-20	PLUG CAP ASSY	1	1		
9	4KM-82540-00	NEUTRAL SWITCH ASSY	1	1		
10	90430-10148	GASKET	1	1		
11	3FA-82627-00	SWITCH	1	1		
12	90149-05024	SCREW	2	2		
13	3FA-82541-00	WIRE, LEAD	1	1		
14	5GT-81960-00	RECTIFIER & REGULATOR ASSY	1	1		
15	97002-06020	BOLT	2	2		
16	92902-06600	WASHER, PLATE	2	2		
17	3MW-81940-01	STARTER RELAY ASSY	1	1		
18	95022-06008	BOLT, FLANGE	2	2		
19	29U-81950-93	RELAY ASSY	1	1		
20	2NL-81950-92	RELAY ASSY	1	1		
21	3FA-82110-12	BATTERY ASSY (GS 12N12C-4A-2)	1			
	90793-26276	BATTERY ASSY (GS 12N12C-4A-2)		1		
22	3FA-82115-01	WIRE, PLUS LEAD	1	1		
23	3FA-82116-00	WIRE, MINUS LEAD	1	1		
24	133-82131-00	BAND, BATTERY	1	1		
25	1UY-82150-00	FUSE HOLDER ASSY	1	1		
26	1UY-82151-00	.FUSE (15A)	2	2		

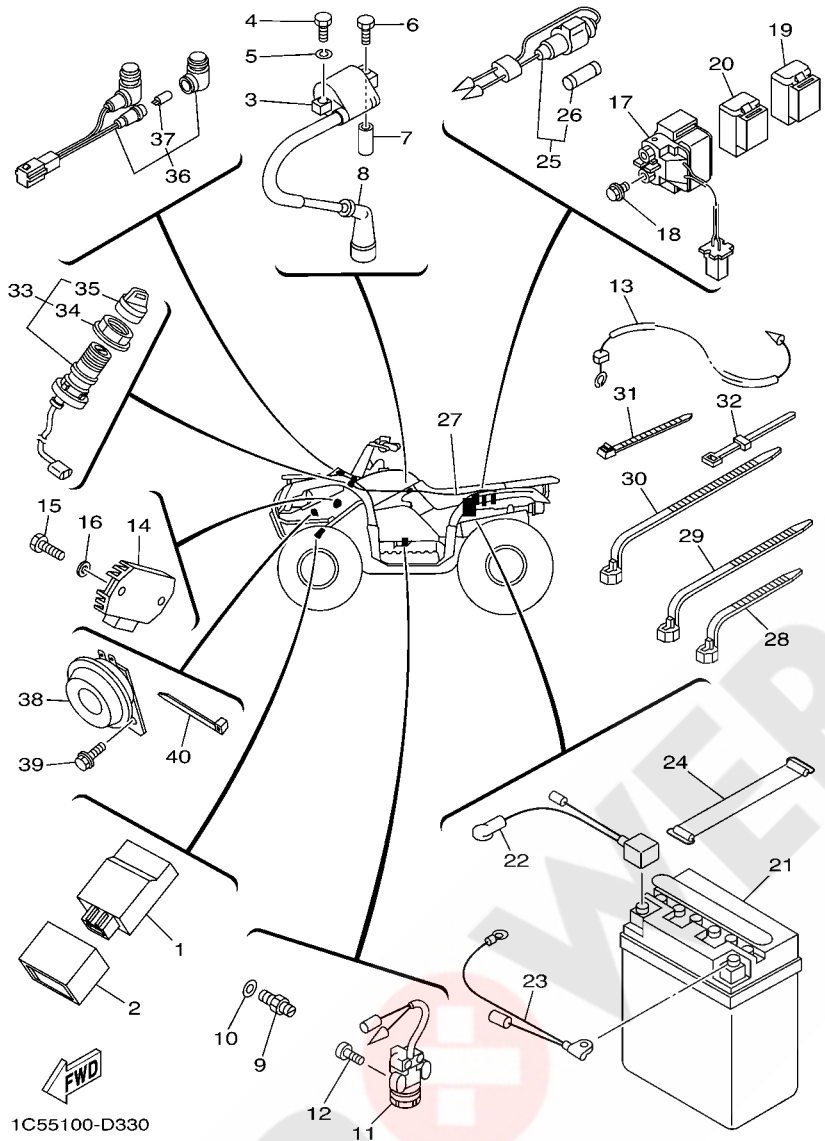
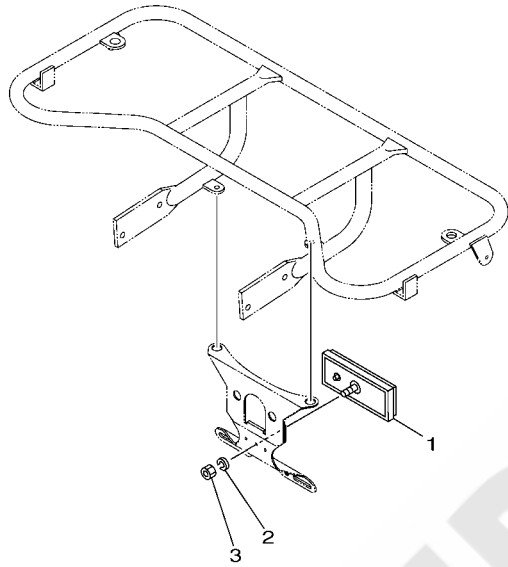

FIG. 33 ELECTRICAL 1

REF. NO.	PART NO.	DESCRIPTION	EUR	JPN	REMARKS
27	1C5-82590-10	WIRE HARNESS ASSY	1		
	1C5-82590-00	WIRE HARNESS ASSY		1	
28	90464-13073	CLAMP	4	4	
29	90464-15195	CLAMP	1	1	
30	90464-12045	CLAMP	1	1	
31	90465-10098	CLAMP	1	1	
32	437-83936-01	BAND, SWITCH CORD	4	4	
33	5LP-82510-00	MAIN SWITCH ASSY	1	1	
34	3HN-82569-00	.NUT, MAIN SWITCH	1	1	
35	3HN-82579-00	.CAP, KEY	1	1	
36	5TE-83530-00	PILOT LIGHT ASSY	1	1	
37	5GH-83516-00	.BULB (14V-1.7W)	2	2	
38	50M-83371-20	HORN	1		
39	95812-06012	BOLT, FLANGE	1		
40	90464-35132	CLAMP	1		

FIG. 34 ELECTRICAL 2



REF. NO.	PART NO.	DESCRIPTION	EUR	JPN		REMARKS
1	3Y6-85130-02	REAR REFLECTOR ASSY	1			
2	92902-05100	WASHER, SPRING	1			
3	95302-05600	NUT	1			

  
1C5U300-K340



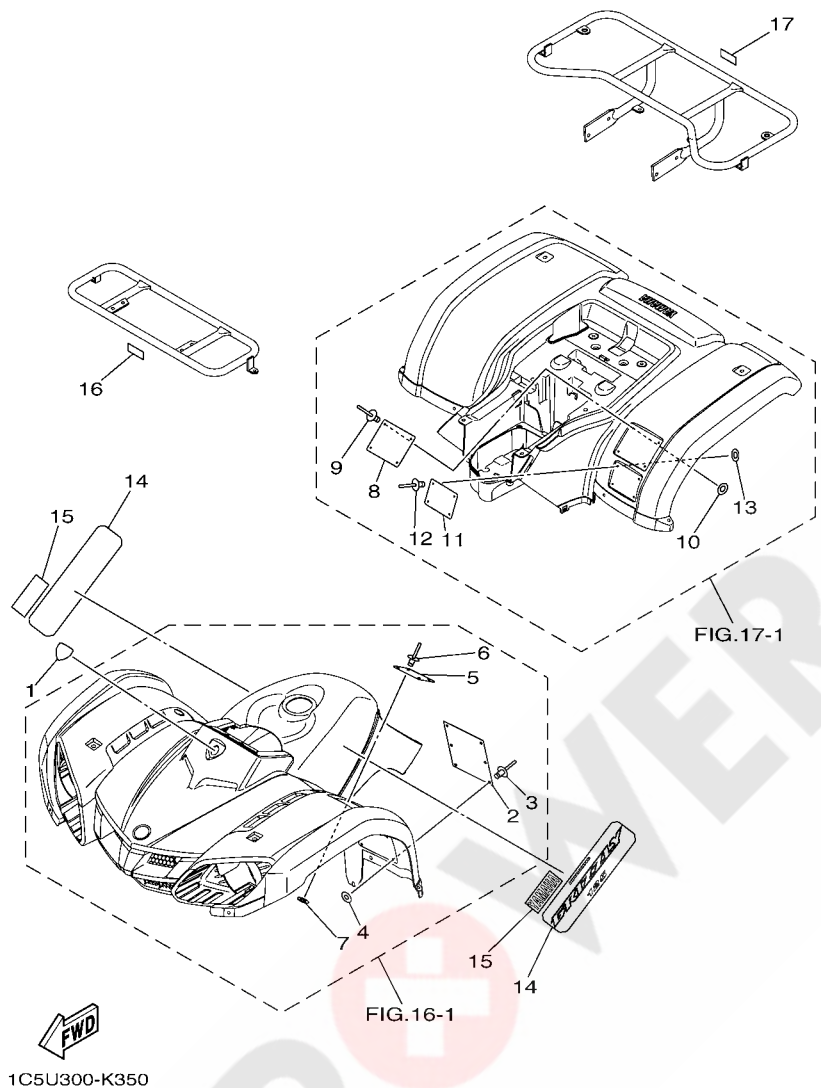

FIG. 35 EMBLEM & LABEL 1

REF. NO.	PART NO.	DESCRIPTION	EUR	JPN	REMARKS
1	3B4-26232-01	EMBLEM 3D	1		
2	43P-2816R-01	LABEL, WARNING GENERAL INFO.	1		
3	90267-32004	RIVET, BLIND	6		
4	90201-03008	WASHER, PLATE	6		
5	4D3-2816L-20	LABEL, WARNING AGE	1		
6	90267-32004	RIVET, BLIND	4		
7	90201-03008	WASHER, PLATE	4		
8	1C5-2816M-M0	LABEL, WARNING TIRE & LOAD	1		
9	90267-32004	RIVET, BLIND	4		
10	90201-03008	WASHER, PLATE	4		
11	1AS-2816P-00	LABEL, WARNING PASSENGER	1		
12	90267-32004	RIVET, BLIND	4		
13	90201-03008	WASHER, PLATE	4		
14	1C5-2173E-F0	GRAPHIC, 1	2		UR FOR PDG
	1C5-2173E-H0	GRAPHIC, 1	2		UR FOR DPBSN
15	4ES-2153E-30	EMBLEM, YAMAHA	2		
16	1C5-2817R-00	LABEL, LOAD LIMIT	1		
17	1C5-2817R-10	LABEL, LOAD LIMIT	1		

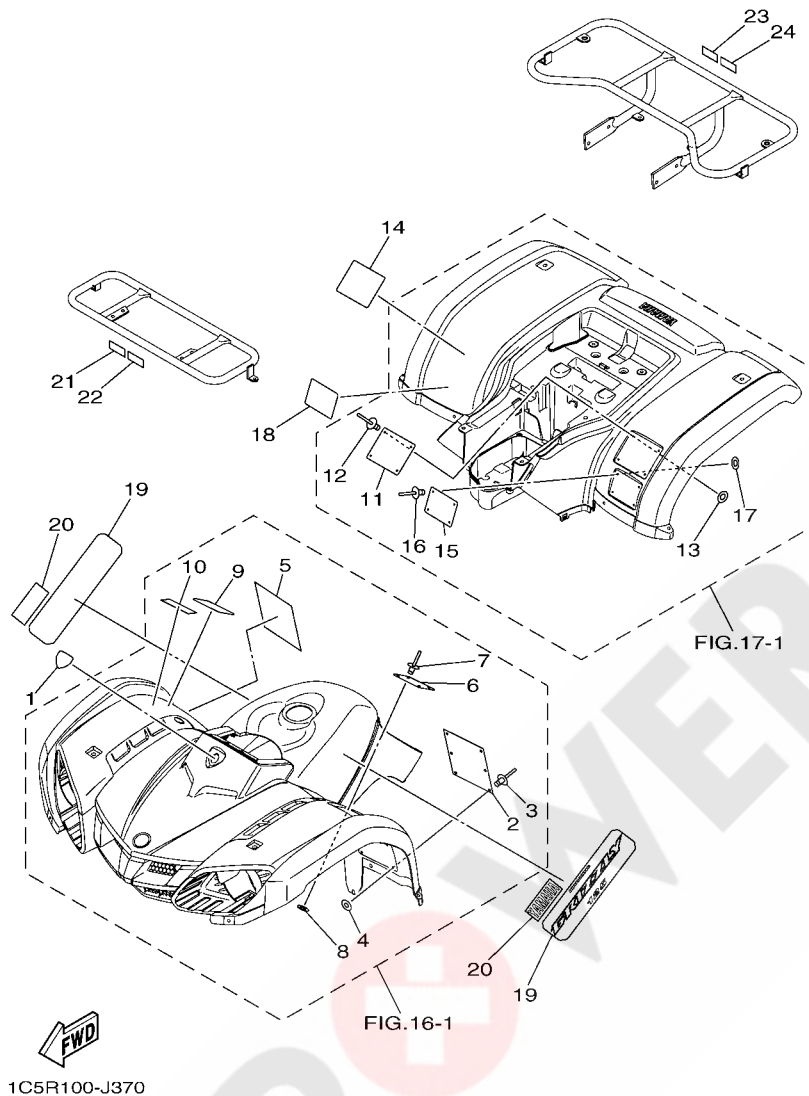

FIG. 36 EMBLEM & LABEL 2

REF. NO.	PART NO.	DESCRIPTION	EUR	JPN	REMARKS
1	3B4-26232-01	EMBLEM 3D		1	
2	5FE-21568-11	LABEL, WARNING		1	ENGLISH
3	90267-32004	RIVET, BLIND		6	
4	90201-03008	WASHER, PLATE		6	
5	4SH-21568-00	LABEL, WARNING		1	JAPANESE
6	4D3-2816L-00	LABEL, WARNING AGE		1	ENGLISH
7	90267-32004	RIVET, BLIND		4	
8	90201-03008	WASHER, PLATE		4	
9	4SH-21697-00	LABEL, CAUTION 2		1	JAPANESE
10	5YT-2151E-50	LABEL 2		1	JAPANESE
11	1C5-2816M-00	LABEL, WARNING TIRE & LOAD		1	ENGLISH
12	90267-32004	RIVET, BLIND		4	
13	90201-03008	WASHER, PLATE		4	
14	1C5-2816M-20	LABEL, WARNING TIRE & LOAD		1	
15	5FE-2151H-01	LABEL 5		1	ENGLISH
16	90267-32004	RIVET, BLIND		4	
17	90201-03008	WASHER, PLATE		4	
18	4LB-2151H-02	LABEL 5		1	JAPANESE
19	1C5-2173E-F0	GRAPHIC, 1		2	FOR PDG
20	4ES-2153E-30	EMBLEM, YAMAHA		2	
21	28P-2816K-20	LABEL, WARNING CARRIER 2		1	JAPANESE
22	3AC-24877-C0	LABEL, CAUTION		1	JAPANESE
23	28P-2816K-20	LABEL, WARNING CARRIER 2		1	JAPANESE
24	4AS-24877-D0	LABEL, CAUTION		1	JAPANESE

NUMERICAL INDEX

PART NO.	REF. NO.	PART NO.	REF. NO.	PART NO.	REF. NO.	PART NO.	REF. NO.	PART NO.	REF. NO.	PART NO.	REF. NO.
3FA-11102-04	1 - 1	5VJ-1410A-00	7 - 8	3FA-15461-10	9 - 26	1C5-21110-20	15 - 1	1UY-23845-01	19 - 23	3FA-26111-20	25 - 1
4GL-1111F-00	4 - 14	3FA-14112-25	7 - 7	3FA-15462-10	9 - 13	1C5-21110-30	15 - 1	3FA-23868-30	19 - 8	1C5-26124-00	25 - 3
22F-11134-10	1 - 3	4U5-14126-00	7 - 6	3FA-15467-00	10 - 3	3FA-2115K-10	15 - 15	1UY-23894-01	19 - 10	1NV-26129-00	25 - 20
3FA-11145-00	4 - 4	21V-14131-00	7 - 2	3FA-15471-00	10 - 11	3FA-21315-00	15 - 13	1C5-24110-00	21 - 1	3B4-26232-01	35 - 1
3FA-11160-00	1 - 5	1NT-14142-12	7 - 24	3FA-15472-00	7 - 24	5YT-2151E-50	36 - 10	1C5-2414H-00	21 - 18		36 - 1
3FA-11166-00	1 - 6	18M-14144-09	7 - 9	3FA-15475-00	10 - 15	5FE-2151H-01	36 - 15	55W-24500-02	21 - 10	3GB-26241-00	25 - 2
59V-11167-00	9 - 2	21V-14146-00	7 - 13	3FA-15477-00	10 - 17	4LB-2151H-02	36 - 18	4X8-24512-00	21 - 13	4KB-26250-10	25 - 10
50M-11181-00	1 - 15	24W-14147-00	7 - 29	50M-15512-00	11 - 1	4ES-2153E-30	35 - 15	3AC-24523-00	21 - 14	1NV-2625G-01	25 - 12
22F-11186-10	1 - 10	3FA-14148-00	7 - 18	3FA-15521-00	11 - 3		36 - 20	3AJ-24534-01	21 - 11	4KB-2628F-10	25 - 11
214-11198-01	9 - 20	21V-1414M-31	7 - 15	50M-15524-00	11 - 6	4SH-21568-00	36 - 5	2FJ-24610-10	21 - 2	4KB-2628G-00	25 - 19
3FA-11310-00	1 - 19	5V7-14153-00	7 - 30	50M-15570-02	11 - 9	5FE-21568-11	36 - 2	1C5-24710-10	22 - 1	1NV-26304-00	25 - 18
3FA-11351-10	1 - 20	3X3-14169-00	7 - 5	3FA-15724-00	28 - 1	1UY-21639-00	17 - 4	1C5-24731-00	22 - 2	3FA-26311-10	25 - 4
3FA-11400-00	2 - 1	24W-14184-00	7 - 14	3FA-15787-00	9 - 25	4SH-21697-00	36 - 9	4K0-24774-01	22 - 8	52H-2631G-00	25 - 28
3FA-11500-00	2 - 7	21V-14185-00	7 - 19	3FA-16111-00	12 - 1	1C5-2171A-00	16 - 19	4K0-24775-00	22 - 7	3FA-26331-01	25 - 35
2HX-11610-00	2 - 6	127-14186-00	7 - 20	3FA-16151-00	13 - 2	1C5-2171A-10	16 - 19	29U-24776-00	22 - 6	52H-26347-01	25 - 27
2HX-11610-20	2 - 6	5HH-14190-18	7 - 21	1C5-16611-01	12 - 10	1C5-2173E-F0	35 - 14	1C5-24841-00	27 - 6	3FA-26351-03	25 - 5
2HX-11610-40	2 - 6	12R-14191-00	7 - 23	3FA-16620-00	12 - 7		36 - 19	1C5-24842-00	27 - 7	3FA-26361-10	25 - 33
3FA-11631-00-A0	2 - 3	24W-14193-00	7 - 33	14T-16626-00	12 - 8	1C5-2173E-H0	35 - 14	3AC-24877-C0	36 - 22	52H-26371-00	25 - 26
22K-11633-01	2 - 4	29U-14197-00	7 - 28	3FA-17270-00	13 - 5	5KM-2175B-00	16 - 17	4AS-24877-D0	36 - 24	3FA-26373-00	25 - 25
3FA-11636-00	2 - 3	3FA-14197-00	7 - 22	3FA-17285-00	13 - 9	3FA-22110-00-33	18 - 1	1C5-25111-00	23 - 1	1C5-26393-00	25 - 36
3FA-11638-00	2 - 3	620-1423A-66	7 - 16	3FA-17411-00	13 - 1	3FA-22126-00	18 - 9	3FA-25117-00	23 - 3	1NV-26398-00	25 - 21
5AP-12111-01	3 - 1	3FA-14412-01	6 - 5	3FA-17421-00	13 - 12	1W1-22128-00	18 - 18	3FA-25121-00	23 - 14	3FA-26466-00	32 - 11
3FA-12113-00	3 - 5	2NL-14419-00	6 - 21	3FA-17430-00	13 - 26	401-22128-01	18 - 7	52H-2513A-00	23 - 21	371-27114-00	22 - 3
22F-12116-00	3 - 4	3FA-14422-10	16 - 13	3FA-17471-01	13 - 20	2JX-22141-00	18 - 4		23 - 31	3FA-27411-10	26 - 2
22F-12117-02	3 - 7	3FA-14424-00	6 - 8	3FA-17519-10	13 - 17	2A6-22151-00	18 - 10	2N3-25155-00	24 - 14	5GH-2741A-10	26 - 9
22F-12118-01	3 - 6	3FA-14437-00	6 - 17	3FA-17551-00	13 - 16	2A6-22152-00	18 - 11	3FA-25155-00	23 - 18	1C5-27453-00	26 - 4
2HX-12119-00	3 - 3	2XJ-14451-00	6 - 13	3FA-17611-01	12 - 27	10V-22178-00	15 - 5	3FA-25156-00	23 - 28	1C5-27463-00	26 - 5
5HP-12121-00	3 - 2	36F-14452-00	6 - 6	3FA-17620-01	12 - 15	4V4-22184-00	15 - 6	3FA-25169-00	23 - 24	3GB-28100-00	15 - 17
50M-12151-00	3 - 8	3FA-14453-00	6 - 19	50W-17623-00	12 - 18	3FA-2219X-00	18 - 12	3FA-25180-00-98	23 - 6	1NV-2811A-01	15 - 18
22F-12156-00	3 - 11	59V-14457-00	6 - 9	50M-17630-00	12 - 21	3FA-22210-00-33	18 - 14	3FA-25311-00	24 - 7	28P-2816K-20	36 - 21
22F-12159-00	3 - 9	2XJ-14458-00	6 - 14	50M-17632-00	12 - 17	3FA-23350-00-33	20 - 22	3FA-25317-00	24 - 10		36 - 23
50M-12170-01	4 - 1	3FA-14461-00	16 - 14	50M-1763E-01	12 - 24	1C5-23391-00	16 - 5	3FA-2531E-00	24 - 29	4D3-2816L-00	36 - 6
50M-12176-00	4 - 2	3FA-14472-00	6 - 7	3FA-17641-00	12 - 26	2HR-23442-00	19 - 3	3FA-25336-00	24 - 32	4D3-2816L-20	35 - 5
50M-12210-00	4 - 10	583-14561-00	7 - 17	4CW-17653-00	12 - 19	3GB-23448-00	20 - 7	23F-2533A-00	24 - 17	1C5-2816M-00	36 - 11
4RF-12213-00	4 - 11	3DM-14613-00	8 - 9	3FA-17660-02	12 - 30	3FA-23511-01	20 - 1	3FA-25343-00	24 - 26	1C5-2816M-20	36 - 14
50M-12231-00	4 - 8	3FA-14628-00	8 - 1	50W-17664-00	12 - 34	2NL-23517-00	20 - 8	55X-25351-00	24 - 13	1C5-2816M-M0	35 - 8
50M-12241-00	4 - 9	3FA-14711-00	8 - 2	3FA-17670-00	12 - 31	5YT-23517-00	20 - 17	5G3-25351-02	23 - 17	1AS-2816P-00	35 - 11
3FA-13300-00	5 - 1	55X-14752-00	8 - 3	50W-17674-00	12 - 35	3FA-23521-01	20 - 4		23 - 27	43P-2816R-01	35 - 2
3FA-13325-00	5 - 2	4BD-14766-00	8 - 7	3FA-17684-00	12 - 37	3FA-23570-00-33	20 - 13	5V6-25367-00	24 - 23	1C5-2817R-00	35 - 16
22F-13329-01	5 - 4	3FA-1490J-10	7 - 3	3FA-18101-01	14 - 8	3FA-23580-00-33	20 - 14	3FA-25381-10	24 - 25	1C5-2817R-10	35 - 17
3FA-13405-00	5 - 11	59V-14962-00	7 - 32	3FA-18128-00	14 - 21	1UY-23812-00	19 - 6	1C5-25383-00	24 - 1	1C5-28309-00	16 - 7
51Y-13411-00	5 - 7	3FA-15100-00	9 - 1	3FA-18152-00	14 - 11	1C5-23813-20	19 - 1	3FA-25386-00	24 - 21	5GH-28349-00	16 - 12
3Y1-13416-01	5 - 6	30X-15351-00	5 - 9	3FA-18164-00	14 - 12	8K1-23814-00	19 - 4	1UY-25388-00	24 - 50	5GT-2836B-10	16 - 18
3FA-13586-00	6 - 1	3FA-15362-00	10 - 9	3FA-18174-00	14 - 17	3FA-23831-10	19 - 15	3FA-25390-00-98	24 - 3	1C5-2845N-00	27 - 4
5VJ-14101-10	7 - 1	50M-15381-00	12 - 13	3FA-18191-00	14 - 23		19 - 20	10V-25412-00	24 - 20	1C5-81410-00	28 - 3
18G-14103-00	7 - 10	3FA-15411-00	10 - 1	4GB-18512-00	14 - 6	1UY-23841-01	19 - 16	390-25412-01	24 - 30	1C5-81450-01	28 - 2
21V-14105-00	7 - 25	50M-15418-00	9 - 14	1HX-18535-00	14 - 7		19 - 21	3FA-25432-20	24 - 19	3FA-81800-01	29 - 1
10X-14106-00	7 - 4	3FA-15451-11	10 - 2	3FA-18540-00	14 - 1	1UY-23845-01	19 - 18	55X-25715-00	24 - 35	50M-81801-M0	29 - 2

NUMERICAL INDEX

PART NO.	REF. NO.	PART NO.	REF. NO.	PART NO.	REF. NO.	PART NO.	REF. NO.	PART NO.	REF. NO.	PART NO.	REF. NO.
3FA-81828-00	29 - 5	5KM-84703-10	30 - 7	90123-08046	32 - 12	90201-03008	36 - 4	90267-32004	36 - 16	90467-13064	1 - 7
3FA-8183G-00	29 - 6	3FA-84710-00	31 - 1		32 - 22		36 - 8	90269-05055	14 - 18		9 - 5
3MW-81940-01	33 - 17	1A2-84714-41	31 - 2	90149-04278	25 - 13		36 - 13	90269-07076	16 - 6	90467-220A1	6 - 10
2NL-81950-92	33 - 20	3Y6-85130-02	34 - 1	90149-05024	33 - 12		36 - 17	90280-03047	2 - 2	90480-01400	21 - 4
29U-81950-93	33 - 19	3FA-85540-20	33 - 1	90149-06108	21 - 15	90201-06032	26 - 7	90336-22056	19 - 2	90480-13018	9 - 24
5GT-81960-00	33 - 14	5HP-85546-00	33 - 2	90150-06016	16 - 10	90201-06033	26 - 11	90338-23172	27 - 9	90480-14088	31 - 4
3FA-82110-12	33 - 21	1C5-W215B-02	16 - 1		16 - 21		31 - 13	90340-14036	9 - 23	90480-14555	31 - 11
3FA-82115-01	33 - 22	1C5-W215B-12	16 - 1	90154-05021	30 - 9	90201-06090	21 - 6	90340-14117	9 - 31	90480-18290	21 - 8
3FA-82116-00	33 - 23	1C5-W215D-02	16 - 1	90155-06001	5 - 5	90201-06097	31 - 7	90340-14132	9 - 21	90501-08511	25 - 34
29W-82123-00	17 - 3	1C5-W216B-02	17 - 1	90159-05044	30 - 10	90201-06412	12 - 5	90340-36078	9 - 33	90501-10353	14 - 3
133-82131-00	33 - 24	1C5-W216B-11	17 - 1	90159-05045	6 - 11	90201-06630	10 - 8	90381-15040	15 - 10	90501-122E1	25 - 7
1UY-82150-00	33 - 25	1C5-W216D-00	17 - 1	90170-05302	3 - 10	90201-08043	27 - 11	90381-15088	20 - 15	90501-18576	5 - 8
1UY-82151-00	33 - 26	4BE-W2536-00	23 - 15	90170-10010	19 - 19	90201-08048	4 - 5	90381-17067	20 - 2	90501-505F1	12 - 36
4KJ-82310-10	33 - 3		23 - 25		19 - 24		8 - 12		20 - 5	90506-15260	23 - 16
1UY-82370-20	33 - 8	3FA-W253A-00	24 - 11	90170-10011	24 - 22	90201-08087	9 - 12	90386-18028	18 - 8		23 - 26
5LP-82510-00	33 - 33	90101-06046	23 - 19	90170-12011	12 - 29	90201-08609	1 - 12	90387-06153	16 - 4		24 - 12
4KM-82540-00	33 - 9		23 - 29	90170-12181	28 - 6	90201-10036	19 - 12	90387-06201	31 - 6	90508-12761	14 - 24
3FA-82541-00	33 - 13		24 - 15	90170-33011	24 - 27	90201-10052	24 - 44	90387-065L7	31 - 12	90508-20779	22 - 9
3HN-82569-00	33 - 34	90101-08055	4 - 6	90170-36279	12 - 9	90201-10057	20 - 10	90387-066H4	21 - 9	90508-29760	14 - 13
3HN-82579-00	33 - 35	90101-08056	24 - 45	90171-10001	19 - 25	90201-10061	11 - 5	90387-07598	21 - 5	90560-15348	13 - 4
1C5-82590-00	33 - 27	90101-08647	24 - 51	90171-10003	20 - 11	90201-12030	28 - 5	90387-090R0	19 - 11	90793-26276	33 - 21
1C5-82590-10	33 - 27	90105-08181	1 - 13	90171-14002	23 - 12	90201-12045	18 - 5	90387-101R3	20 - 16	91312-06012	4 - 15
3FA-82627-00	33 - 11	90105-10131	18 - 15	90171-14004	24 - 48	90201-12047	18 - 19	90387-113W0	24 - 42	91312-06016	4 - 12
3FA-82910-23	32 - 1	90105-10183	15 - 2	90175-06013	25 - 6	90201-12048	24 - 43	90387-161V0	12 - 25		14 - 20
3FA-82911-01	32 - 2	90105-10233	20 - 20	90179-06055	27 - 2	90201-13409	15 - 7	90387-167L5	4 - 3	91312-06020	6 - 3
2XJ-82913-00	32 - 19	90105-10262	20 - 23	90179-08148	32 - 13	90201-14021	24 - 47	90387-175R2	23 - 10		13 - 18
4V4-82913-00	25 - 22	90105-10274	20 - 9		32 - 23	90201-14586	23 - 11	90387-251W4	13 - 21	91312-06110	1 - 18
3JN-82921-00	32 - 15	90105-10277	15 - 3	90179-10022	23 - 7	90201-15700	13 - 3	90430-06014	4 - 13	91401-20020	19 - 14
50M-83371-20	33 - 38	90105-10280	24 - 41		24 - 6	90201-163F8	11 - 10	90430-10148	33 - 10		19 - 27
5GH-83516-00	33 - 37	90105-12060	24 - 40	90179-14469	12 - 11	90201-221M8	13 - 8	90430-14043	9 - 22		20 - 12
5TE-83530-00	33 - 36	90105-14003	14 - 4	90179-20255	13 - 25	90201-252A4	13 - 13	90430-14194	14 - 5	91401-25015	14 - 16
2HT-83912-00	32 - 3	90109-06172	16 - 2	90179-55464	13 - 19	90202-08175	25 - 8	90445-072A4	33 - 7	91401-30025	18 - 20
59V-83922-00	32 - 16	90109-06189	14 - 25	90183-05008	30 - 8	90202-14077	31 - 5	90445-09304	21 - 3		23 - 13
437-83936-01	33 - 32	90109-06214	26 - 10	90183-06053	16 - 11	90206-06090	8 - 8	90445-10456	21 - 16	91401-30030	24 - 49
3FA-83965-00	32 - 4	90109-06723	33 - 6		16 - 20	90209-06096	6 - 15	90445-121F6	9 - 4	91701-08058	14 - 14
3FA-83966-00	32 - 9	90109-06799	32 - 5		26 - 1	90214-04038	12 - 23	90450-45075	6 - 12	91A20-07010	7 - 34
3FA-83967-00	32 - 10		32 - 17	90183-060A7	16 - 9	90215-14236	12 - 28		6 - 20	92012-06020	28 - 4
4KB-83973-21	32 - 14	90109-08705	15 - 8	90185-08016	15 - 9	90215-21239	13 - 24	90450-54008	10 - 16	92502-06008	7 - 31
1C5-83976-00	32 - 25	90114-10014	23 - 2	90185-10019	19 - 13	90215-22276	13 - 6	90460-58015	6 - 18	92502-06012	24 - 36
3FA-83980-03	32 - 6		24 - 2	90185-10022	15 - 4	90240-12092	18 - 17	90464-12045	33 - 30	92902-03100	7 - 12
3FA-83980-10	32 - 24	90116-06541	1 - 2		18 - 16	90249-12008	25 - 9	90464-13073	33 - 28	92902-03600	25 - 30
4KB-84314-01	30 - 1	90116-08084	24 - 28		20 - 21	90267-32004	35 - 3	90464-15195	31 - 3	92902-04100	7 - 27
5KM-84320-01	30 - 2	90116-10042	24 - 24		20 - 24		35 - 6		33 - 29	92902-05100	34 - 2
2GU-84332-00	30 - 5	90119-05021	26 - 13	90185-12007	18 - 6		35 - 9	90464-35132	33 - 40	92902-05600	16 - 16
2GU-84334-00	30 - 6	90119-06147	16 - 3	90201-03008	35 - 4		35 - 12	90465-08125	9 - 30		24 - 34
5EH-84340-00	30 - 3	90119-06152	17 - 2		35 - 7		36 - 3	90465-08127	9 - 10		25 - 24
3FA-84702-10	31 - 10		27 - 3		35 - 10		36 - 7	90465-10098	33 - 31		25 - 32
3FA-84702-30	31 - 10	90119-06201	16 - 8		35 - 13		36 - 12	90467-09006	21 - 17	92902-06100	22 - 5

NUMERICAL INDEX

PART NO.	REF. NO.	PART NO.	REF. NO.	PART NO.	REF. NO.	PART NO.	REF. NO.	PART NO.	REF. NO.	PART NO.	REF. NO.
92902-06100	29 - 8	93306-00308	23 - 4	95702-05300	26 - 14	98502-06090	10 - 6				
	31 - 8	93306-00433	12 - 3	95702-06300	26 - 8	98502-08012	9 - 11				
	33 - 5	93306-00710	24 - 8	95702-06500	6 - 4	98507-03008	21 - 12				
92902-06200	18 - 3	93306-20201	13 - 10		8 - 10	98507-05020	25 - 14				
	20 - 19	93306-20215	2 - 8	95802-06010	27 - 1	98507-06020	32 - 7				
92902-06600	8 - 5	93306-20301	13 - 27		27 - 8	98702-06016	9 - 18				
	14 - 22	93306-20336	2 - 9	95802-06012	15 - 16	98902-06010	8 - 6				
	24 - 37	93306-20401	13 - 11	95802-06025	31 - 14	98902-06020	26 - 6				
	29 - 9	93306-20532	13 - 15	95812-06012	33 - 39	98980-04012	12 - 22				
	33 - 16	93306-30201	13 - 28	95812-08014	26 - 3	99001-04600	22 - 10				
92902-08600	14 - 15	93311-43048	13 - 14	95812-08016	8 - 11	99001-05600	5 - 3				
92907-06100	32 - 21	93315-11040	11 - 2		15 - 14	99001-09600	11 - 4				
92990-10600	19 - 26	93399-99918	12 - 12		27 - 5	99001-10600	5 - 12				
93101-21170	12 - 16	93410-22039	13 - 7		27 - 10	99001-12600	14 - 9				
93102-14209	14 - 10	93440-10109	1 - 4	95822-06010	25 - 37	99009-22400	12 - 2				
93102-22294	9 - 15	93450-14088	2 - 5	95822-06025	14 - 19	99009-35700	11 - 8				
93102-22335	12 - 4	93503-08007	14 - 2	95822-06035	21 - 7	99530-10114	1 - 16				
93102-23275	23 - 5	93605-18078	9 - 16	95822-08016	18 - 13		1 - 17				
93102-30243	13 - 22	93700-06004	15 - 12	95822-08050	19 - 5		9 - 27				
93102-35349	24 - 39		18 - 2	97002-06012	22 - 4		10 - 4				
93102-40367	23 - 23		20 - 3	97002-06020	33 - 4	99530-12016	9 - 3				
	23 - 33		20 - 6		33 - 15						
93102-42260	24 - 9		20 - 18	97002-06025	29 - 7						
93104-09025	25 - 17	93834-12016	13 - 23	97022-08060	19 - 9						
93104-41119	12 - 32	93900-00022	23 - 9	97027-06025	32 - 20						
93112-31011	19 - 7		24 - 5	97802-03008	7 - 11						
93210-06564	9 - 19	94107-08008	23 - 8	98502-03008	25 - 29						
93210-08006	5 - 13	94110-08008	24 - 4	98502-03540	30 - 4						
93210-12327	23 - 22	94580-25092	4 - 7	98502-04014	7 - 26						
	23 - 32	94582-02074	24 - 53	98502-05010	24 - 33						
93210-14104	24 - 18	94701-00366	1 - 14	98502-05016	25 - 31						
93210-14369	9 - 32	94703-00366	1 - 14	98502-05020	16 - 15						
93210-15414	15 - 11	95022-06008	33 - 18		25 - 23						
93210-19123	10 - 10	95302-05600	34 - 3	98502-06008	10 - 7						
93210-25711	29 - 4	95302-06600	23 - 20	98502-06010	8 - 4						
93210-30611	6 - 2		23 - 30		12 - 6						
93210-347A1	5 - 10		24 - 16		12 - 14						
93210-357A3	9 - 34		31 - 9	98502-06016	1 - 9						
93210-41041	15 - 19	95302-08600	24 - 31	98502-06030	9 - 6						
93210-43713	12 - 33		24 - 46		9 - 28						
93210-44704	1 - 11		24 - 52		10 - 5						
93210-53679	1 - 21	95302-10700	19 - 17		10 - 13						
93210-55669	29 - 3		19 - 22	98502-06040	9 - 7						
93210-63556	1 - 8	95307-05700	25 - 16		9 - 29						
93210-704A7	9 - 17	95312-06600	26 - 12	98502-06045	10 - 14						
93210-97690	12 - 20	95607-05100	25 - 15	98502-06060	6 - 16						
93211-63688	24 - 38	95607-06100	32 - 8		9 - 8						
93306-00307	11 - 7		32 - 18	98502-06070	9 - 9						