



# PARTS CATALOGUE

**YFZ450RZ** (18P8) CANADA

**YFZ450RZ** (18P9) EUROPE

**YFZ450RZ** (18P7) OCEANIA

**YFZ450R** (18P7) JAPAN

1J18P-100E1

( )


**YAMAHA**  
**GENUINE**  
 Parts & Accessories

2011/2/4

NEWS NO.	DATE	COMMENT
PE0-MC-100052	Dec.,22,2010	FIG.9 THROTTLE BODY ASSY 1 LIST/ILLUST. CORRECTION

POWER PARTS  
BY AXQUAD

YFZ450RZ/YFZ450R  
PARTS CATALOGUE  
©2009 by Yamaha Motor Co., Ltd.  
1st edition, June 2009  
All rights reserved.  
Any reprinting or unauthorized use  
without the written permission of  
Yamaha Motor Co., Ltd.  
is expressly prohibited.  
Printed in Japan.

# FOREWORD

This Parts Catalogue is related to the parts for the model(s) on the cover page. When you are ordering replacement parts, please refer to this Parts Catalogue and quote both part numbers and part names correctly.

1. Modifications or additions which have been made after the issue of the Parts Catalogue will be announced in the Parts News.

It is advisable that you make the necessary corrections to the Parts Catalogue according to the Parts News.

2. Abbreviations

The following abbreviations are used in this Parts Catalogue.

“UR” Use specified parts number.

“UN” Use as many as needed.

“AP” Alternate Parts

“LM” Locally Made (Parts need to be ordered locally)

“F#” Frame No. (Applicable machine No.)

“O/S” Over Size

3. The number of components for assembly

- Parts, which are to be supplied in an assembly, are listed with a dot (.) in front of the part name as shown below.
- The numeral appearing to the right of each component part indicates the quantity of parts for each assembly unit.

PART NO.	DESCRIPTION	Q'TY	REMARKS
2F5-83310-60	FRONT FLASHER LIGHT ASSY	2	
115-83311-60	.BULB (6V-18W)	1	

4. Applicable colours of graphics are represented in the “REMARKS” as shown below.

PART NO.	DESCRIPTION	Q'TY	REMARKS
2N4-24110-00-X5	FUEL TANK COMP.	2	MXR
3J1-24240-10	.GRAPHIC, FUEL TANK	1	FOR MXR

5. Note that the illustrations for reference in finding parts numbers are not to be used for assembling. When assembling, please use the applicable service manual.

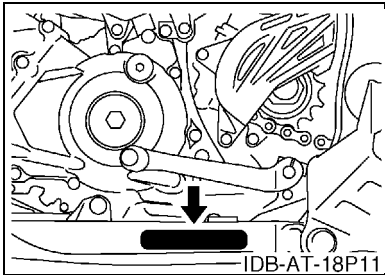
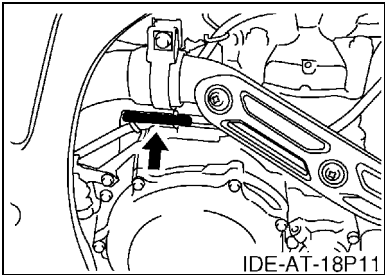
6. The asterisk (\*) before a reference number indicates modified items after the first edition.

# FOREWORD

7. Applicable Serial No.

Engine Serial No.

Frame Serial No.



8. Applicable Colour Code (The (\*) mark shows Model colour.)

Abbreviation	Colour Name	Colour Code
BWS1(*)	BLUISH WHITE SOLID 1	0892
DPBSE(*)	DEEP PURPLISH BLUE SOLID E	0583
YB	YAMAHA BLACK	0033

9. Quantity Column Information

Column No.	Name Of Q'ty Column	Destination
1	CAN	CANADA
2	EUR	EUROPE
3	OCE	OCEANIA
4	JPN	JAPAN



# CONTENTS

## ENGINE

CYLINDER .....	1
CRANKSHAFT & PISTON .....	3
VALVE .....	4
CAMSHAFT & CHAIN .....	6
WATER PUMP .....	7
RADIATOR & HOSE .....	8
OIL PUMP .....	9
INTAKE .....	10
THROTTLE BODY ASSY 1 .....	12
EXHAUST .....	13
CRANKCASE .....	14
CRANKCASE COVER 1 .....	15
STARTER .....	18
CLUTCH .....	19
TRANSMISSION .....	21
SHIFT CAM & FORK .....	23

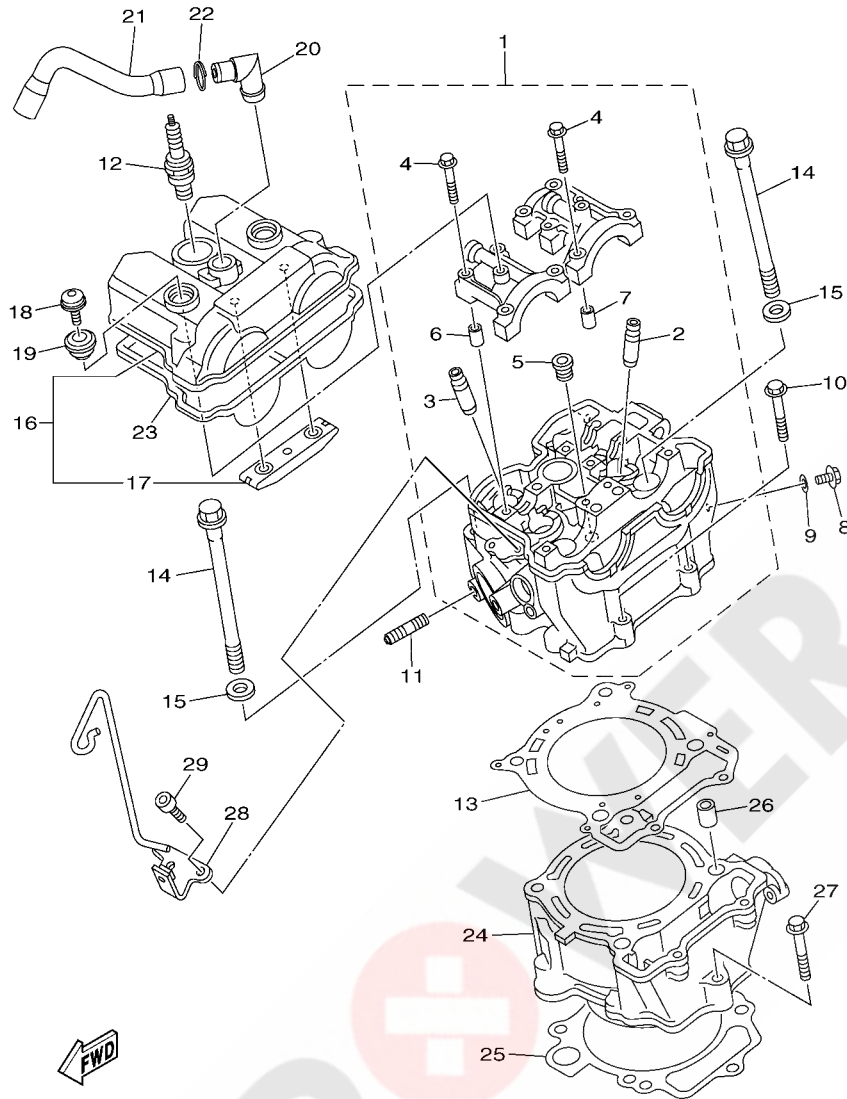
## CHASSIS

FRAME .....	25
FRONT FENDER .....	27
REAR FENDER .....	28
SIDE COVER .....	30
REAR ARM .....	32
REAR SUSPENSION .....	35
STEERING .....	36
FRONT SUSPENSION & WHEEL .....	37
FUEL TANK .....	39
SEAT .....	40
FRONT WHEEL .....	41
FRONT BRAKE CALIPER .....	42
REAR WHEEL .....	44
REAR BRAKE CALIPER .....	45
STEERING HANDLE & CABLE .....	46
FRONT MASTER CYLINDER .....	48
STAND & FOOTREST .....	49
REAR MASTER CYLINDER .....	50
GUARD .....	52
GENERATOR .....	53
STARTING MOTOR .....	54
HEADLIGHT .....	55
TAILLIGHT .....	56

TAILLIGHT 2 .....	57
HANDLE SWITCH & LEVER .....	58
ELECTRICAL 1 .....	59
ELECTRICAL 2 .....	62
GRAPHICS .....	63
EMBLEM & LABEL 1 .....	64
EMBLEM & LABEL 2 .....	65
EMBLEM & LABEL 3 .....	66
EMBLEM & LABEL 4 .....	67

## INDEX

NUMERICAL INDEX .....	68
-----------------------	----

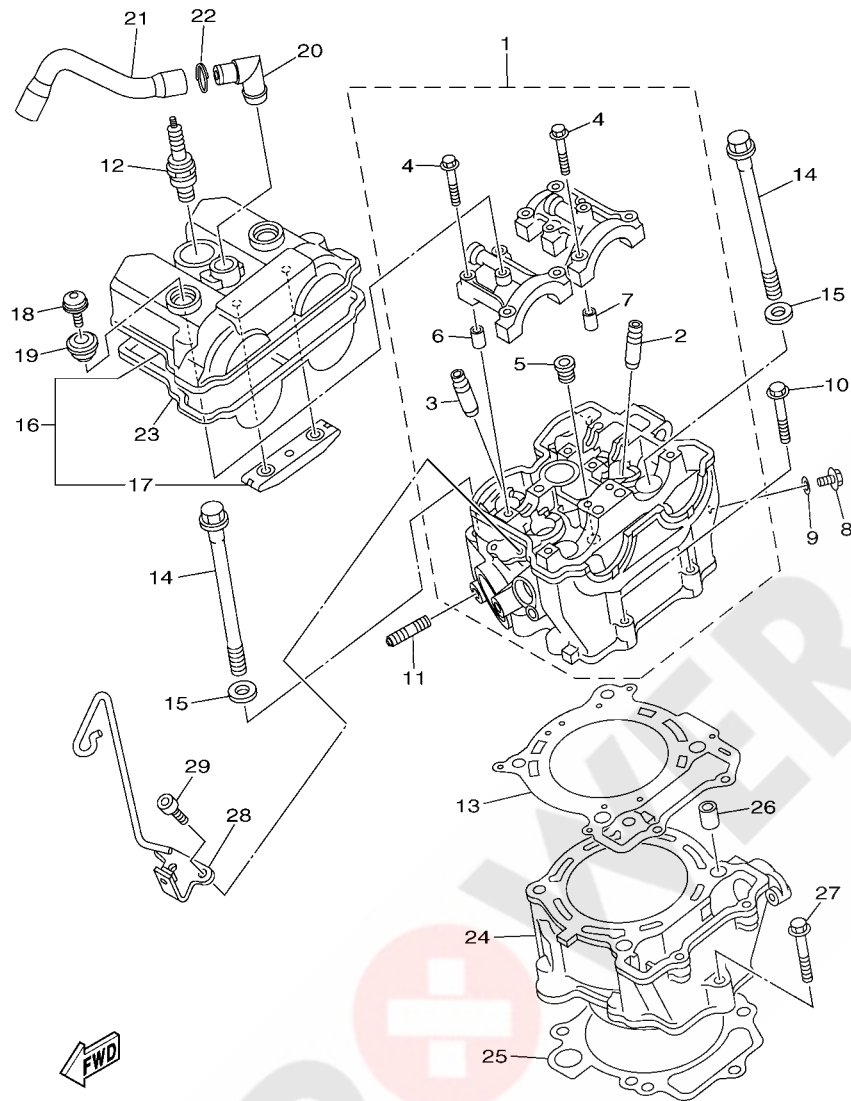


18P1100-H010

FIG. 1 CYLINDER

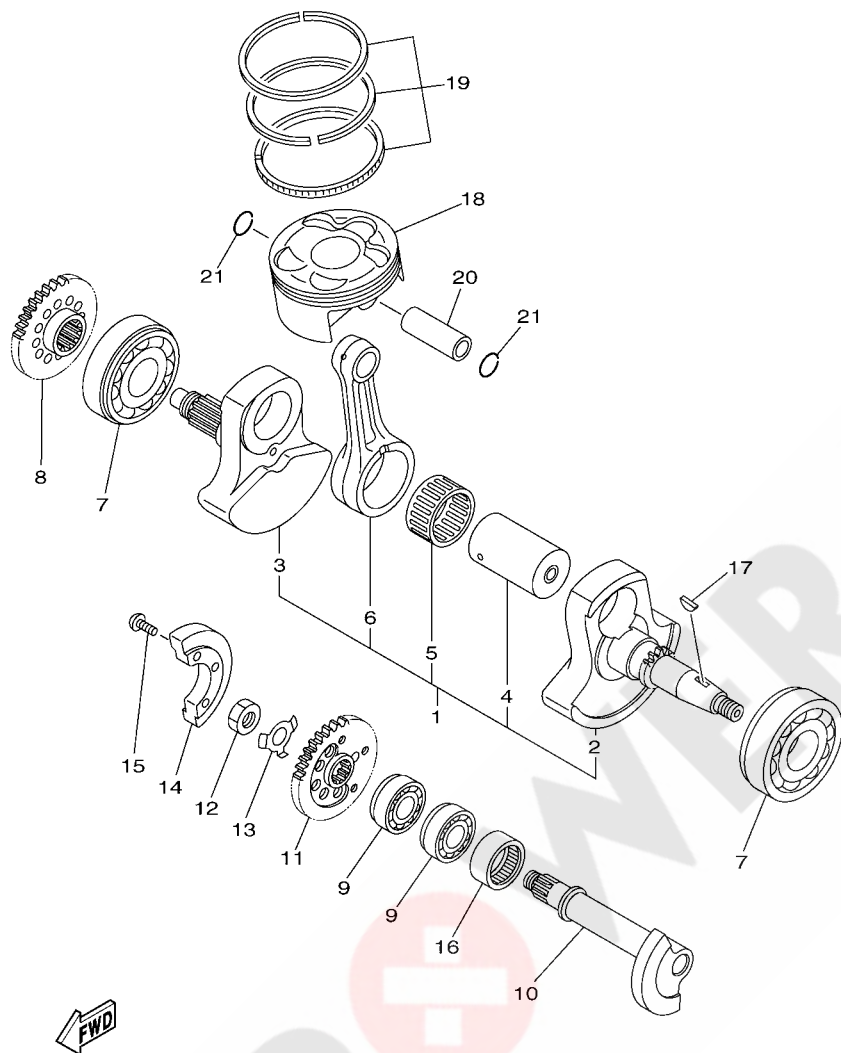
REF. NO.	PART NO.	DESCRIPTION	CAN	EUR	OC	JPN	REMARKS
1	18P-11102-00	CYLINDER HEAD ASSY	1	1	1	1	
2	5TA-11133-10	.GUIDE, VALVE 1	3	3	3	3	
3	5TA-11134-10	.GUIDE, VALVE 2	2	2	2	2	
4	90105-06027	.BOLT, FLANGE	10	10	10	10	
5	90340-12007	.PLUG, STRAIGHT SCREW	1	1	1	1	
6	91808-16023	.PIN, DOWEL	2	2	2	2	
7	91808-16023	.PIN, DOWEL	2	2	2	2	
8	95022-06010	BOLT, FLANGE	1	1	1	1	
9	90430-06014	GASKET	1	1	1	1	
10	95022-06035	BOLT, FLANGE	2	2	2	2	
11	90116-08022	BOLT, STUD	2	2	2	2	
12	94701-00330	PLUG, SPARK (NGK CR8E)	1	1	1		
	94703-00330	PLUG, SPARK (NGK CR8E)				1	
13	2S2-11181-00	GASKET, CYLINDER HEAD 1	1	1	1	1	
14	90105-10163	BOLT, FLANGE	4	4	4	4	
15	90201-10025	WASHER, PLATE	4	4	4	4	
16	2S2-11190-20	COVER, CYLINDER HEAD 1	1	1	1	1	
17	5BE-12241-00	.GUIDE, STOPPER 2	1	1	1	1	
18	90109-06203	BOLT	2	2	2	2	
19	5VY-1111G-00	RUBBER, MOUNT 1	2	2	2	2	
20	18P-11167-00	PIPE, BREATHER 2	1	1	1	1	
21	18P-11166-00	PIPE, BREATHER 1	1	1	1	1	
22	90468-100A1	CLIP	1	1	1	1	
23	2S2-11193-00	GASKET, HEAD COVER 1	1	1	1	1	
24	2S2-11311-10	CYLINDER 1	1	1	1	1	
25	2S2-11351-00	GASKET, CYLINDER	1	1	1	1	
26	93612-16254	PIN, DOWEL	2	2	2	2	

FIG. 1 CYLINDER



REF. NO.	PART NO.	DESCRIPTION	CAN	EUR	OCE	JPN	REMARKS
27	95022-06035	BOLT, FLANGE	1	1	1	1	
28	18P-11395-00	HOLDER	1	1	1	1	
29	91312-06014	BOLT	2	2	2	2	

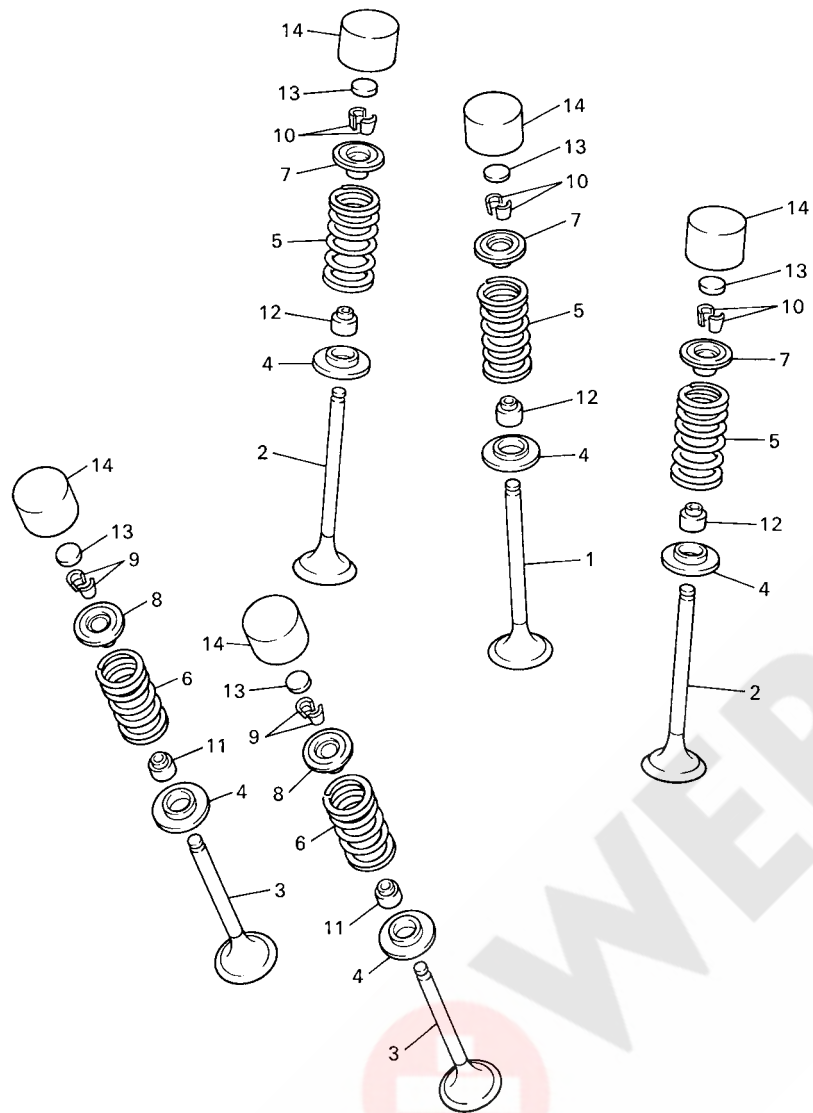




  
 18P1100-H020

**FIG. 2 CRANKSHAFT & PISTON**

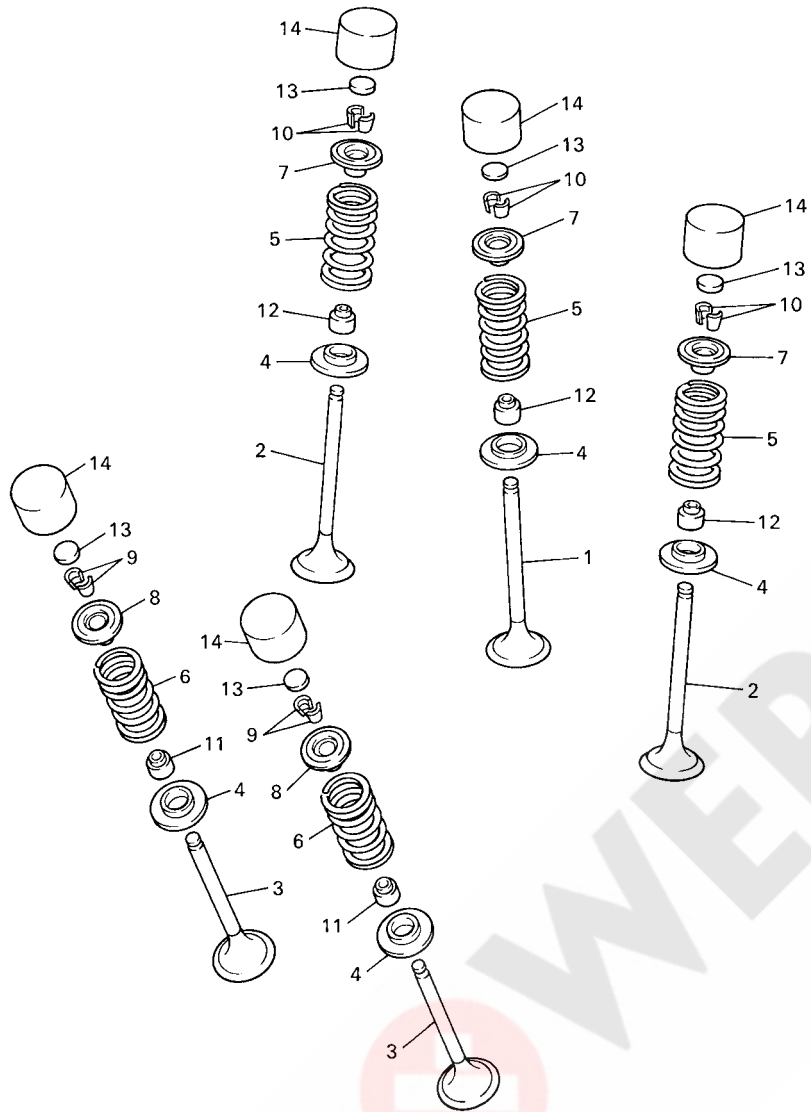
REF. NO.	PART NO.	DESCRIPTION	CAN	EUR	OC	JPN	REMARKS
1	18P-11400-00	CRANKSHAFT ASSY	1	1	1	1	
2	18P-11412-00	.CRANK 1	1	1	1	1	
3	18P-11422-00	.CRANK 2	1	1	1	1	
4	18P-11681-00	.PIN, CRANK 1	1	1	1	1	
5	93310-73606	.BEARING	1	1	1	1	
6	18P-11651-00	.ROD, CONNECTING	1	1	1	1	
7	93306-30644	BEARING	2	2	2	2	
8	18P-11536-00	GEAR, DRIVE	1	1	1	1	
9	93306-20353	BEARING	2	2	2	2	
10	18P-11455-00	SHAFT 1	1	1	1	1	
11	18P-11531-00	GEAR, BALANCE WEIGHT	1	1	1	1	
12	90170-14171	NUT	1	1	1	1	
13	90215-14287	WASHER, LOCK	1	1	1	1	
14	18P-11454-00	WEIGHT 1	1	1	1	1	
15	90149-06069	SCREW	3	3	3	3	
16	93311-62574	BEARING	1	1	1	1	
17	90280-03006	KEY, WOODRUFF	1	1	1	1	
18	5TG-11631-11	PISTON (STD)	1	1	1	1	
19	5TG-11603-00	PISTON RING SET (STD)	1	1	1	1	
20	5TG-11633-10	PIN, PISTON	1	1	1	1	
21	93450-22027	CIRCLIP	2	2	2	2	



5BE100-8030

FIG. 3 VALVE

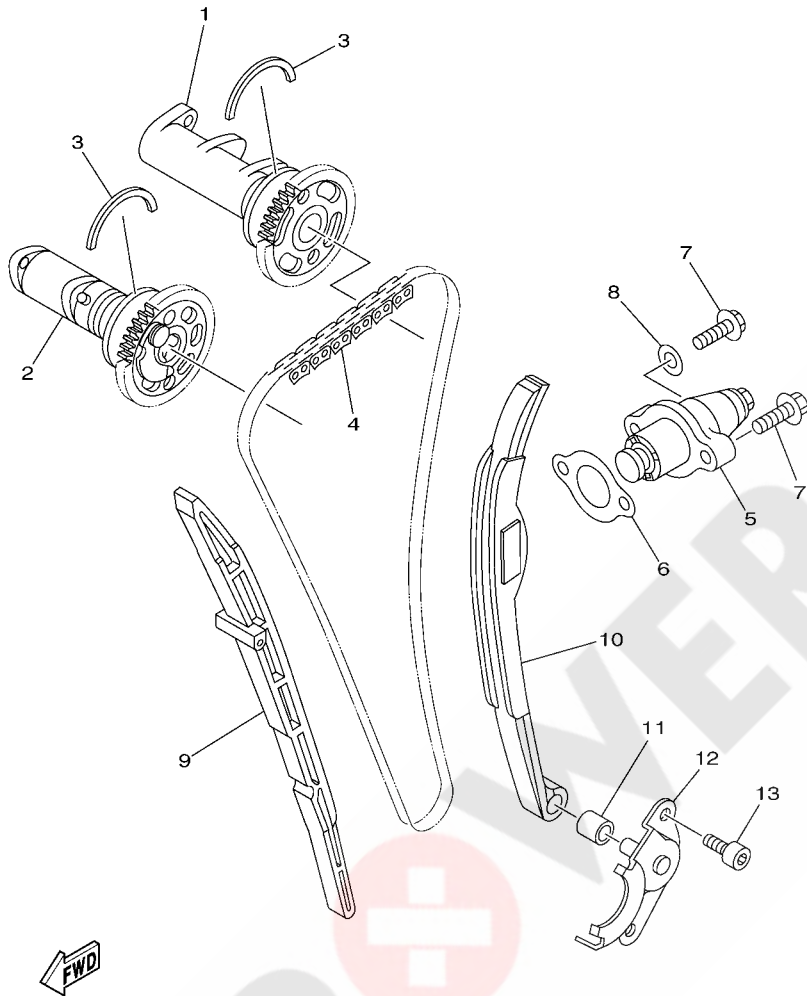
REF. NO.	PART NO.	DESCRIPTION	CAN	EUR	OC	JPN	REMARKS
1	5TA-12111-00	VALVE, INTAKE	1	1	1	1	
2	5TA-12112-00	VALVE, INTAKE 2	2	2	2	2	
3	5TA-12121-00	VALVE, EXHAUST	2	2	2	2	
4	3GM-12126-00	SEAT, VALVE SPRING 2	5	5	5	5	
5	5TJ-12113-00	SPRING, VALVE INNER	3	3	3	3	
6	5TA-12114-00	SPRING, VALVE OUTER	2	2	2	2	
7	5BE-12117-00	RETAINER, VALVE SPRING	3	3	3	3	
8	4GY-12117-00	RETAINER, VALVE SPRING	2	2	2	2	
9	1AA-12118-00	COTTER, VALVE	4	4	4	4	
10	1WG-12118-00	COTTER, VALVE	6	6	6	6	
11	33M-12119-00	SEAL, VALVE STEM	2	2	2	2	
12	4SV-12119-00	SEAL, VALVE STEM	3	3	3	3	
13	3LD-12168-00	PAD, ADJUSTING (1.20)	5	5	5	5	UR
	3LD-12168-20	PAD, ADJUSTING (1.25)	5	5	5	5	UR
	3LD-12168-40	PAD, ADJUSTING (1.30)	5	5	5	5	UR
	3LD-12168-60	PAD, ADJUSTING (1.35)	5	5	5	5	UR
	3LD-12168-80	PAD, ADJUSTING (1.40)	5	5	5	5	UR
	3LD-12168-A0	PAD, ADJUSTING (1.45)	5	5	5	5	UR
	3LD-12168-F0	PAD, ADJUSTING (1.50)	5	5	5	5	UR
	3LD-12168-H1	PAD, ADJUSTING (1.55)	5	5	5	5	UR
	3LD-12168-K1	PAD, ADJUSTING (1.60)	5	5	5	5	UR
	3LD-12168-M1	PAD, ADJUSTING (1.65)	5	5	5	5	UR
	3LD-12168-R1	PAD, ADJUSTING (1.70)	5	5	5	5	UR
	3LD-12168-U1	PAD, ADJUSTING (1.75)	5	5	5	5	UR
	3LD-12168-W1	PAD, ADJUSTING (1.80)	5	5	5	5	UR
	3LD-12168-Y1	PAD, ADJUSTING (1.85)	5	5	5	5	UR
	3LD-12169-11	PAD, ADJUSTING (1.90)	5	5	5	5	UR



5BE100-8030

FIG. 3 VALVE

REF. NO.	PART NO.	DESCRIPTION	CAN	EUR	OCE	JPN	REMARKS
13	3LD-12169-31	PAD, ADJUSTING (1.95)	5	5	5	5	UR
	3LD-12169-50	PAD, ADJUSTING (2.00)	5	5	5	5	UR
	3LD-12169-70	PAD, ADJUSTING (2.05)	5	5	5	5	UR
	3LD-12169-90	PAD, ADJUSTING (2.10)	5	5	5	5	UR
	3LD-12169-E0	PAD, ADJUSTING (2.15)	5	5	5	5	UR
	3LD-12169-G0	PAD, ADJUSTING (2.20)	5	5	5	5	UR
	3LD-12169-J0	PAD, ADJUSTING (2.25)	5	5	5	5	UR
	3LD-12169-L0	PAD, ADJUSTING (2.30)	5	5	5	5	UR
	3LD-12169-N0	PAD, ADJUSTING (2.35)	5	5	5	5	UR
	3LD-12169-T0	PAD, ADJUSTING (2.40)	5	5	5	5	UR
14	3FV-12153-10	LIFTER, VALVE	5	5	5	5	YELLOW



18P1100-H040

FIG. 4 CAMSHAFT & CHAIN

REF. NO.	PART NO.	DESCRIPTION	CAN	EUR	OCE	JPN	REMARKS
1	18P-12170-00	CAMSHAFT ASSY 1	1	1	1	1	
2	18P-12180-00	CAMSHAFT ASSY 2	1	1	1	1	
3	93440-41178	CIRCLIP	2	2	2	2	
4	94591-57120	CHAIN (98XRH2010-120M)	1	1	1	1	
5	5TA-12210-10	TENSIONER ASSY, CAM CHAIN	1	1	1	1	
6	4FM-12213-00	GASKET, TENSIONER CASE	1	1	1	1	
7	95022-06025	BOLT, FLANGE	2	2	2	2	
8	90430-06014	GASKET	1	1	1	1	
9	2S2-12251-00	DAMPER, CHAIN 1	1	1	1	1	
10	18P-12252-00	DAMPER, CHAIN 2	1	1	1	1	
11	90387-07030	COLLAR	1	1	1	1	
12	18P-12233-00	PLATE, GUIDE STOPPER 1	1	1	1	1	
13	90110-06168	BOLT, HEXAGON SOCKET HEAD	2	2	2	2	



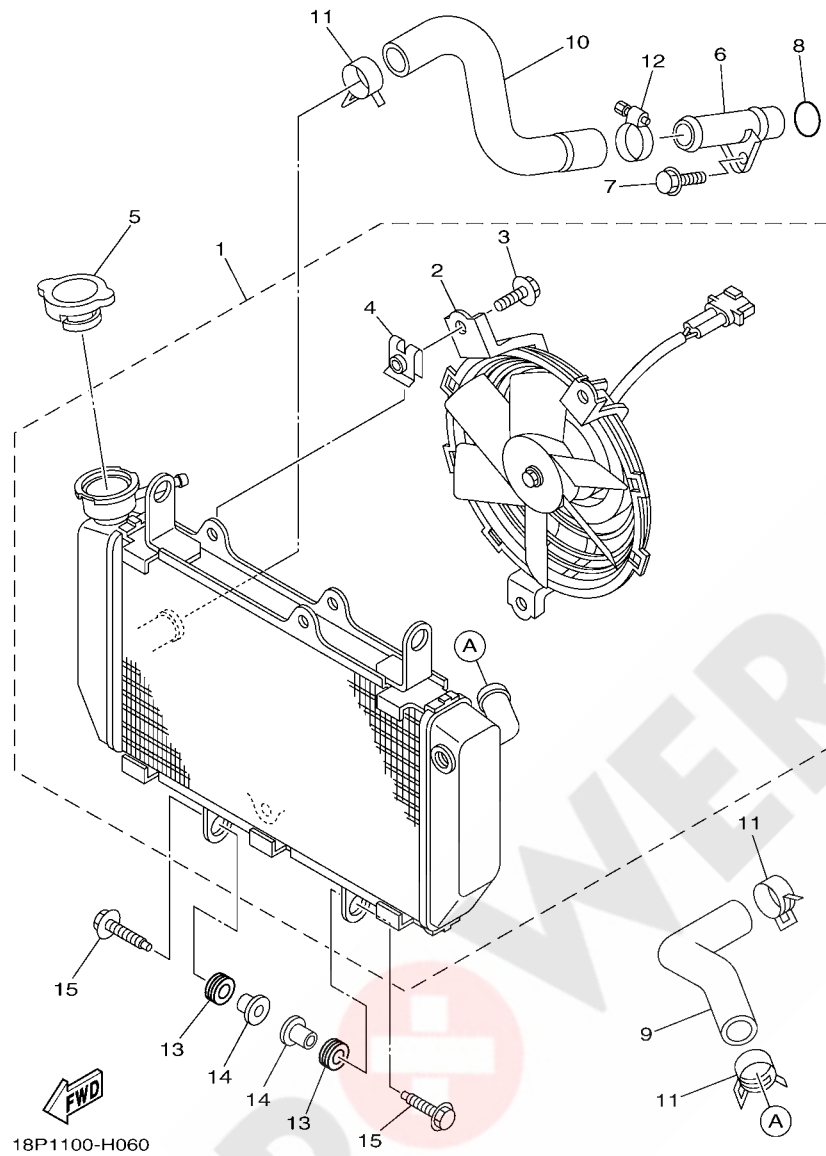
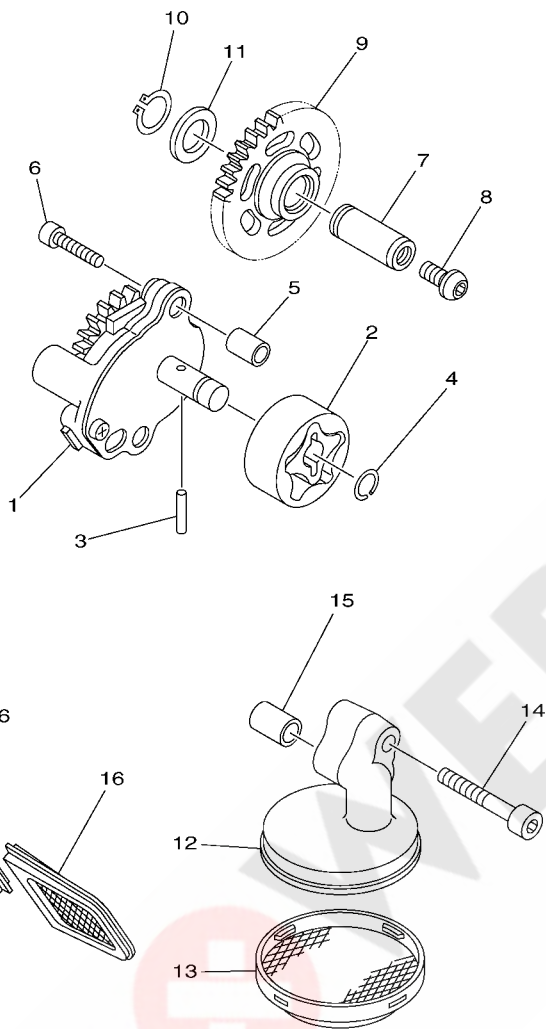


FIG. 6 RADIATOR & HOSE

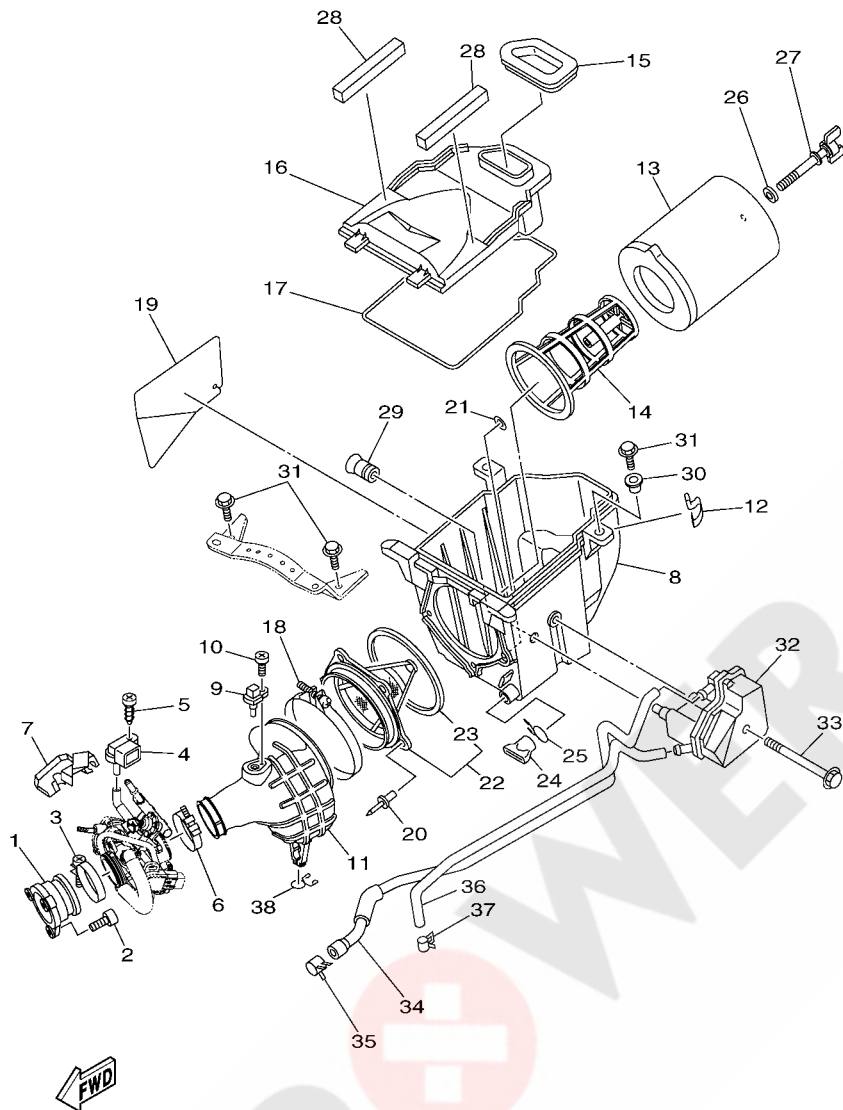
REF. NO.	PART NO.	DESCRIPTION	CAN	EUR	OCE	JPN	REMARKS
1	18P-1240A-00	RADIATOR ASSY	1	1	1	1	
2	18P-12405-00	.BLOWER ASSY	1	1	1	1	
3	2S3-12675-00	.BOLT, BLOWER HOLDING	3	3	3	3	
4	18P-12671-00	.NUT 1	3	3	3	3	
5	5SL-12462-00	CAP, RADIATOR	1	1	1	1	
6	5TG-12481-00	PIPE 1	1	1	1	1	
7	95022-06012	BOLT, FLANGE	1	1	1	1	
8	93210-16500	O-RING	1	1	1	1	
9	18P-12576-00	HOSE 1	1	1	1	1	
10	18P-12577-00	HOSE 2	1	1	1	1	
11	90467-23109	CLIP	3	3	3	3	
12	90450-32015	HOSE CLAMP ASSY	1	1	1	1	
13	90480-15058	GROMMET	4	4	4	4	
14	90387-07391	COLLAR	4	4	4	4	
15	90119-06181	BOLT, WITH WASHER	4	4	4	4	



  
 18P1100-H070

**FIG. 7 OIL PUMP**

REF. NO.	PART NO.	DESCRIPTION	CAN	EUR	OCE	JPN	REMARKS
1	18P-13300-00	OIL PUMP ASSY	1	1	1	1	
2	5TA-13320-00	ROTOR ASSY 2	1	1	1	1	
3	93603-16219	PIN, DOWEL	1	1	1	1	
4	93440-10153	CIRCLIP	1	1	1	1	
5	99530-08012	PIN, DOWEL	2	2	2	2	
6	91312-06030	BOLT	2	2	2	2	
7	2S2-13342-00	SHAFT, IDLE GEAR	1	1	1	1	
8	90149-06069	SCREW	1	1	1	1	
9	18P-13341-00	GEAR, OIL PUMP IDLE	1	1	1	1	
10	99009-12400	CIRCLIP	1	1	1	1	
11	90201-12166	WASHER, PLATE	1	1	1	1	
12	18P-13412-01	HOUSING, STRAINER	1	1	1	1	
13	18P-13411-00	STRAINER, OIL	1	1	1	1	
14	90110-06208	BOLT, HEXAGON SOCKET HEAD	1	1	1	1	
15	99530-10114	PIN, DOWEL	1	1	1	1	
16	18P-13421-00	STRAINER 2	2	2	2	2	

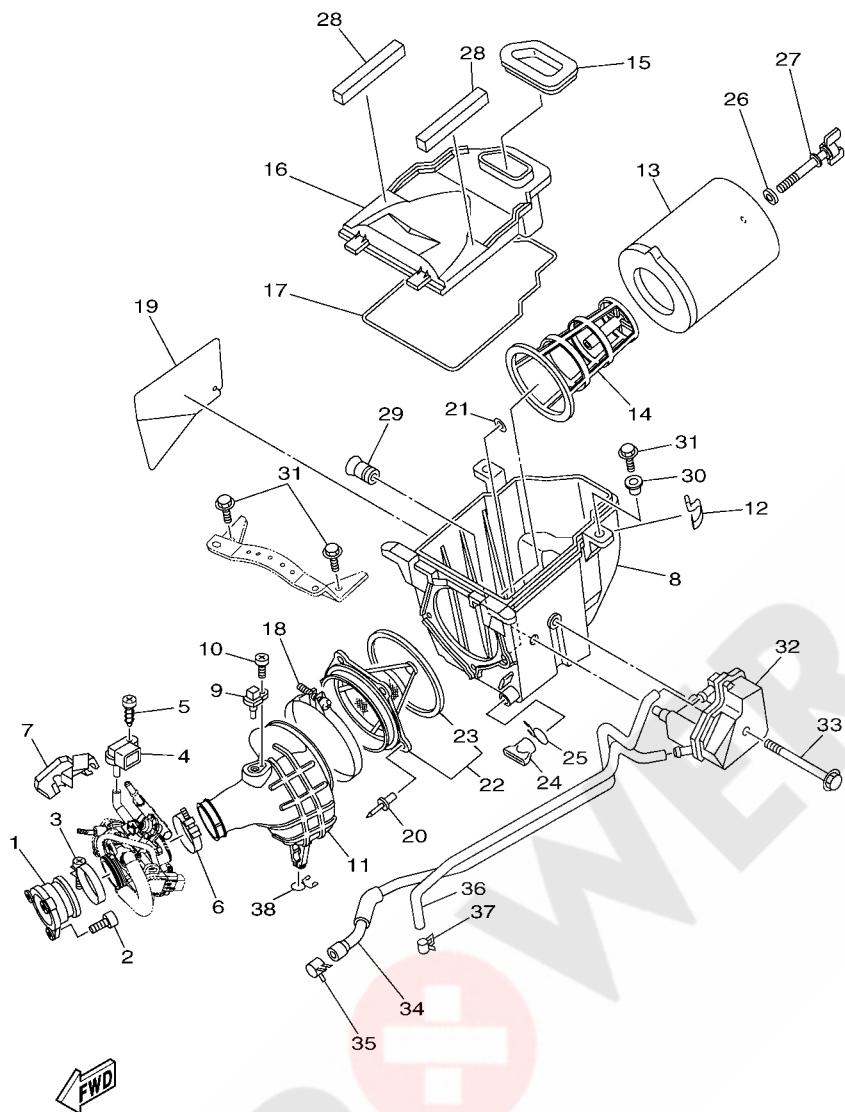


18P1100-H080

FIG. 8 INTAKE

REF. NO.	PART NO.	DESCRIPTION	CAN	EUR	OCE	JPN	REMARKS
1	18P-13597-00	JOINT, CARBURETOR 3	1	1	1	1	
2	91312-06020	BOLT	3	3	3	3	
3	90450-58005	HOSE CLAMP ASSY	1	1	1	1	
4	5S7-82380-00	SENSOR, PRESSURE	1	1	1	1	
5	97702-60125	SCREW, TAPPING	1	1	1	1	
6	90450-54009	HOSE CLAMP ASSY	1	1	1	1	
7	18P-13843-00	PLATE 1	1	1	1	1	
8	18P-14411-00	CASE, AIR CLEANER 1	1	1	1	1	
9	8FP-85886-00	SENSOR, AIR TEMPERATURE	1	1	1	1	
10	98502-05010	SCREW, PAN HEAD	1	1	1	1	
11	18P-14453-00	JOINT, AIR CLEANER 1	1	1	1	1	
12	5GH-14436-00	HOOK	2	2	2	2	
13	5TG-14451-00	ELEMENT, AIR CLEANER	1	1	1	1	
14	5TG-14458-00	GUIDE	1	1	1	1	
15	18P-14479-00	FUNNEL	1	1	1	1	
16	18P-14412-00	CAP, CLEANER CASE 1	1	1	1	1	
17	5KM-14452-00	SEAL	1	1	1	1	
18	90450-99014	HOSE CLAMP ASSY	1	1	1	1	
19	18P-1442F-00	PROTECTOR	1	1	1	1	
20	90267-48025	RIVET, BLIND	5	5	5	5	
21	90201-04028	WASHER, PLATE	5	5	5	5	
22	5D3-14459-00	HOLDER, GUIDE	1	1	1	1	
23	4ES-14462-00	.SEAL	1	1	1	1	
24	59V-14457-00	SEAL	1	1	1	1	
25	90467-220A1	CLIP	1	1	1	1	
26	90209-06096	WASHER	1	1	1	1	
27	90122-06010	BOLT, WING	1	1	1	1	





18P1100-H080

FIG. 8 INTAKE

REF. NO.	PART NO.	DESCRIPTION	CAN	EUR	OCE	JPN	REMARKS
28	18P-14409-00	DAMPER	2	2	2	2	
29	18P-14435-00	GROMMET	1	1	1	1	
30	90387-08073	COLLAR	2	2	2	2	
31	90105-06084	BOLT, FLANGE	4	4	4	4	
32	18P-15370-00	BREATHER ASSY	1	1	1	1	
33	95812-06110	BOLT, FLANGE	1	1	1	1	
34	18P-1531A-00	HOSE, BREATHER 1	1	1	1	1	
35	90467-140A6	CLIP	1	1	1	1	
36	18P-1532A-00	HOSE, BREATHER 2	1	1	1	1	
37	90467-140A6	CLIP	1	1	1	1	
38	90467-12052	CLIP	1	1	1	1	

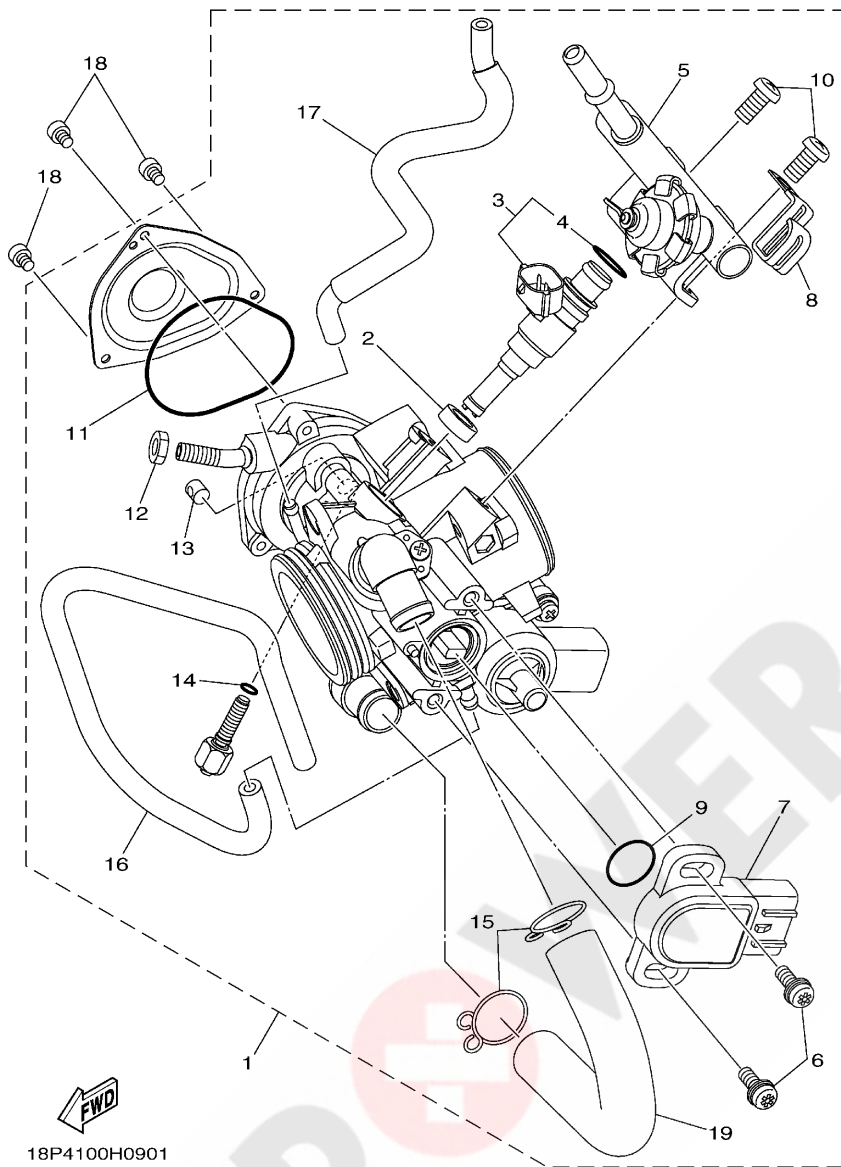


FIG. 9 THROTTLE BODY ASSY 1

REF. NO.	PART NO.	DESCRIPTION	CAN	EUR	OCE	JPN	REMARKS
1	18P-13750-00	THROTTLE BODY ASSY	1	1	1	1	
2	8FP-13556-00	.GASKET, MANIFOLD	1	1	1	1	
3	3B4-13761-00	.INJECTOR	1	1	1	1	
4	5PS-14147-00	.O-RING	1	1	1	1	
5	18P-13160-00	.DELIVERY PIPE ASSY 1	1	1	1	1	
6	8CC-14216-10	.SCREW	2	2	2	2	
7	3B4-85885-00	.THROTTLE SENSOR ASSY	1	1	1	1	
8	5JW-14945-00	.PLATE	1	1	1	1	
9	5YP-14562-00	.O-RING	1	1	1	1	
10	98507-06012	.SCREW, PAN HEAD	2	2	2	2	
11	5LP-14147-00	.O-RING	1	1	1	1	
12	1S3-14161-00	.NUT, CABLE ADJUSTING	1	1	1	1	
13	1UY-14155-00	.GUIDE, CABLE	1	1	1	1	
14	2H0-14147-00	.O-RING	1	1	1	1	
15	8FP-14137-00	.CLIP	2	2	2	2	
16	18P-13543-00	.HOSE, AIR	1	1	1	1	
17	18P-14348-00	.PIPE 1	1	1	1	1	
18	91312-04006	BOLT	3	3	3	3	
19	18P-13545-00	.HOSE	1	1	1	1	

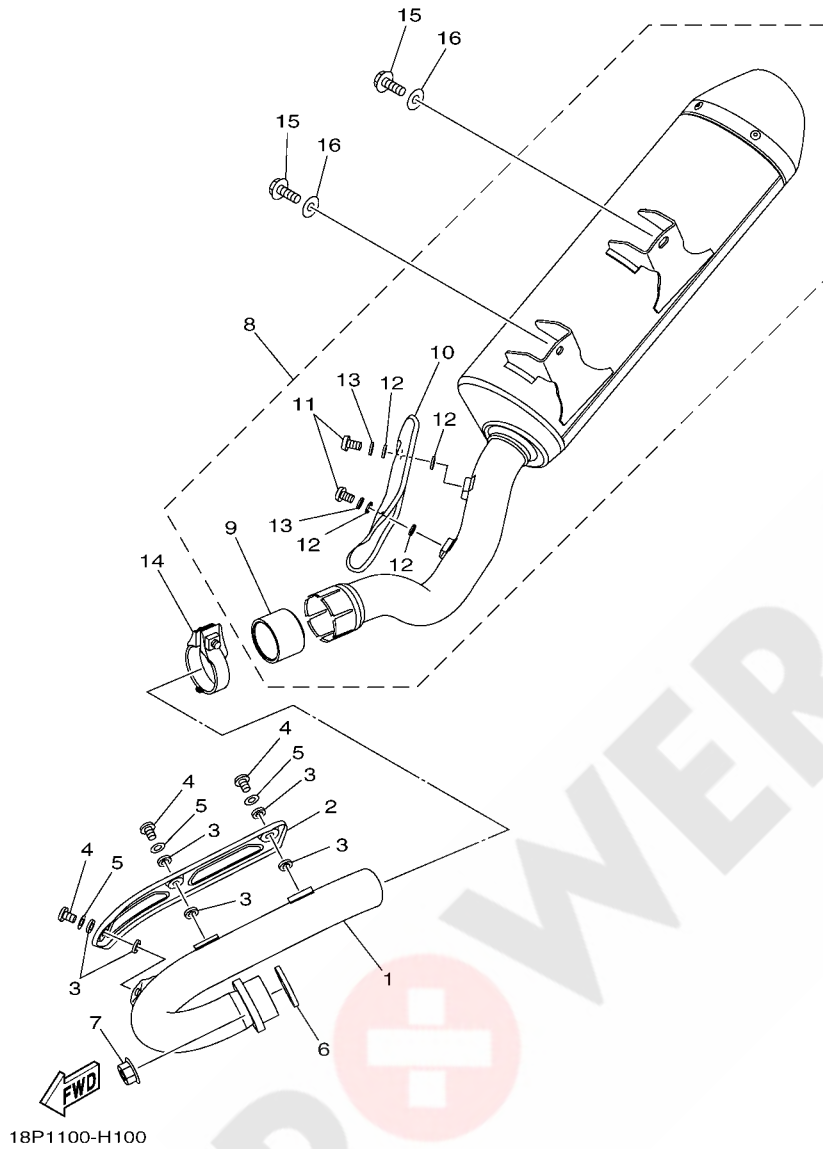
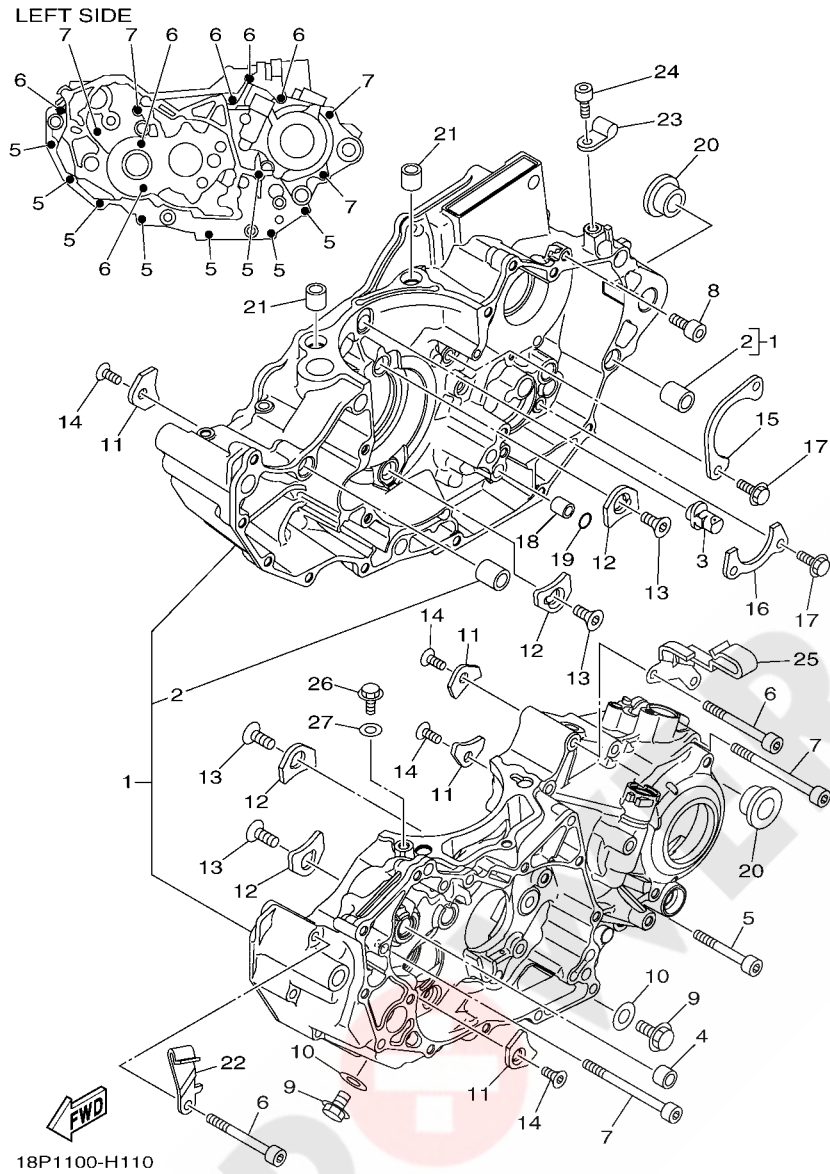


FIG. 10 EXHAUST

REF. NO.	PART NO.	DESCRIPTION	CAN	EUR	OCE	JPN	REMARKS
1	18P-14611-00	PIPE, EXHAUST 1	1	1	1	1	
2	18P-14628-00	PROTECTOR, EXHAUST PIPE	1	1	1	1	
3	90201-05015	WASHER, PLATE	6	6	6	6	
4	98980-06010	SCREW, BIND	3	3	3	3	
5	92990-06200	WASHER, PLAIN	3	3	3	3	
6	3VD-14613-01	GASKET, EXHAUST PIPE	1	1	1	1	
7	95702-08500	NUT, FLANGE	2	2	2	2	
8	18P-14710-00	MUFFLER ASSY 1	1	1	1	1	
9	8FA-14714-10	.GASKET, MUFFLER	1	1	1	1	
10	18P-14718-00	.PROTECTOR, MUFFLER 1	1	1	1	1	
11	98902-06010	.SCREW, BIND	2	2	2	2	
12	90201-05015	.WASHER, PLATE	4	4	4	4	
13	92902-06200	.WASHER	2	2	2	2	
14	5BE-14788-00	BAND, SILENCER	1	1	1	1	
15	90105-08129	BOLT, FLANGE	2	2	2	2	
16	90201-08048	WASHER, PLATE	2	2	2	2	



18P1100-H110

FIG. 11 CRANKCASE

REF. NO.	PART NO.	DESCRIPTION	CAN	EUR	OCE	JPN	REMARKS
1	18P-15100-00	CRANKCASE ASSY	1	1	1	1	
2	99530-14016	.PIN, DOWEL	2	2	2	2	
3	2S2-15155-10	NOZZLE 3	1	1	1	1	
4	90380-10002	BUSH, SOLID	1	1	1	1	
5	91312-06050	BOLT	8	8	8	8	
6	91312-06060	BOLT	6	6	6	6	
7	91312-06080	BOLT	4	4	4	4	
8	91312-06016	BOLT	1	1	1	1	
9	95022-10016	BOLT, FLANGE	2	2	2	2	
10	90430-10148	GASKET	2	2	2	2	
11	4JT-15381-01	PLATE, BEARING COVER	4	4	4	4	
12	18P-15383-00	PLATE, BEARING COVER	4	4	4	4	
13	90151-08003	SCREW, COUNTERSUNK	4	4	4	4	
14	90149-06074	SCREW	4	4	4	4	
15	2S2-15388-00	PLATE, BEARING COVER	1	1	1	1	
16	2S2-18562-00	PLATE, STOPPER 2	1	1	1	1	
17	90105-06081	BOLT, FLANGE	4	4	4	4	
18	99530-10114	PIN, DOWEL	1	1	1	1	
19	93210-10197	O-RING	1	1	1	1	
20	90387-164N2	COLLAR	2	2	2	2	
21	99530-14016	PIN, DOWEL	2	2	2	2	
22	90462-10056	CLAMP	1	1	1	1	
23	90461-10135	CLAMP	1	1	1	1	
24	91312-06016	BOLT	1	1	1	1	
25	18P-15378-00	HOLDER	1	1	1	1	
26	95022-06012	BOLT, FLANGE	1	1	1	1	
27	90430-06014	GASKET	1	1	1	1	

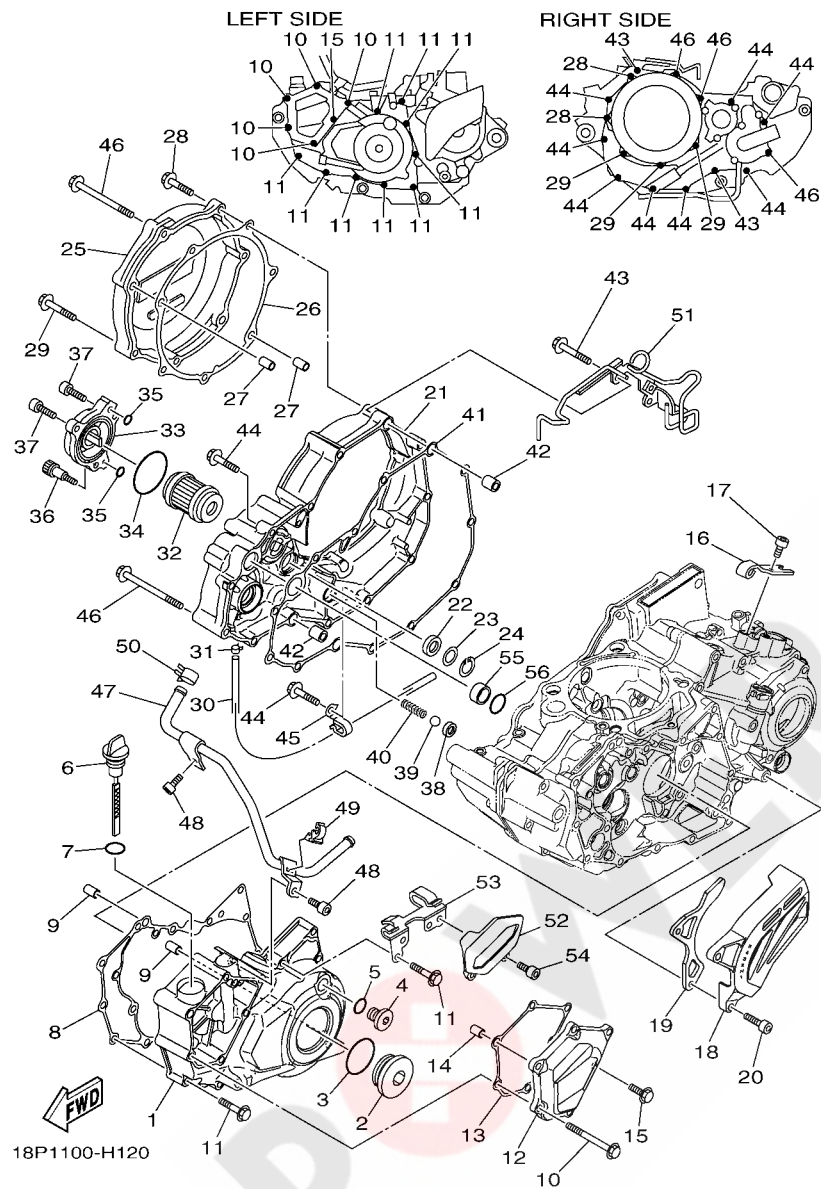


FIG. 12 CRANKCASE COVER 1

REF. NO.	PART NO.	DESCRIPTION	CAN	EUR	OCE	JPN	REMARKS
1	18P-15411-00	COVER, CRANKCASE 1	1	1	1	1	
2	90340-36002	PLUG, STRAIGHT SCREW	1	1	1	1	
3	93210-357A3	O-RING	1	1	1	1	
4	90340-14011	PLUG, STRAIGHT SCREW	1	1	1	1	
5	93210-14369	O-RING	1	1	1	1	
6	18P-15362-00	PLUG, OIL LEVEL	1	1	1	1	
7	93210-19026	O-RING	1	1	1	1	
8	18P-15451-00	GASKET, CRANKCASE COVER 1	1	1	1	1	
9	99530-08016	PIN, DOWEL	2	2	2	2	
10	95022-06065	BOLT, FLANGE	5	5	5	5	
11	95022-06035	BOLT, FLANGE	9	9	9	9	
12	18P-15423-00	COVER 2	1	1	1	1	
13	18P-15463-00	GASKET, COVER PINION 2	1	1	1	1	
14	99530-08012	PIN, DOWEL	1	1	1	1	
15	95022-06020	BOLT, FLANGE	1	1	1	1	
16	5TA-15441-01	HOLDER, CLUTCH CABLE	1	1	1	1	
17	91312-06016	BOLT	1	1	1	1	
18	18P-15421-00	COVER, CRANKCASE 2	1	1	1	1	
19	18P-17466-00	GUIDE, CHAIN	1	1	1	1	
20	91312-06025	BOLT	2	2	2	2	
21	18P-15431-00	COVER, CRANKCASE 3	1	1	1	1	
22	93101-14164	OIL SEAL	1	1	1	1	
23	90201-15701	WASHER, PLATE (T=1.0)	1	1	1	1	
24	99009-22500	CIRCLIP	1	1	1	1	
25	5TG-15415-00	COVER, GENERATOR	1	1	1	1	
26	18P-15453-00	GASKET	1	1	1	1	
27	99530-08016	PIN, DOWEL	2	2	2	2	

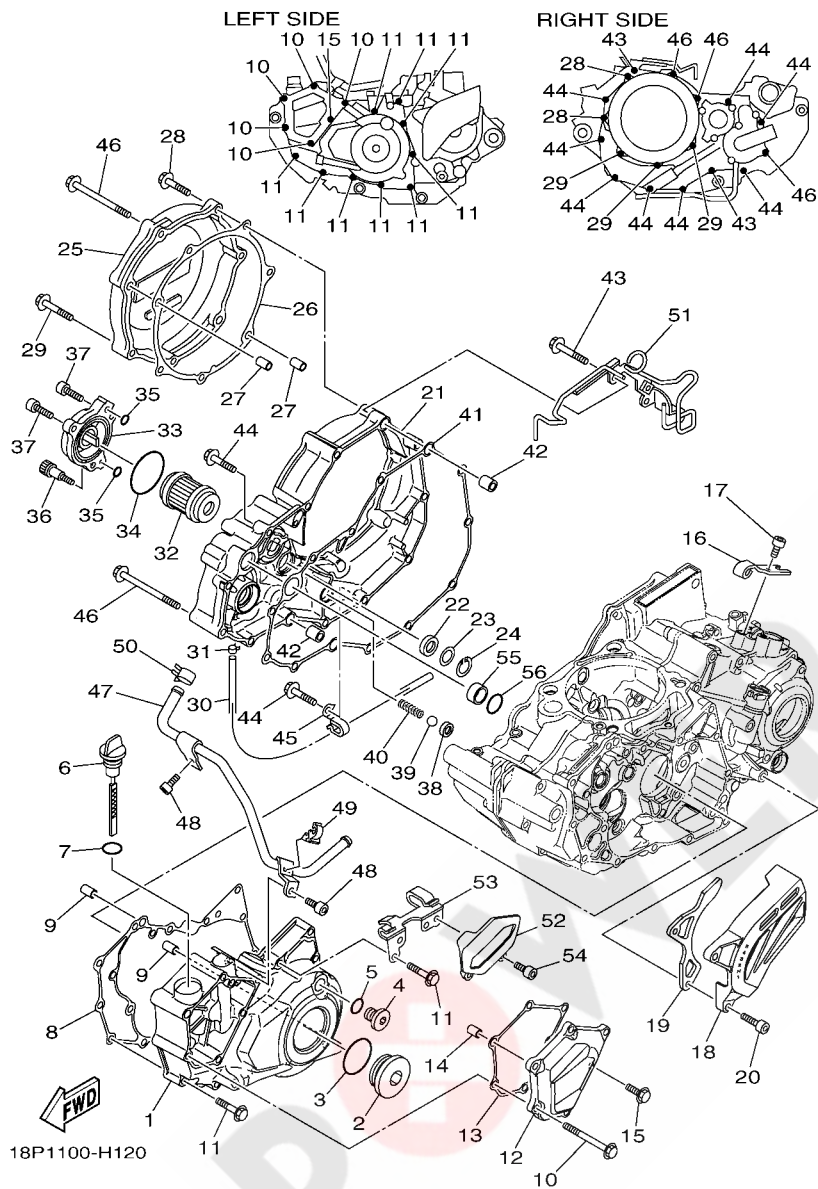


FIG. 12 CRANKCASE COVER 1

REF. NO.	PART NO.	DESCRIPTION	CAN	EUR	OCE	JPN	REMARKS
28	95022-06030	BOLT, FLANGE	2	2	2	2	
29	95022-06040	BOLT, FLANGE	3	3	3	3	
30	18P-1243A-00	HOSE 1	1	1	1	1	
31	90467-070A0	CLIP	1	1	1	1	
32	5D3-13440-00	ELEMENT ASSY, OIL CLEANER	1	1	1	1	
33	5BE-13447-10	COVER, OIL ELEMENT	1	1	1	1	
34	93210-47675	O-RING	1	1	1	1	
35	93210-07135	O-RING	3	3	3	3	
36	90110-06228	BOLT, HEXAGON SOCKET HEAD	1	1	1	1	
37	91312-06020	BOLT	2	2	2	2	
38	583-13113-00	SEAT, CHECK BALL	1	1	1	1	
39	93503-08007	BALL	1	1	1	1	
40	90501-043E0	SPRING, COMPRESSION	1	1	1	1	
41	18P-15462-00	GASKET, CRANKCASE COVER 3	1	1	1	1	
42	99530-10120	PIN, DOWEL	2	2	2	2	
43	95022-06040	BOLT, FLANGE	2	2	2	2	
44	95022-06030	BOLT, FLANGE	8	8	8	8	
45	90465-08127	CLAMP	1	1	1	1	
46	95022-06080	BOLT, FLANGE	3	3	3	3	
47	18P-15393-01	PIPE, BREATHER 2	1	1	1	1	
48	91312-06016	BOLT	2	2	2	2	
49	90464-08051	CLAMP	1	1	1	1	
50	90467-140A6	CLIP	1	1	1	1	
51	18P-15484-00	CLAMP 2	1	1	1	1	
52	18P-15413-00	COVER	1	1	1	1	
53	18P-1541A-00	STAY, CRANKCASE COVER 1	1	1	1	1	
54	91312-06016	BOLT	2	2	2	2	

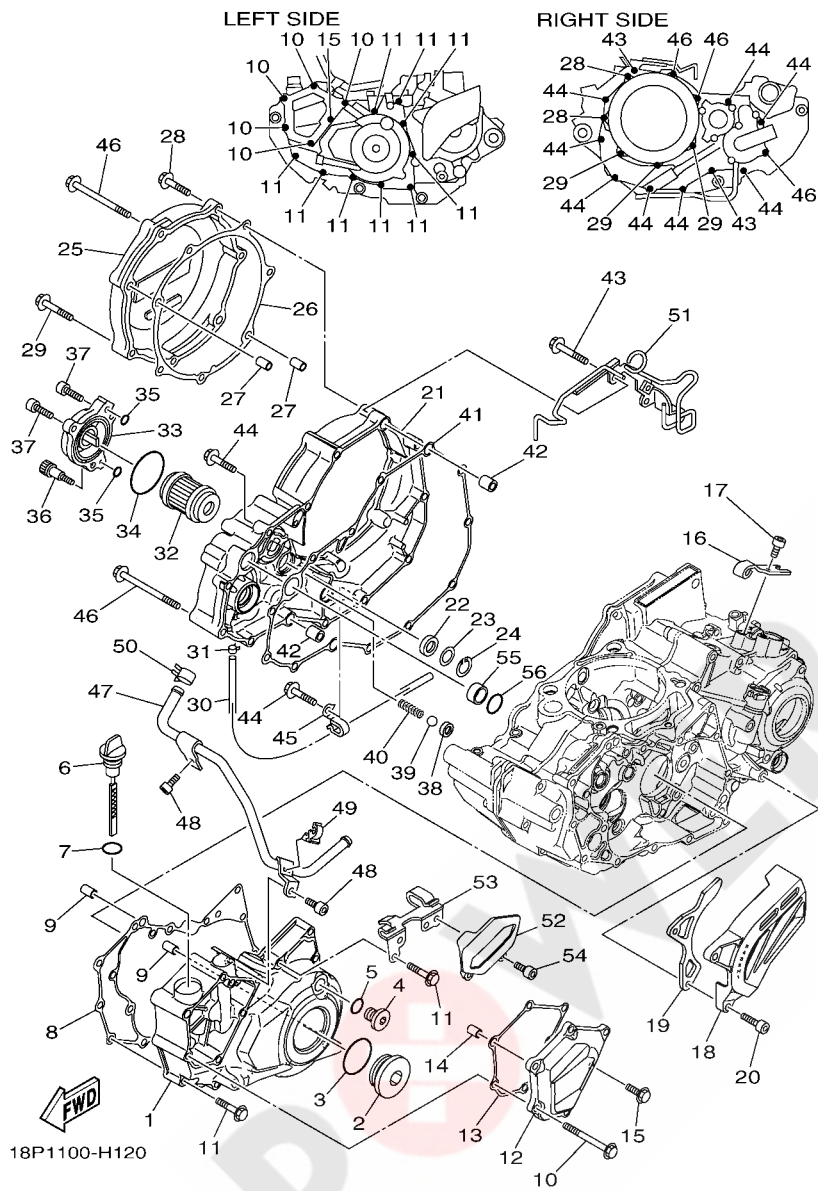
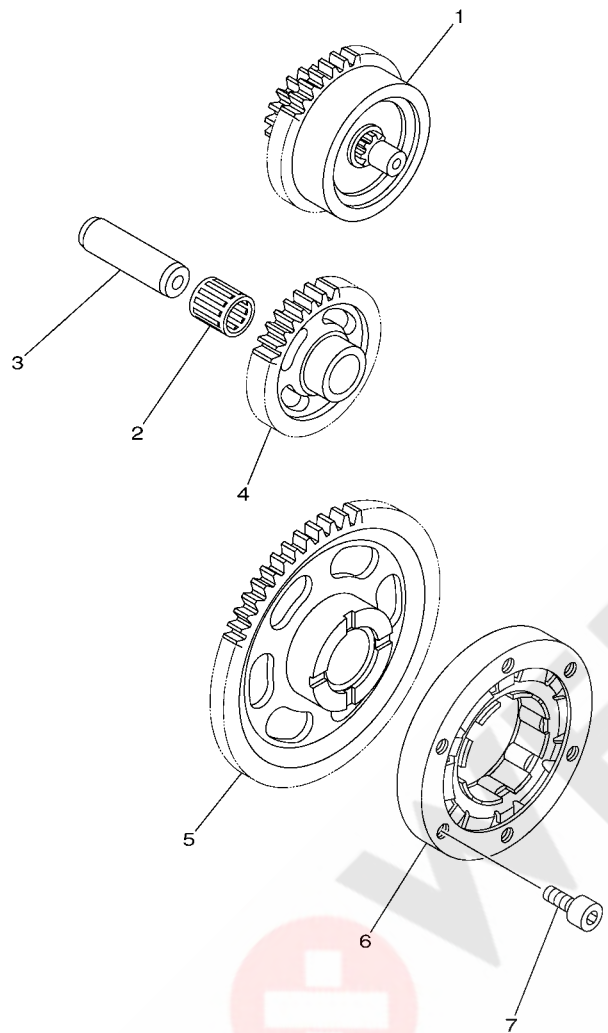


FIG. 12 CRANKCASE COVER 1

REF. NO.	PART NO.	DESCRIPTION	CAN	EUR	OCE	JPN	REMARKS
55	5BE-12564-00	PIPE, WATER	1	1	1	1	
56	93210-19758	O-RING	1	1	1	1	
-----							
-----							
-----							
-----							
-----							
-----							
-----							
-----							
-----							

FIG. 13 STARTER



 18P1100-H130

REF. NO.	PART NO.	DESCRIPTION	CAN	EUR	OCE	JPN	REMARKS
1	18P-15560-00	DAMPER ASSY	1	1	1	1	
2	93310-11268	BEARING	1	1	1	1	
3	18P-15521-00	SHAFT 1	1	1	1	1	
4	18P-15517-00	GEAR, IDLER 2	1	1	1	1	
5	18P-15515-00	GEAR 3	1	1	1	1	
6	5TJ-15590-00	STARTER ONE-WAY ASSY	1	1	1	1	
7	90110-06168	BOLT, HEXAGON SOCKET HEAD	6	6	6	6	



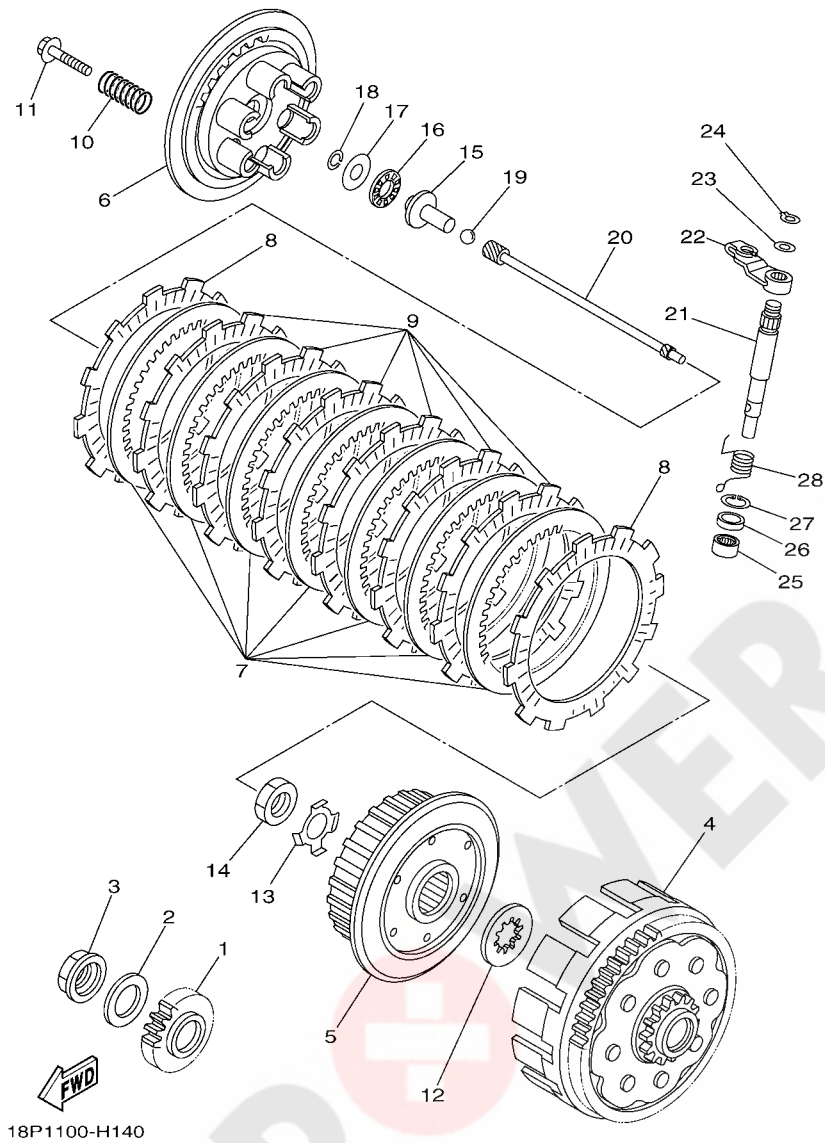


FIG. 14 CLUTCH

REF. NO.	PART NO.	DESCRIPTION	CAN	EUR	OCÉ	JPN	REMARKS
1	2S2-16111-60	GEAR, PRIMARY DRIVE	1	1	1	1	
2	90208-25045	WASHER, CONICAL SPRING	1	1	1	1	
3	90179-20009	NUT	1	1	1	1	
4	18P-16150-00	PRIMARY DRIVEN GEAR COMP.	1	1	1	1	
5	5TA-16371-10	BOSS, CLUTCH	1	1	1	1	
6	2S2-16351-00	PLATE, PRESSURE 1	1	1	1	1	
7	4X7-16325-00	PLATE, CLUTCH 2	7	7	7	7	
8	5TA-16321-00	PLATE, FRICTION	2	2	2	2	
9	5VY-16321-00	PLATE, FRICTION	6	6	6	6	
10	90501-231E9	SPRING, COMPRESSION	6	6	6	6	
11	90159-06010	SCREW, WITH WASHER	6	6	6	6	
12	5XD-16154-00	PLATE, THRUST 1	1	1	1	1	
13	90215-20005	WASHER, LOCK	1	1	1	1	
14	90170-20327	NUT	1	1	1	1	
15	5TG-16356-00	ROD, PUSH 1	1	1	1	1	
16	93340-21505	BEARING	1	1	1	1	
17	90201-125L6	WASHER, PLATE	1	1	1	1	
18	93440-10085	CIRCLIP	1	1	1	1	
19	93515-32029	BALL	1	1	1	1	
20	18P-16357-00	ROD, PUSH 2	1	1	1	1	
21	18P-16382-00	AXLE, PUSH LEVER	1	1	1	1	
22	18P-16342-00	LEVER, PUSH	1	1	1	1	
23	90201-10032	WASHER, PLATE	1	1	1	1	
24	99009-10400	CIRCLIP	1	1	1	1	
25	93317-11287	BEARING	1	1	1	1	
26	93102-12224	OIL SEAL	1	1	1	1	
27	99009-20500	CIRCLIP	1	1	1	1	

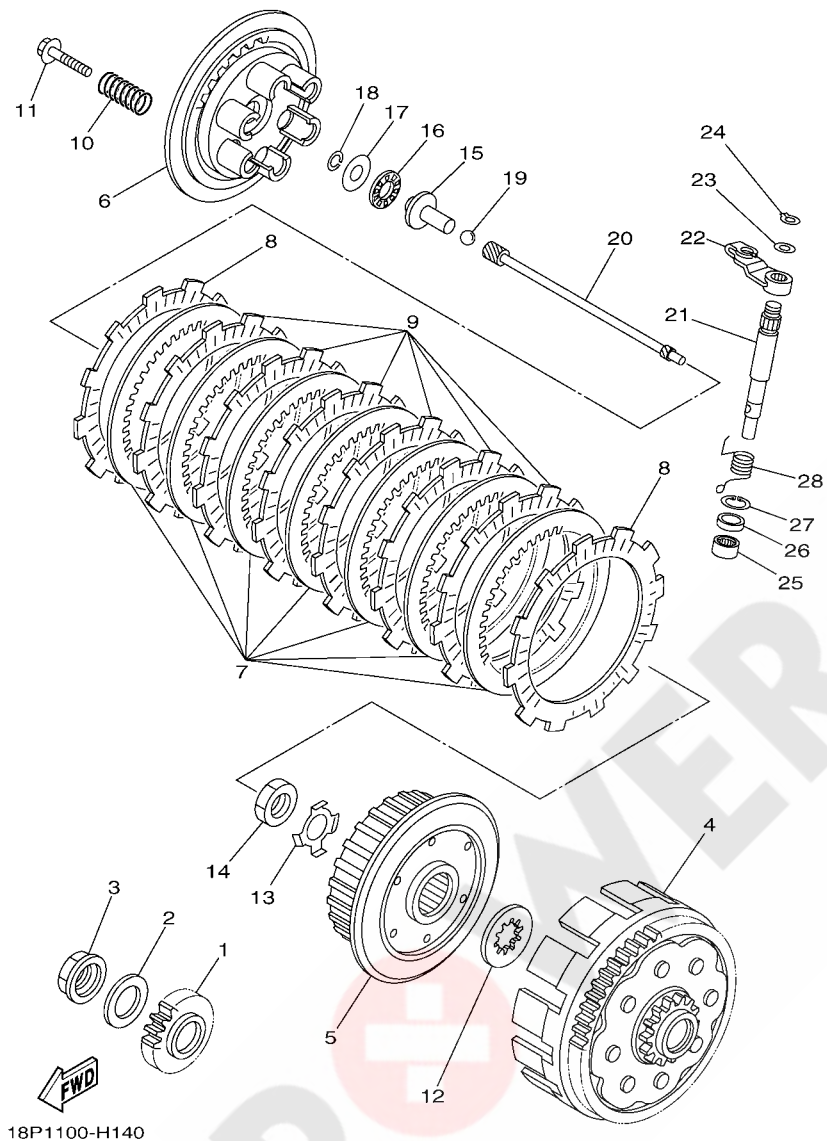
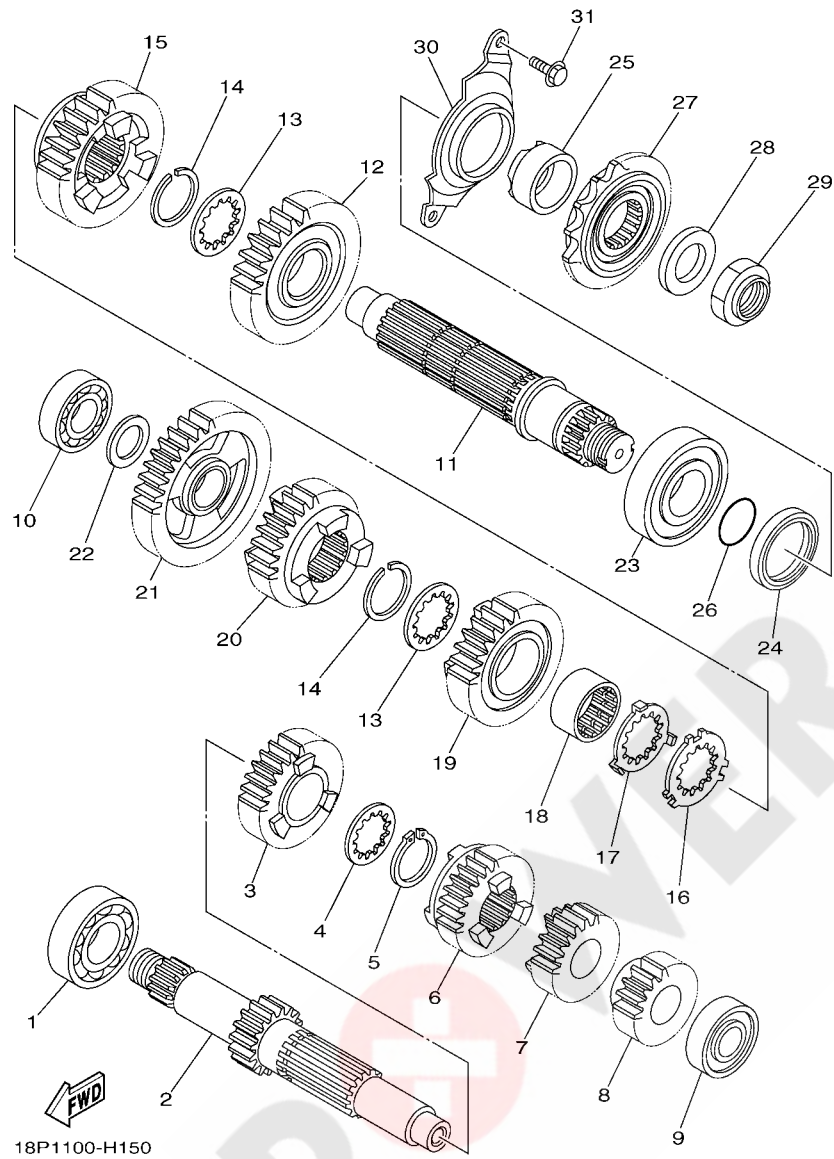


FIG. 14 CLUTCH

REF. NO.	PART NO.	DESCRIPTION	CAN	EUR	OCE	JPN	REMARKS
28	90508-16061	SPRING, TORSION	1	1	1	1	



18P1100-H150

FIG. 15 TRANSMISSION

REF. NO.	PART NO.	DESCRIPTION	CAN	EUR	OC	JPN	REMARKS
1	93306-20532	BEARING	1	1	1	1	
2	18P-17411-00	AXLE, MAIN	1	1	1	1	
3	18P-17151-00	GEAR, 5TH PINION (21T)	1	1	1	1	
4	90209-23012	WASHER	1	1	1	1	
5	93410-26067	CIRCLIP	1	1	1	1	
6	18P-17141-00	GEAR, 4TH PINION (21T)	1	1	1	1	
7	18P-17131-00	GEAR, 3RD PINION (19T)	1	1	1	1	
8	18P-17121-00	GEAR, 2ND PINION (15T)	1	1	1	1	
9	93306-20332	BEARING	1	1	1	1	
10	93306-00426	BEARING	1	1	1	1	
11	18P-17402-00	DRIVE AXLE ASSY	1	1	1	1	
12	18P-17221-00	GEAR, 2ND WHEEL (30T)	1	1	1	1	
13	90209-26008	WASHER	2	2	2	2	
14	93440-28062	CIRCLIP	2	2	2	2	
15	18P-17231-00	GEAR, 3RD WHEEL (31T)	1	1	1	1	
16	90214-26002	WASHER, CLAW	1	1	1	1	
17	90214-26003	WASHER, CLAW	1	1	1	1	
18	90387-26005	COLLAR	1	1	1	1	
19	18P-17241-00	GEAR, 4TH WHEEL (28T)	1	1	1	1	
20	18P-17251-00	GEAR, 5TH WHEEL (23T)	1	1	1	1	
21	18P-17211-00	GEAR, 1ST WHEEL (35T)	1	1	1	1	
22	90201-20276	WASHER, PLATE (T=1.0)	1	1	1	1	
23	93306-27803	BEARING	1	1	1	1	
24	93102-35393	OIL SEAL	1	1	1	1	
25	90387-28009	COLLAR	1	1	1	1	
26	93210-25001	O-RING	1	1	1	1	
27	18P-17460-00	SPROCKET, DRIVE (14T)	1	1	1	1	

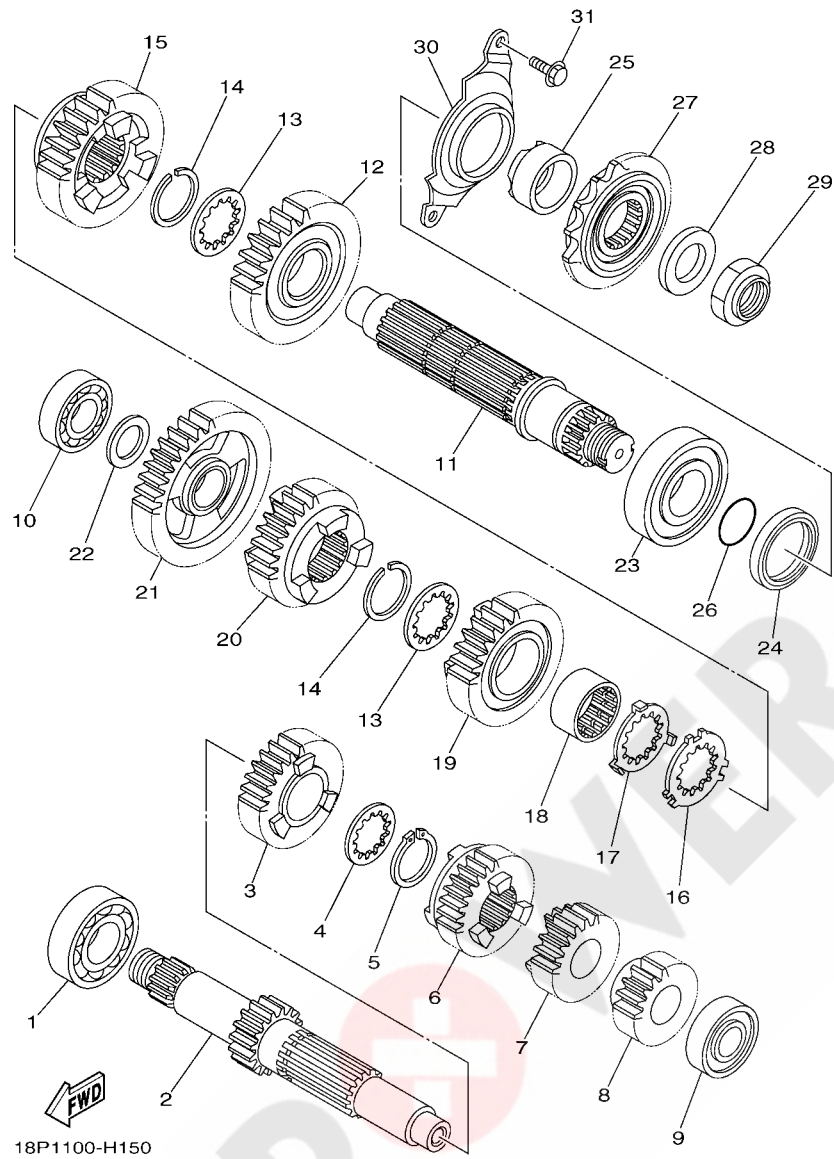
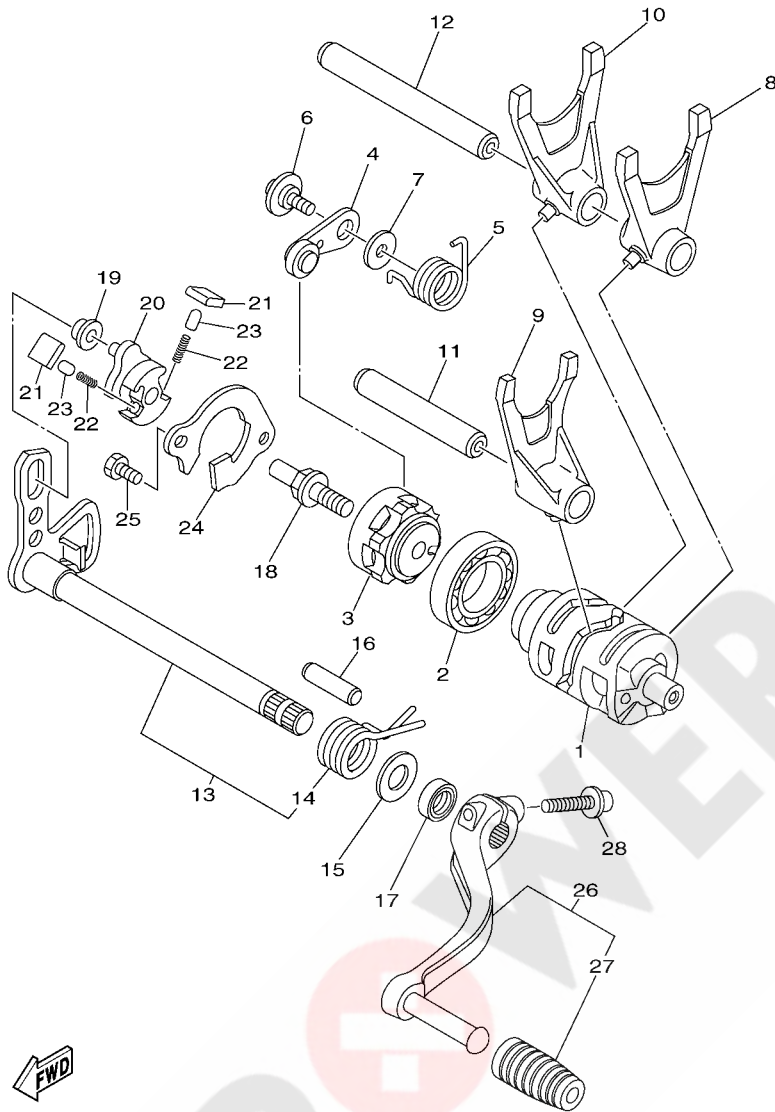


FIG. 15 TRANSMISSION

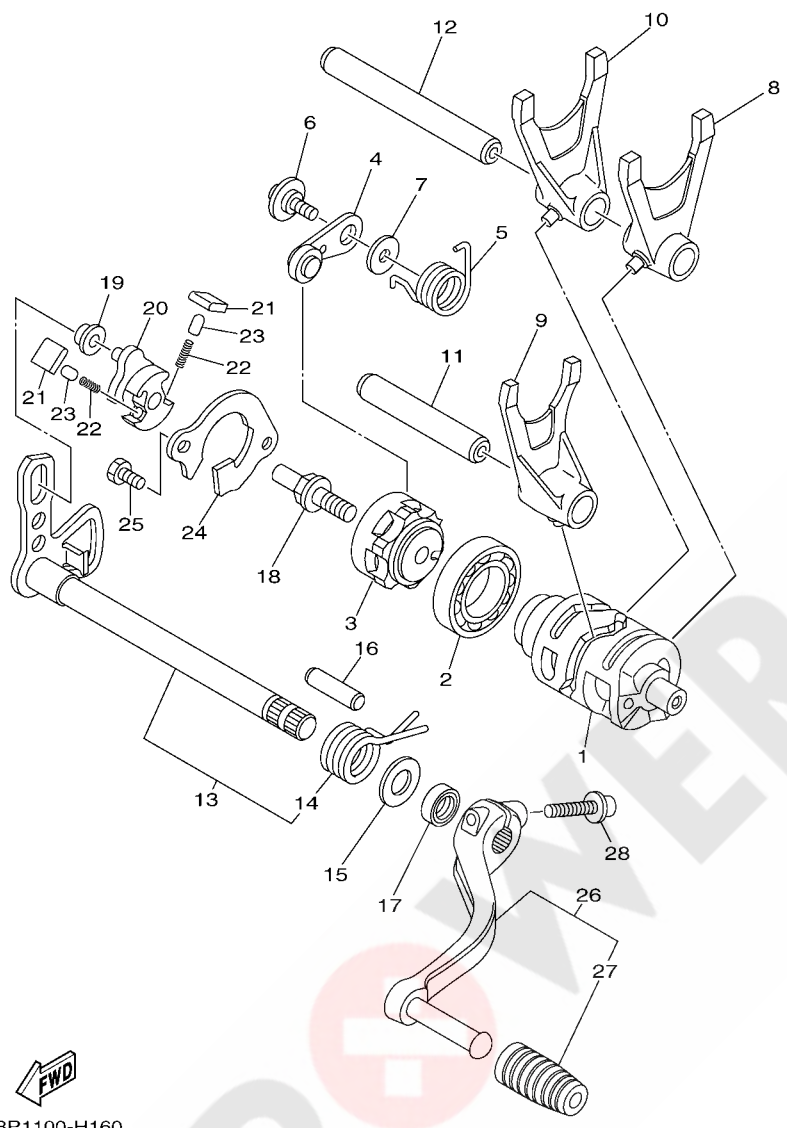
REF. NO.	PART NO.	DESCRIPTION	CAN	EUR	OCE	JPN	REMARKS
28	90201-22015	WASHER, PLATE	1	1	1	1	
29	90179-22018	NUT	1	1	1	1	
30	1S3-17471-00	PLATE, COVER	1	1	1	1	
31	95022-06014	BOLT, FLANGE	2	2	2	2	



18P1100-H160

FIG. 16 SHIFT CAM & FORK

REF. NO.	PART NO.	DESCRIPTION	CAN	EUR	OC	JPN	REMARKS
1	18P-18541-00	CAM, SHIFT	1	1	1	1	
2	93306-90509	BEARING	1	1	1	1	
3	2S2-18185-00	SEGMENT	1	1	1	1	
4	2S2-18140-10	STOPPER LEVER ASSY	1	1	1	1	
5	90508-26021	SPRING, TORSION	1	1	1	1	
6	90109-06198	BOLT	1	1	1	1	
7	90201-06013	WASHER, PLATE	1	1	1	1	
8	18P-18511-00	FORK, SHIFT 1	1	1	1	1	
9	18P-18512-00	FORK, SHIFT 2	1	1	1	1	
10	18P-18513-00	FORK, SHIFT 3	1	1	1	1	
11	18P-18531-00	BAR, SHIFT FORK GUIDE 1	1	1	1	1	
12	1WG-18531-01	BAR, SHIFT FORK GUIDE 1	1	1	1	1	
13	18P-18101-00	SHIFT SHAFT ASSY	1	1	1	1	
14	90508-32136	.SPRING, TORSION	1	1	1	1	
15	90201-127E1	WASHER, PLATE	1	1	1	1	
16	93608-30002	PIN, DOWEL	1	1	1	1	
17	93102-12224	OIL SEAL	1	1	1	1	
18	3XJ-18173-10	PIN, SHIFT	1	1	1	1	
19	3XJ-18178-00	ROLLER, SHIFT LEVER	1	1	1	1	
20	18P-18122-00	LEVER, SHIFT 2	1	1	1	1	
21	3XJ-18182-00	PAWL, SHIFTER	2	2	2	2	
22	90501-052G5	SPRING, COMPRESSION	2	2	2	2	
23	3XJ-18184-00	PIN, PAWL	2	2	2	2	
24	5BE-18172-00	GUIDE, SHIFT	1	1	1	1	
25	90101-06041	BOLT	2	2	2	2	
26	18P-18110-00	SHIFT PEDAL ASSY	1	1	1	1	
27	5YT-18113-00	.COVER, SHIFT PEDAL	1	1	1	1	

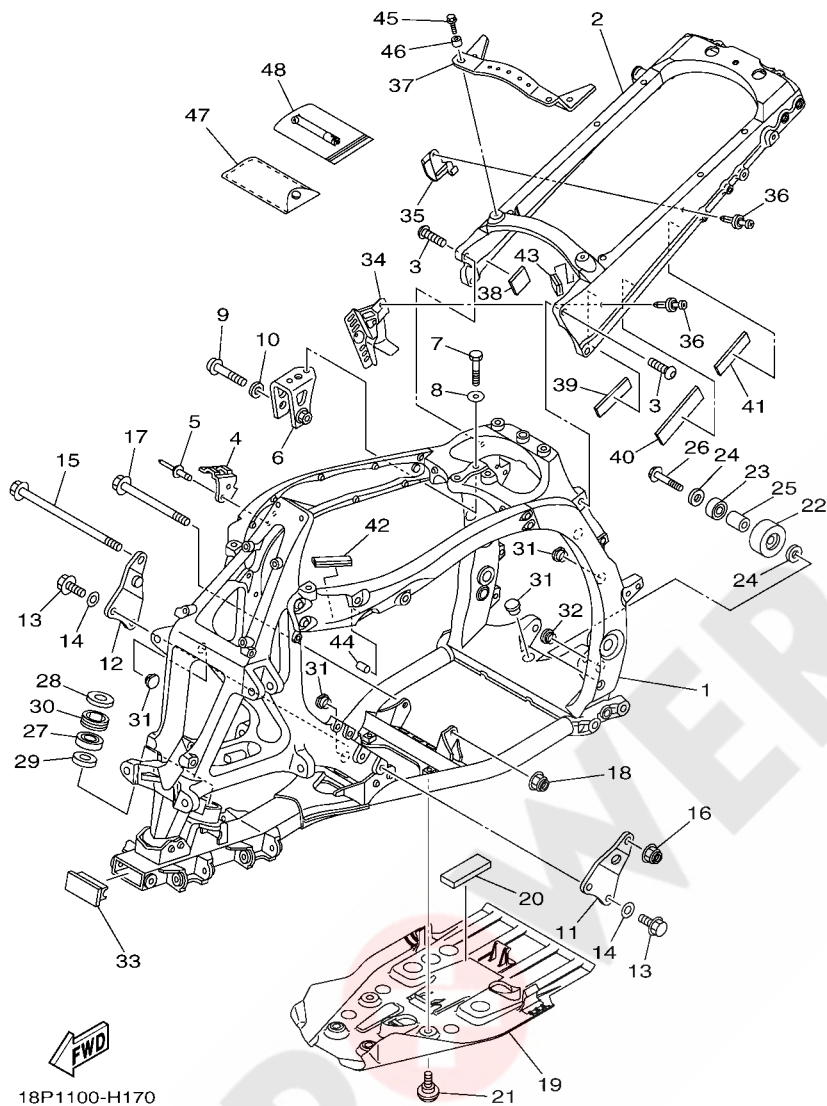


18P1100-H160

FIG. 16 SHIFT CAM & FORK

REF. NO.	PART NO.	DESCRIPTION	CAN	EUR	OCE	JPN	REMARKS
28	90109-06031	BOLT	1	1	1	1	

FIG. 17 FRAME



REF. NO.	PART NO.	DESCRIPTION	CAN	EUR	OC	JPN	REMARKS
1	18P-21101-09	FRONT FRAME COMP.	1	1	1	1	
2	18P-21190-09	REAR FRAME COMP.	1	1	1	1	
3	90149-10034	SCREW	4	4	4	4	
4	18P-2133H-00	BRKT., BRAKE PIPE 1	1	1	1	1	
5	90267-48176	RIVET, BLIND (4.8X17 YELLOW)	2	2	2	2	
6	18P-21315-00	STAY, ENGINE 1	1	1	1	1	
7	97012-08035	BOLT	2	2	2	2	
8	90201-08053	WASHER, PLATE	2	2	2	2	
9	90110-10029	BOLT, HEXAGON SOCKET HEAD	1	1	1	1	
10	90201-10036	WASHER, PLATE	1	1	1	1	
11	18P-21316-00	STAY, ENGINE 2	1	1	1	1	
12	18P-21317-00	STAY, ENGINE 3	1	1	1	1	
13	95812-10030	BOLT, FLANGE	4	4	4	4	
14	90201-10043	WASHER, PLATE	4	4	4	4	
15	90105-10350	BOLT, FLANGE	1	1	1	1	
16	90185-10011	NUT, SELF-LOCKING	1	1	1	1	
17	90105-10148	BOLT, FLANGE	1	1	1	1	
18	90185-10011	NUT, SELF-LOCKING	1	1	1	1	
19	18P-21471-00	PROTECTOR, ENGINE	1	1	1	1	
20	41R-21717-00	DAMPER	1	1	1	1	
21	90109-06198	BOLT	4	4	4	4	
22	5TG-22178-00	TENSIONER	1	1	1	1	
23	93300-60804	BEARING	1	1	1	1	
24	90201-08043	WASHER, PLATE	2	2	2	2	
25	90387-086N4	COLLAR	1	1	1	1	
26	90105-08112	BOLT, FLANGE	1	1	1	1	
27	93306-20352	BEARING	1	1	1	1	

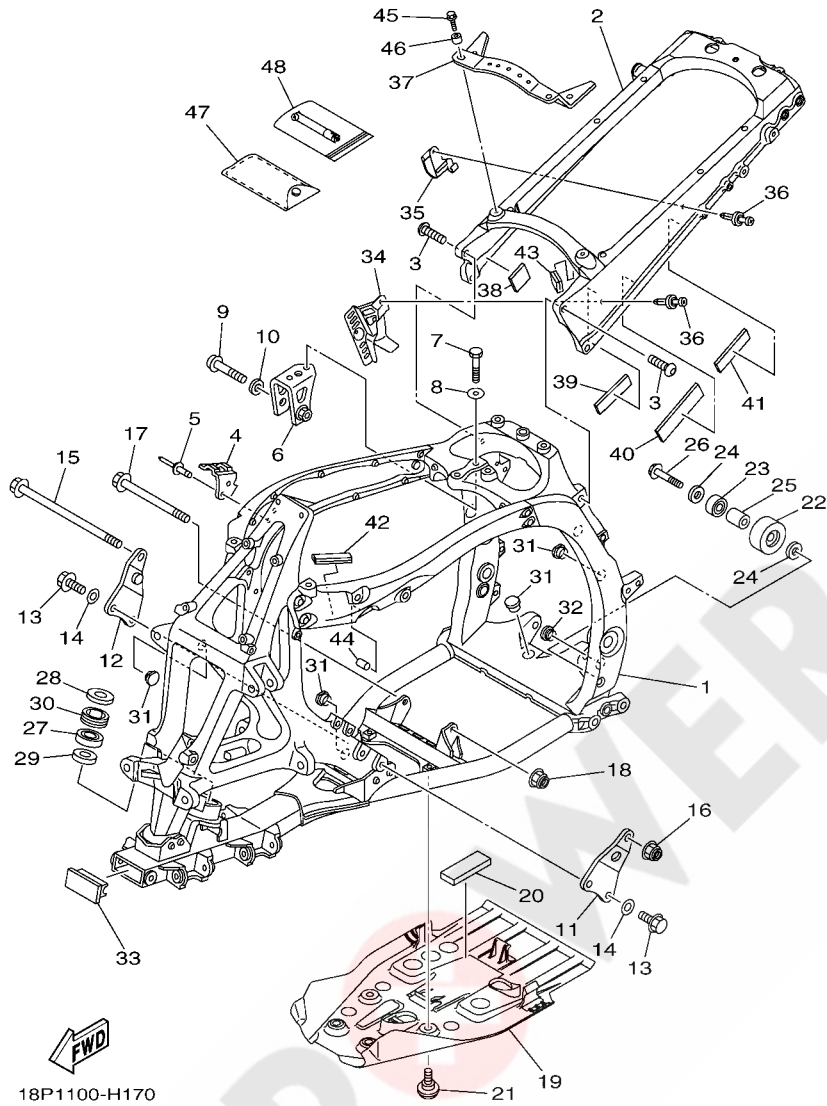


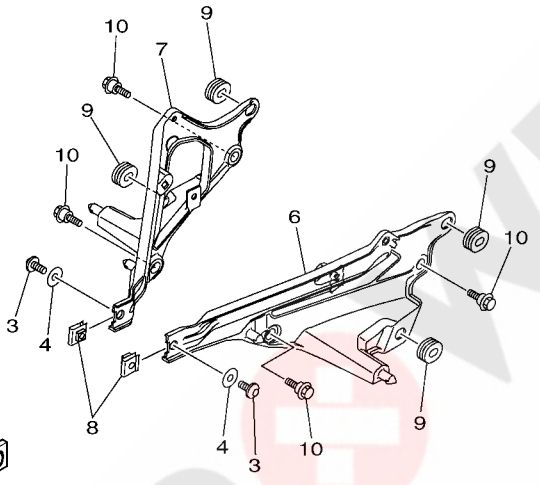
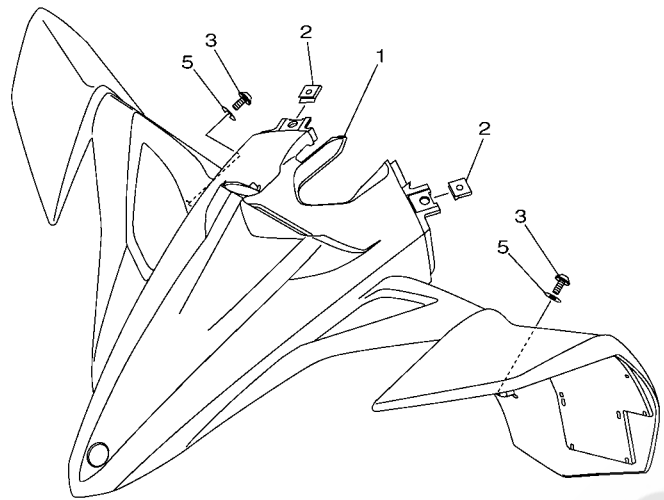
FIG. 17 FRAME

REF. NO.	PART NO.	DESCRIPTION	CAN	EUR	OCE	JPN	REMARKS
28	93102-25081	OIL SEAL	1	1	1	1	
29	93102-25099	OIL SEAL	1	1	1	1	
30	5GT-23872-00	HOLDER, BEARING	1	1	1	1	
31	90338-20183	PLUG	10	10	10	10	
32	90338-16007	PLUG	1	1	1	1	
33	18P-2111A-00	CAP, MAIN PIPE	1	1	1	1	
34	18P-21335-00	CLAMP, WIRE HARNESS 1	1	1	1	1	
35	18P-21336-00	CLAMP, WIRE HARNESS 2	1	1	1	1	
36	90269-05001	RIVET	2	2	2	2	
37	18P-21131-00	REINF., SEAT RAIL	1	1	1	1	
38	3KJ-24723-00	DAMPER, SEAT	1	1	1	1	
39	4XY-21638-00	DAMPER 1	1	1	1	1	
40	2S2-2177M-00	DAMPER, LOCATING 3	1	1	1	1	
41	1C3-2214F-00	DAMPER 1	1	1	1	1	
42	4XY-28347-00	MOLE 3	1	1	1	1	
43	3YX-2171L-00	MOLE, SIDE COVER 1	1	1	1	1	
44	90445-11418	HOSE (L18)	1	1	1	1	
45	90105-06084	BOLT, FLANGE	2	2	2	2	
46	90387-06197	COLLAR	2	2	2	2	
47	18P-28100-00	TOOL KIT	1	1	1	1	
48	1NV-2811A-01	GAUGE, AIR	1	1	1	1	

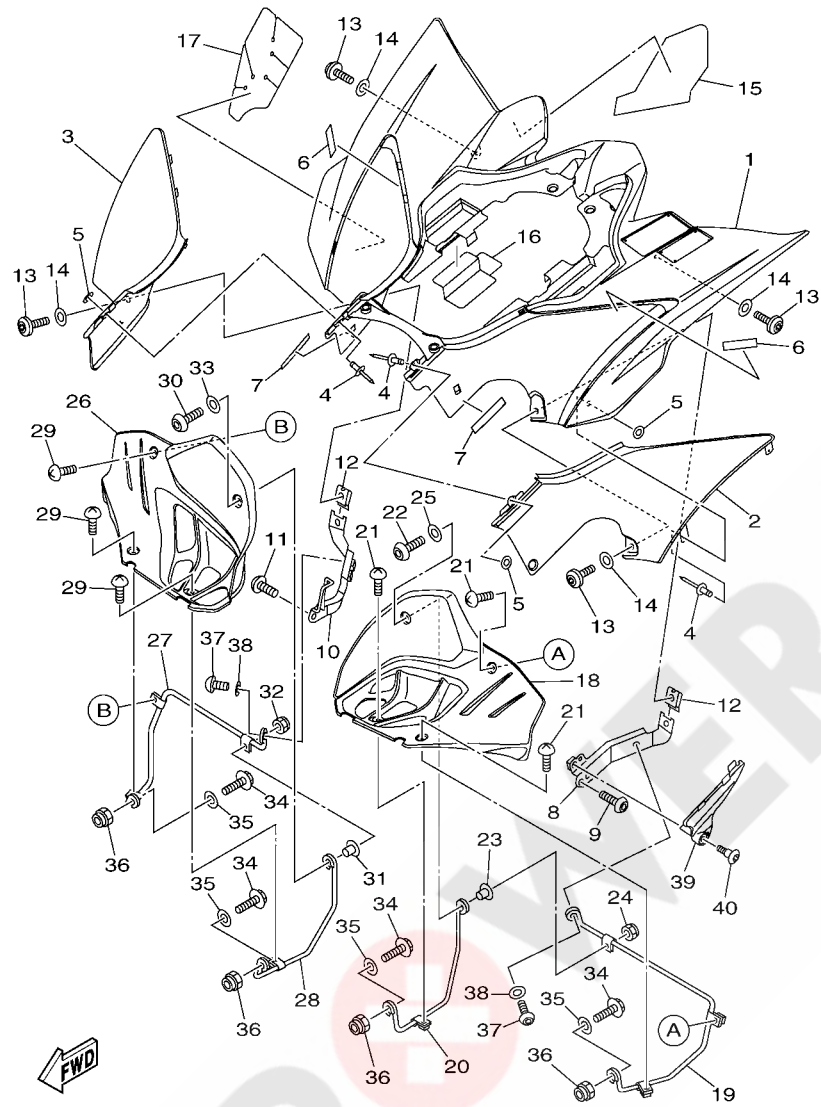


FIG. 18 FRONT FENDER

REF. NO.	PART NO.	DESCRIPTION	CAN	EUR	OCE	JPN	REMARKS
1	18P-W215C-00	FRONT FENDER COMP.2	1				UR FOR DPBSE
	18P-W215C-10	FRONT FENDER COMP.2	1				UR FOR BWS1
	18P-W215B-01	FRONT FENDER COMP. 2		1			UR FOR DPBSE
	18P-W215B-11	FRONT FENDER COMP. 2		1			UR FOR BWS1
	18P-W215D-00	FRONT FENDER COMP. 2			1	1	UR FOR DPBSE
	18P-W215D-10	FRONT FENDER COMP. 2			1		UR FOR BWS1
2	90183-061A5	NUT, SPRING	2	2	2	2	
3	90111-06038	BOLT,HEX. SOCKET BUTTON	4	4	4	4	
4	90201-06033	WASHER, PLATE	2	2	2	2	
5	90201-06085	WASHER, PLATE	2	2	2	2	
6	18P-21513-00	STAY, FENDER 1	1	1	1	1	
7	18P-21514-00	STAY, FENDER 2	1	1	1	1	
8	90183-061A5	NUT, SPRING	2	2	2	2	
9	90480-01559	GROMMET	4	4	4	4	
10	90109-06199	BOLT	4	4	4	4	



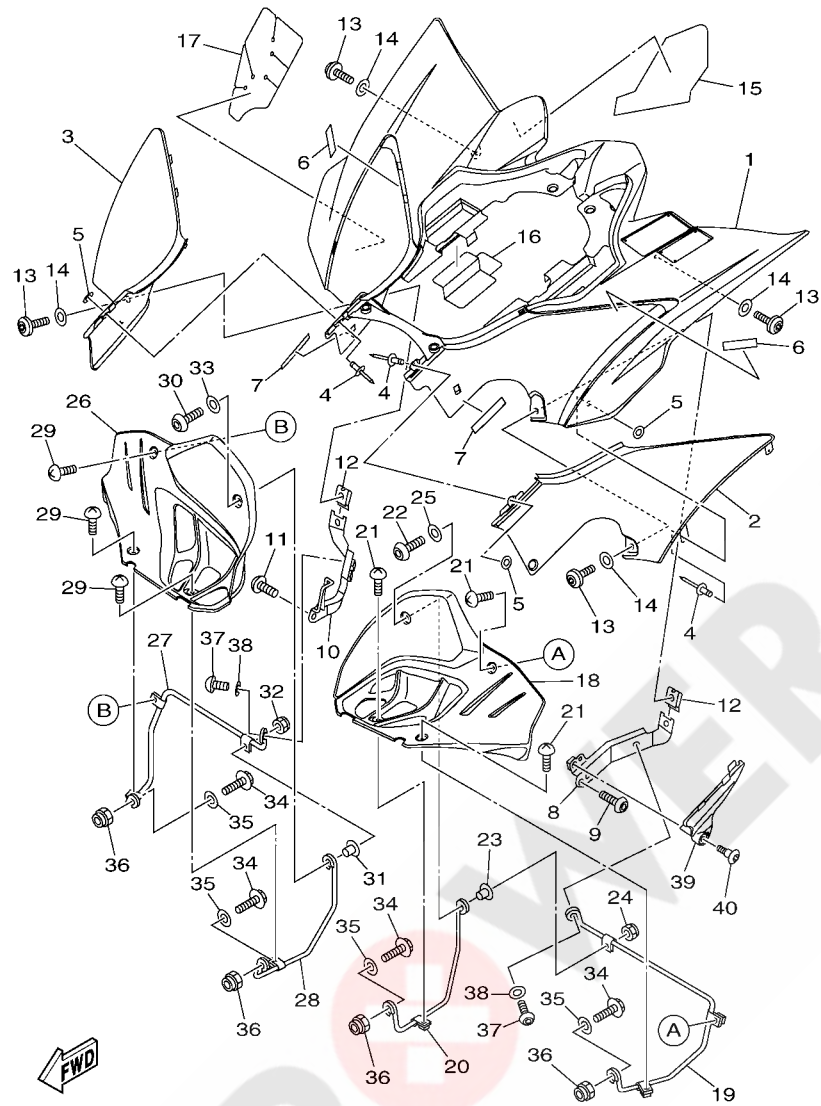
**FWD**  
18P1100-H180



18P1100-H190

FIG. 19 REAR FENDER

REF. NO.	PART NO.	DESCRIPTION	CAN	EUR	OCÉ	JPN	REMARKS
1	18P-W216C-00	REAR FENDER COMP.2	1				UR FOR DPBSE
	18P-W216C-10	REAR FENDER COMP.2	1				UR FOR BWS1
	18P-W216B-01	REAR FENDER COMP.2		1			UR FOR DPBSE
	18P-W216B-11	REAR FENDER COMP.2		1			UR FOR BWS1
	18P-W216D-00	REAR FENDER COMP			1	1	UR FOR DPBSE
	18P-W216D-10	REAR FENDER COMP			1		UR FOR BWS1
2	18P-2476U-00	PROTECTOR,1	1	1	1	1	
3	18P-2476V-00	PROTECTOR,2	1	1	1	1	
4	90267-32004	RIVET, BLIND	6	6	6	6	
5	90201-03008	WASHER, PLATE	6	6	6	6	
6	18P-2173U-00	TAPE 2	2	2	2	2	
7	18P-2173T-00	TAPE 1	2	2	2	2	
8	18P-21643-00	STAY, FENDER 3	1	1	1	1	
9	92012-08016	BOLT, BUTTON HEAD	2	2	2	2	
10	18P-21644-00	STAY, FENDER 4	1	1	1	1	
11	92012-08016	BOLT, BUTTON HEAD	1	1	1	1	
12	90183-061A5	NUT, SPRING	2	2	2	2	
13	90111-06038	BOLT,HEX. SOCKET BUTTON	4	4	4	4	
14	90201-06085	WASHER, PLATE	4	4	4	4	
15	18P-21652-00	PROTECTOR	1	1	1	1	
16	18P-2163E-00	COVER, 2	1	1	1	1	
17	18P-2163F-00	COVER, 3	1	1	1	1	
18	18P-21621-00	FLAP	1	1	1	1	
19	18P-2164F-00	STAY 1	1	1	1	1	
20	18P-2164H-00	STAY 3	1	1	1	1	
21	90154-05013	SCREW, BINDING	3	3	3	3	
22	92012-06030	BOLT, BUTTON HEAD	1	1	1	1	



18P1100-H190

FIG. 19 REAR FENDER

REF. NO.	PART NO.	DESCRIPTION	CAN	EUR	OC	JPN	REMARKS
23	90387-06205	COLLAR	1	1	1	1	
24	95602-06200	NUT, SELF-LOCKING	1	1	1	1	
25	90201-06076	WASHER, PLATE	1	1	1	1	
26	18P-21691-00	FLAP	1	1	1	1	
27	18P-2164G-00	STAY 2	1	1	1	1	
28	18P-2164J-00	STAY 4	1	1	1	1	
29	90154-05013	SCREW, BINDING	3	3	3	3	
30	92012-06030	BOLT, BUTTON HEAD	1	1	1	1	
31	90387-06205	COLLAR	1	1	1	1	
32	95602-06200	NUT, SELF-LOCKING	1	1	1	1	
33	90201-06076	WASHER, PLATE	1	1	1	1	
34	95822-08025	BOLT, FLANGE	4	4	4	4	
35	90201-08048	WASHER, PLATE	4	4	4	4	
36	95602-08200	NUT, SELF-LOCKING	4	4	4	4	
37	92012-08020	BOLT, BUTTON HEAD	2	2	2	2	
38	90201-08043	WASHER, PLATE	2	2	2	2	
39	18P-2163A-00	COVER, REAR FENDER 1	1	1	1	1	
40	90109-06249	BOLT	1	1	1	1	

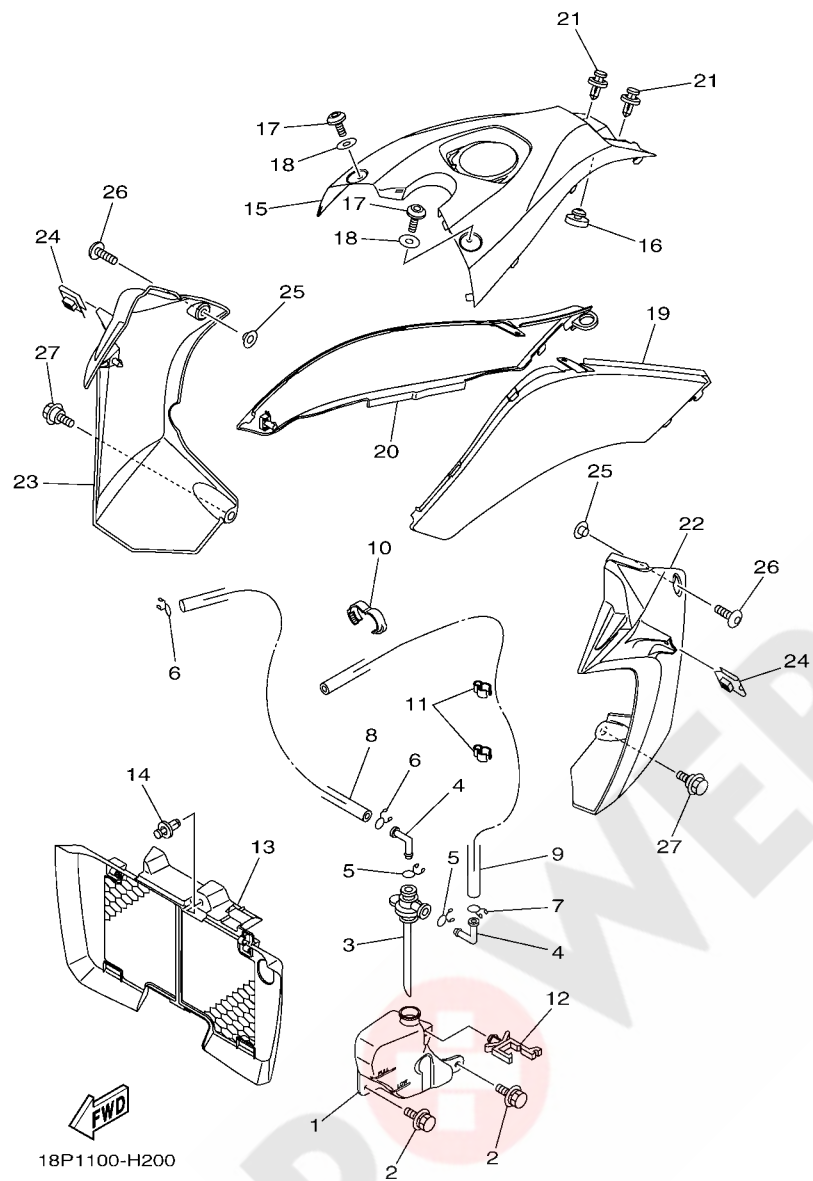


FIG. 20 SIDE COVER

REF. NO.	PART NO.	DESCRIPTION	CAN	EUR	OCE	JPN	REMARKS
1	18P-21871-00	TANK, RECOVERY	1	1	1	1	
2	90119-06152	BOLT, WITH WASHER	2	2	2	2	
3	18P-21875-00	CAP	1	1	1	1	
4	26H-21828-00	ELBOW	2	2	2	2	
5	90467-11019	CLIP	2	2	2	2	
6	90467-08003	CLIP	2	2	2	2	
7	90467-08003	CLIP	1	1	1	1	
8	90445-09251	HOSE (L350)	1	1	1	1	
9	90445-09123	HOSE (L730)	1	1	1	1	
10	90464-16001	CLAMP	1	1	1	1	
11	90464-15065	CLAMP	2	2	2	2	
12	90464-15M08	CLAMP	1	1	1	1	
13	18P-12467-00	COVER, RADIATOR	1	1	1	1	
14	90269-07076	RIVET	1	1	1	1	
15	18P-2171A-00	COVER, TOP	1	1	1	1	UR FOR DPBSE
	18P-2171A-10	COVER, TOP	1	1	1		UR FOR BWS1
16	22W-24741-00	PAD, SEAT	1	1	1	1	
17	90111-06038	BOLT, HEX. SOCKET BUTTON	2	2	2	2	
18	90201-06085	WASHER, PLATE	2	2	2	2	
19	18P-21711-00	COVER, SIDE 1	1	1	1	1	
20	18P-21721-00	COVER, SIDE 2	1	1	1	1	
21	90269-07010	RIVET	2	2	2	2	
22	18P-21731-20	COVER, SIDE 3	1	1	1	1	UR FOR DPBSE
	18P-21731-10	COVER, SIDE 3	1	1	1		UR FOR BWS1
23	18P-21741-20	COVER, SIDE 4	1	1	1	1	UR FOR DPBSE
	18P-21741-10	COVER, SIDE 4	1	1	1		UR FOR BWS1
24	90183-061A5	NUT, SPRING	2	2	2	2	

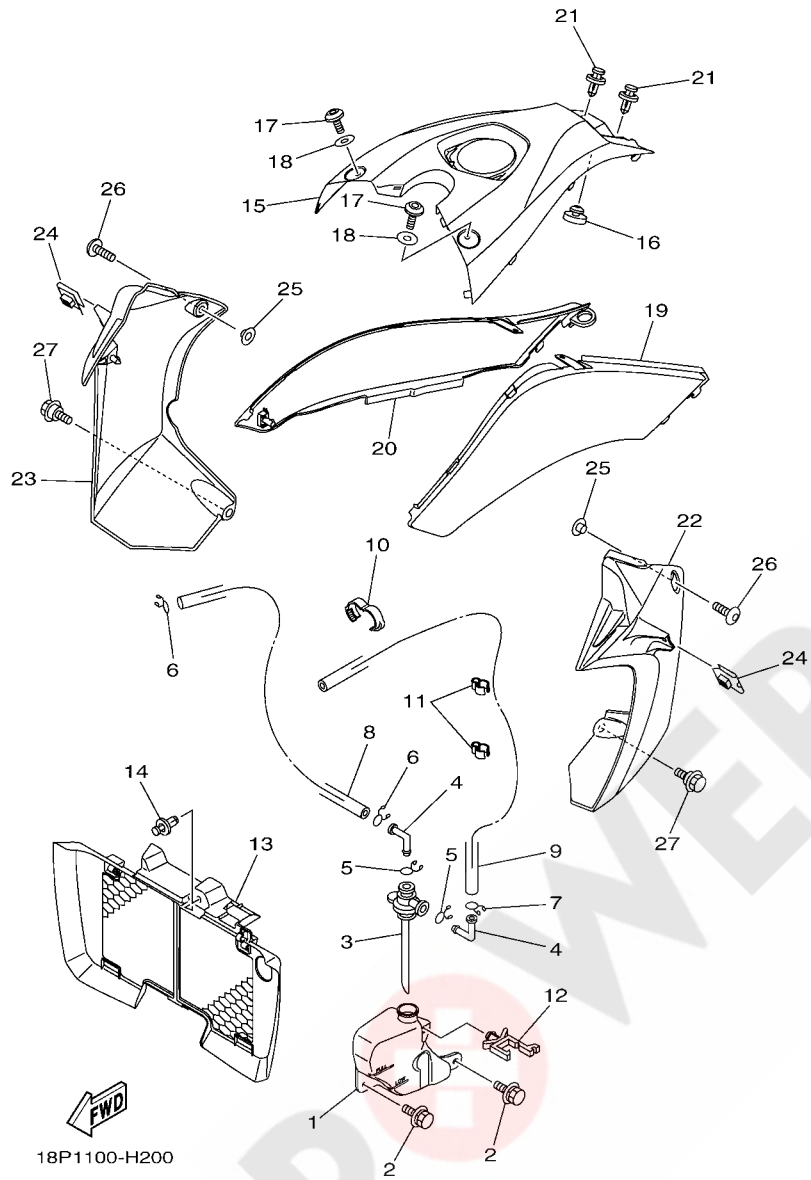
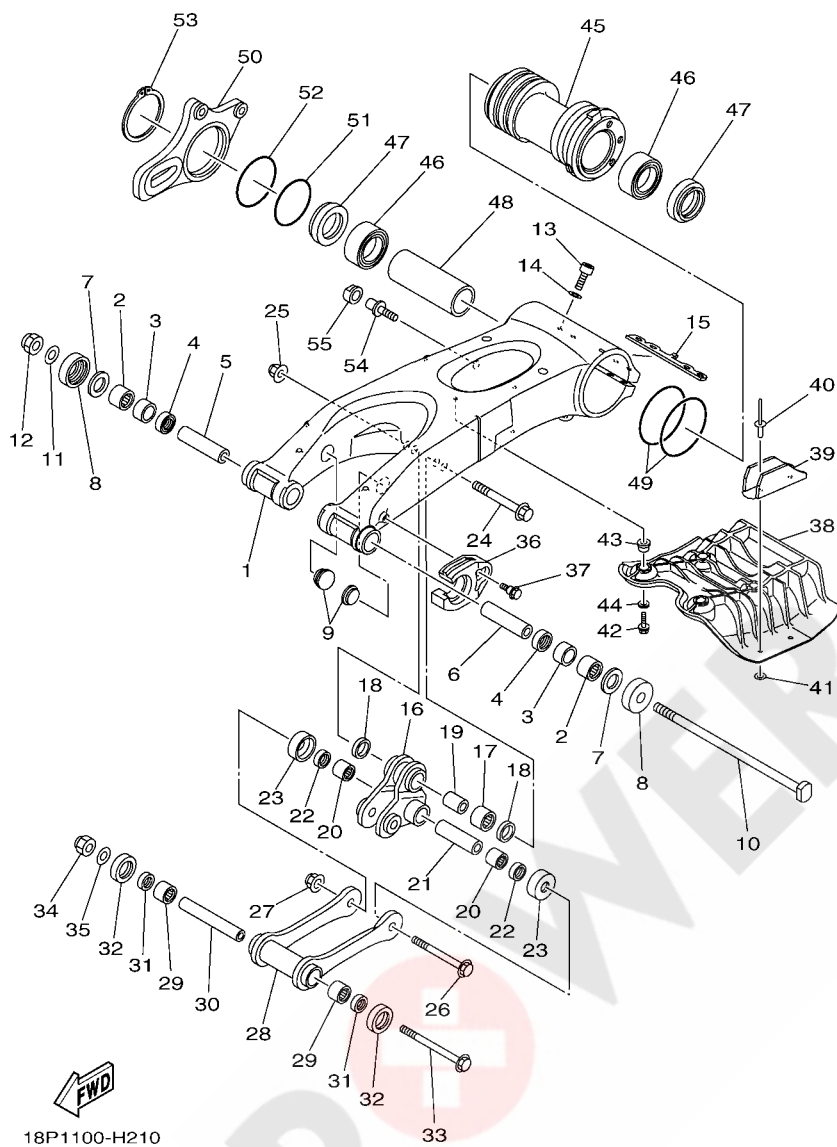


FIG. 20 SIDE COVER

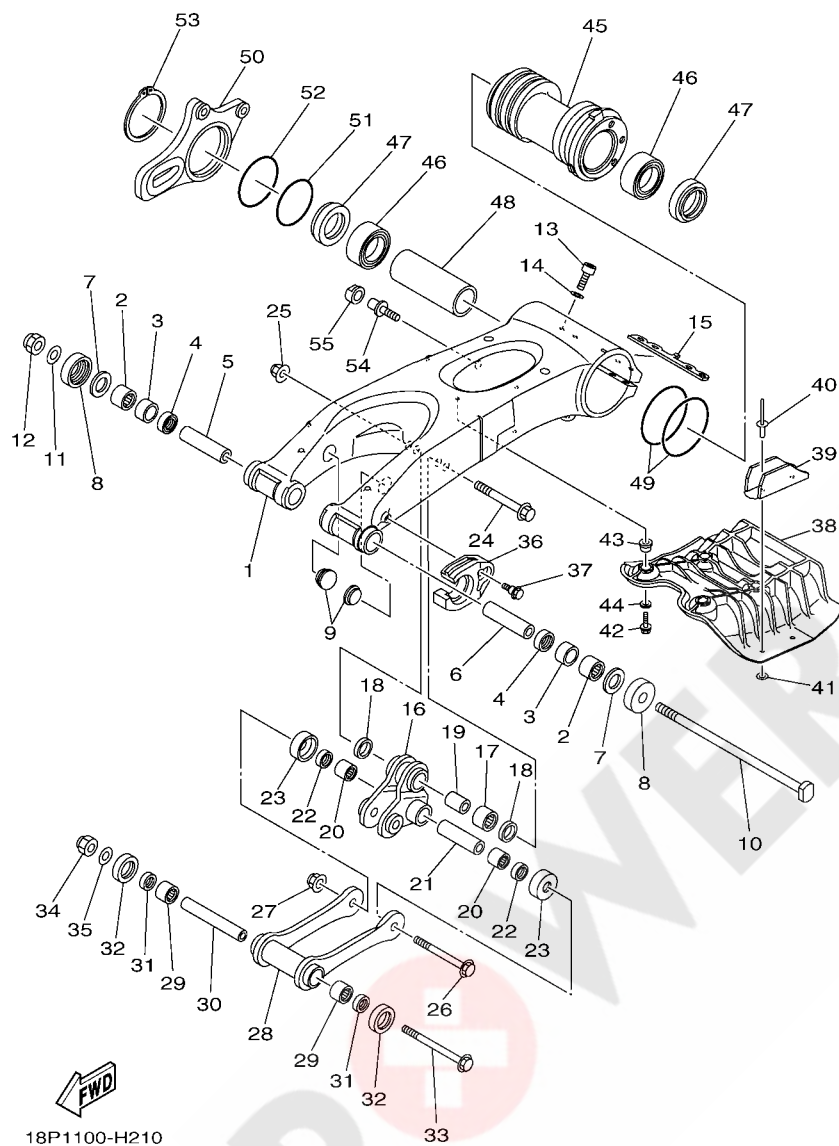
REF. NO.	PART NO.	DESCRIPTION	CAN	EUR	OCE	JPN	REMARKS
25	90387-06170	COLLAR	2	2	2	2	
26	90111-06084	BOLT,HEX. SOCKET BUTTON	2	2	2	2	
27	90109-06172	BOLT	2	2	2	2	
-----							
-----							
-----							
-----							
-----							
-----							
-----							
-----							
-----							
-----							



18P1100-H210

FIG. 21 REAR ARM

REF. NO.	PART NO.	DESCRIPTION	CAN	EUR	OC	JPN	REMARKS
1	18P-22110-00	REAR ARM COMP.	1	1	1	1	
2	93317-22237	BEARING	2	2	2	2	
3	90380-22111	BUSH, SOLID	2	2	2	2	
4	93106-22019	OIL SEAL (DC 22-28-8)	2	2	2	2	
5	90387-16027	COLLAR	1	1	1	1	
6	90387-160W1	COLLAR	1	1	1	1	
7	3YF-22149-00	WASHER	2	2	2	2	
8	4X7-22129-00	COVER, THRUST 2	2	2	2	2	
9	90338-23004	PLUG	2	2	2	2	
10	18P-22141-00	SHAFT, PIVOT	1	1	1	1	
11	90201-16018	WASHER, PLATE	1	1	1	1	
12	90185-16002	NUT, SELF-LOCKING	1	1	1	1	
13	91314-08040	BOLT, HEXAGON SOCKET HEAD	4	4	4	4	
14	92903-08600	WASHER, PLATE	4	4	4	4	
15	5TG-22475-00	SEAL, DUST	1	1	1	1	
16	18P-2217A-00	ARM, RELAY 1	1	1	1	1	
17	93315-32056	BEARING	1	1	1	1	
18	93109-20001	OIL SEAL	2	2	2	2	
19	90387-12043	COLLAR	1	1	1	1	
20	93315-31758	BEARING	2	2	2	2	
21	90387-12041	COLLAR	1	1	1	1	
22	93109-17071	OIL SEAL	2	2	2	2	
23	55K-22129-00	COVER, THRUST 2	2	2	2	2	
24	90105-12064	BOLT, FLANGE	1	1	1	1	
25	90185-12002	NUT, SELF-LOCKING	1	1	1	1	
26	90105-12065	BOLT, FLANGE	1	1	1	1	
27	90185-12002	NUT, SELF-LOCKING	1	1	1	1	

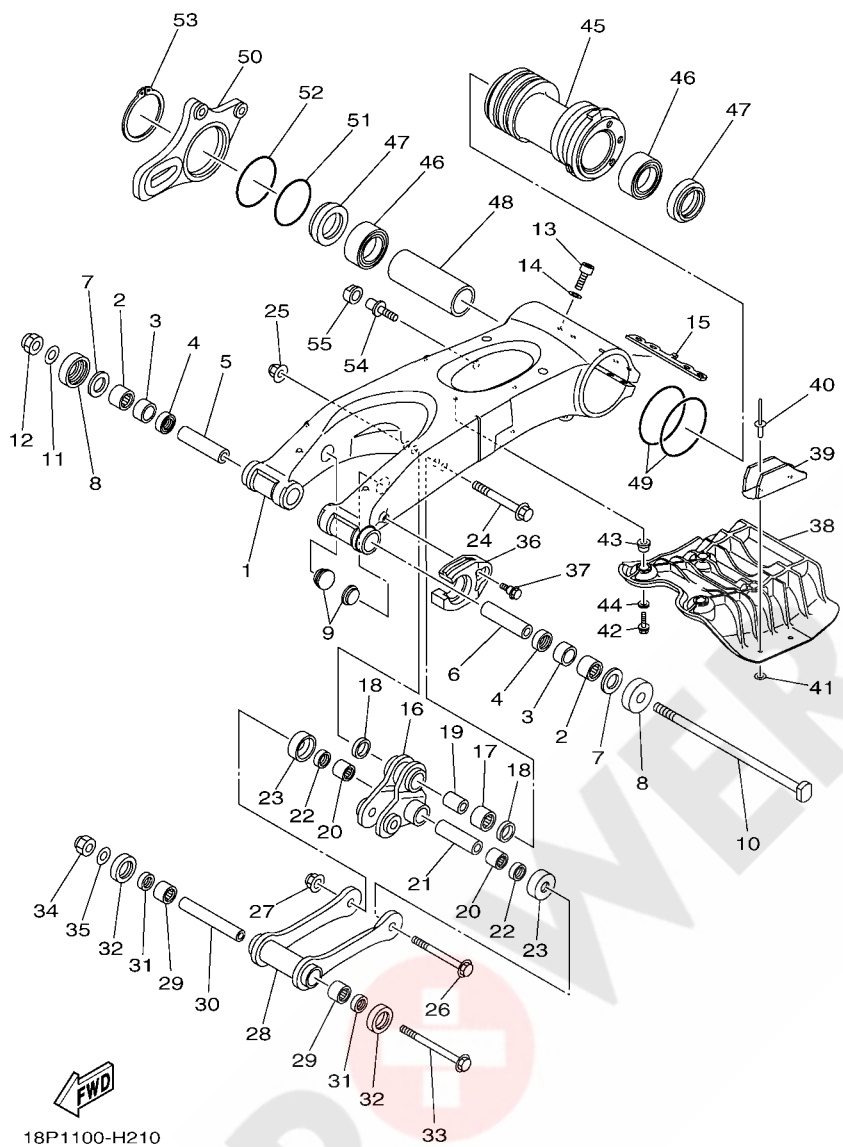


18P1100-H210

FIG. 21 REAR ARM

REF. NO.	PART NO.	DESCRIPTION	CAN	EUR	OCE	JPN	REMARKS
28	18P-2217F-00	ROD, CONNECTING 1	1	1	1	1	
29	93315-31758	BEARING	2	2	2	2	
30	90387-12042	COLLAR	1	1	1	1	
31	93109-17071	OIL SEAL	2	2	2	2	
32	55K-22129-00	COVER, THRUST 2	2	2	2	2	
33	90105-12066	BOLT, FLANGE	1	1	1	1	
34	90185-12007	NUT, SELF-LOCKING	1	1	1	1	
35	90201-12032	WASHER, PLATE	1	1	1	1	
36	18P-22151-10	SEAL, GUARD	1	1	1	1	
37	90109-06172	BOLT	1	1	1	1	
38	18P-22361-00	GUARD 1	1	1	1	1	
39	5TG-22153-10	GUARD, CHAIN	1	1	1	1	
40	90267-47187	RIVET, BLIND (4.7X16.4 BLACK)	2	2	2	2	
41	90201-04027	WASHER, PLATE	2	2	2	2	
42	95812-06025	BOLT, FLANGE	4	4	4	4	
43	90387-06151	COLLAR	4	4	4	4	
44	90201-06033	WASHER, PLATE	4	4	4	4	
45	5TG-25311-20	HUB, REAR	1	1	1	1	
46	93304-20812	BEARING	2	2	2	2	
47	93106-48001	OIL SEAL	2	2	2	2	
48	5TG-25317-00	SPACER, BEARING	1	1	1	1	
49	1S3-23147-01	O-RING	2	2	2	2	
50	5TG-25721-20	BRACKET, CALIPER	1	1	1	1	
51	93210-71001	O-RING	1	1	1	1	
52	93210-66001	O-RING	1	1	1	1	
53	93410-67085	CIRCLIP	1	1	1	1	
54	90110-12001	BOLT, HEXAGON SOCKET HEAD	1	1	1	1	

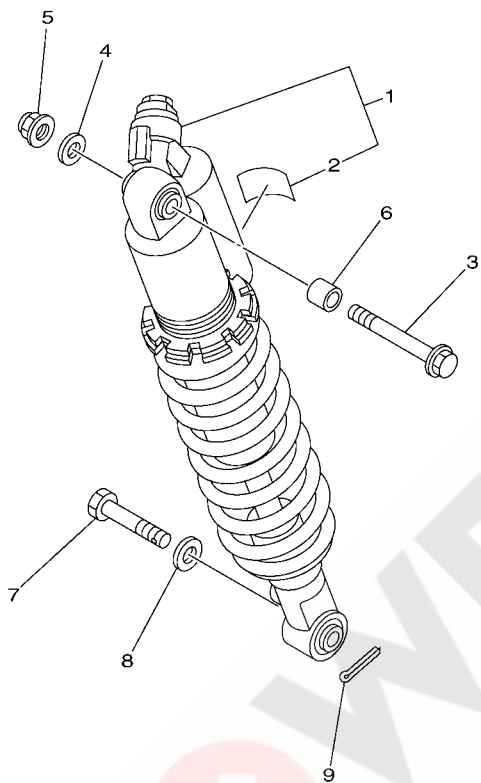
FIG. 21 REAR ARM



REF. NO.	PART NO.	DESCRIPTION	CAN	EUR	OCE	JPN	REMARKS
55	90387-16014	COLLAR	1	1	1	1	

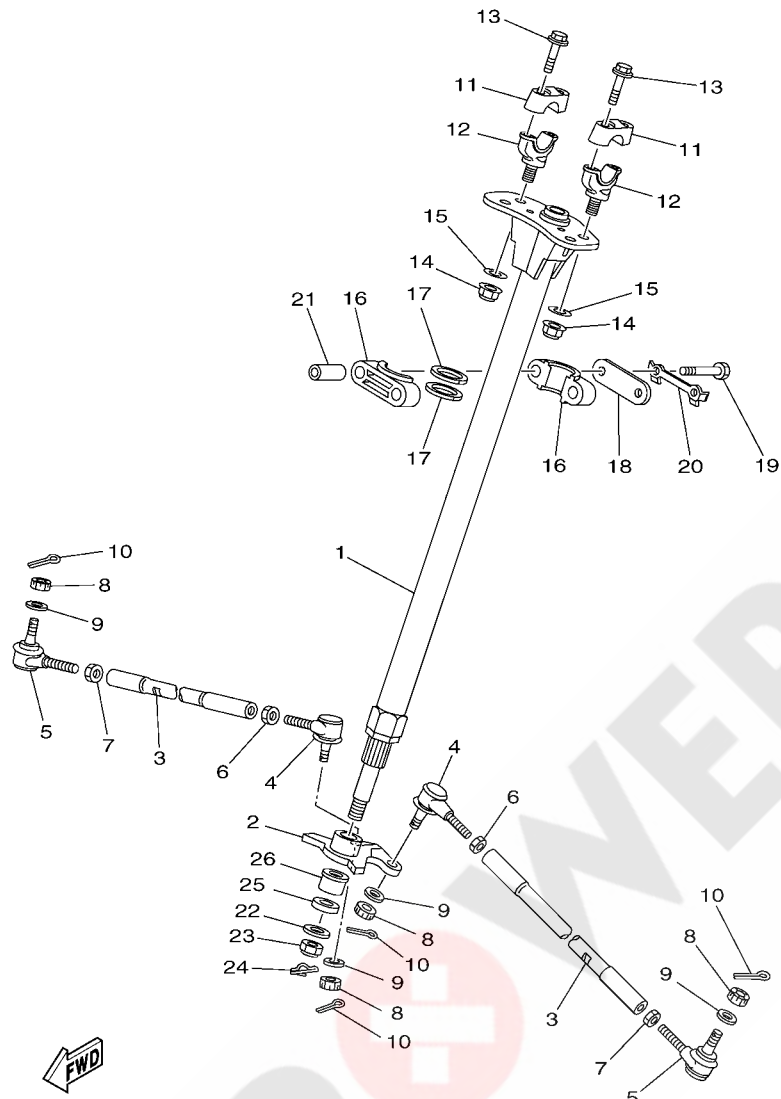


**FIG. 22 REAR SUSPENSION**



REF. NO.	PART NO.	DESCRIPTION	CAN	EUR	OCE	JPN	REMARKS
1	18P-22210-10	SHOCK ABSORBER ASSY, REAR	1				UR FOR DPBSE
	18P-22210-50	SHOCK ABSORBER ASSY, REAR	1				UR FOR BWS1
	18P-22210-20	SHOCK ABSORBER ASSY, REAR		1	1		UR FOR DPBSE
	18P-22210-60	SHOCK ABSORBER ASSY, REAR		1	1		UR FOR BWS1
	18P-22210-A0	SHOCK ABSORBER ASSY, REAR				1	FOR DPBSE
2	4AA-22259-70	.LABEL, WARNING	1				
	4AA-22259-40	.LABEL, WARNING		1	1		
	4AA-22259-50	.LABEL, WARNING				1	
3	90105-12038	BOLT, FLANGE	1	1	1	1	
4	90201-12032	WASHER, PLATE	1	1	1	1	
5	90185-12002	NUT, SELF-LOCKING	1	1	1	1	
6	90387-12046	COLLAR	1	1	1	1	
7	90102-12005	BOLT, PIN HOLE HEX.	1	1	1	1	
8	90201-12034	WASHER, PLATE	1	1	1	1	
9	91402-30025	PIN, COTTER	1	1	1	1	

  
18P1100-H220

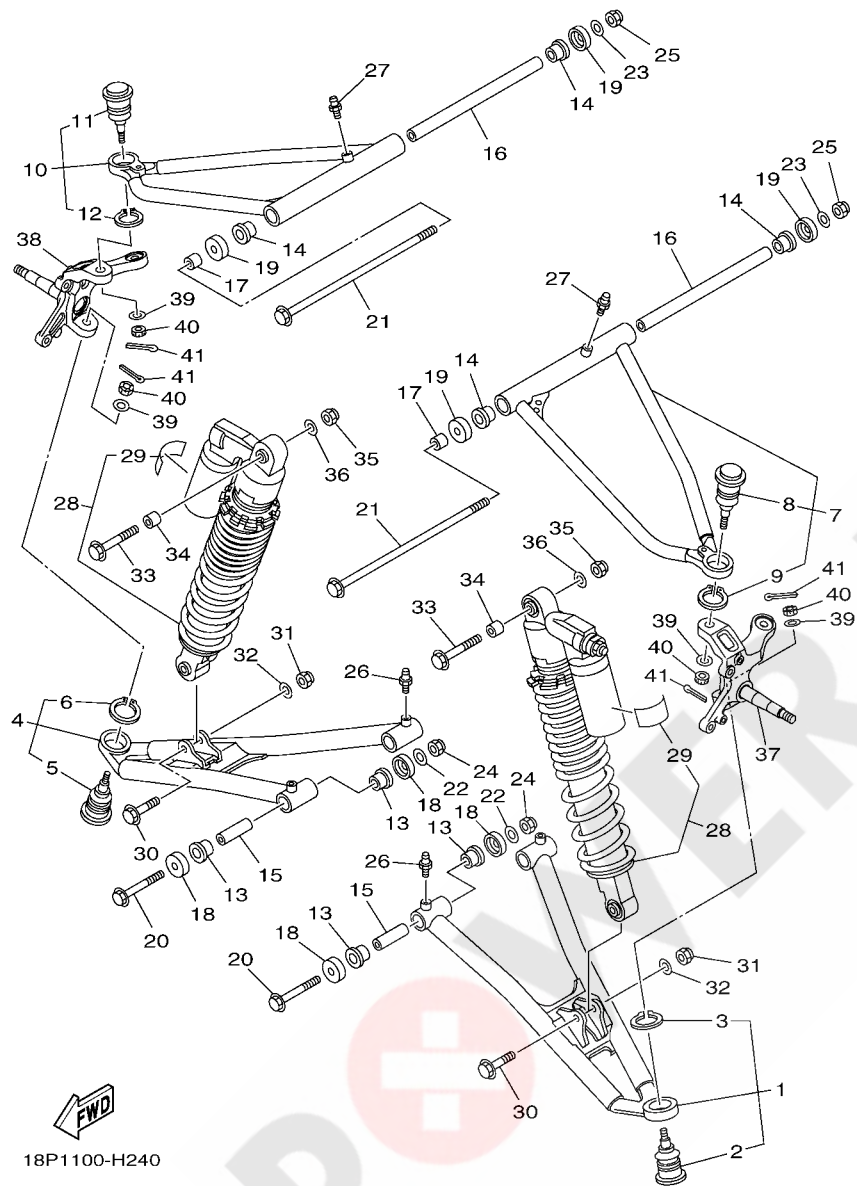


18P1100-H230

FIG. 23 STEERING

REF. NO.	PART NO.	DESCRIPTION	CAN	EUR	OCE	JPN	REMARKS
1	18P-23813-00	COLUMN, STEERING 2	1	1	1	1	
2	18P-23816-00	ARM, PITMAN	1	1	1	1	
3	18P-23831-00	ROD, TIE	2	2	2	2	
4	1S3-23841-20	JOINT, UNIVERSAL 1	2	2	2	2	
5	1S3-23845-20	JOINT, UNIVERSAL 2	2	2	2	2	
6	90170-12055	NUT	2	2	2	2	
7	90170-12054	NUT	2	2	2	2	(RH. THREAD)
8	90171-10001	NUT, CASTLE	4	4	4	4	
9	90209-10229	WASHER	4	4	4	4	
10	91402-20020	PIN, COTTER	4	4	4	4	
11	18P-23441-00	HOLDER, HANDLE UPPER	2	2	2	2	
12	18P-23442-10	HOLDER, HANDLE UNDER	2	2	2	2	
13	90105-08154	BOLT, FLANGE	4	4	4	4	
14	90185-12002	NUT, SELF-LOCKING	2	2	2	2	
15	90201-12034	WASHER, PLATE	2	2	2	2	
16	1UY-23812-00	PLANE BEARING, STEERING	2	2	2	2	
17	93112-31011	OIL SEAL	2	2	2	2	
18	1UY-23868-01	BRACKET, STEERING LOWER	1	1	1	1	
19	97022-08065	BOLT	2	2	2	2	
20	1UY-23894-01	WASHER, LOCK 1	1	1	1	1	
21	90387-090R0	COLLAR	2	2	2	2	
22	90201-14021	WASHER, PLATE	1	1	1	1	
23	90185-14009	NUT, SELF-LOCKING	1	1	1	1	
24	91402-20025	PIN, COTTER	1	1	1	1	
25	90387-176R6	COLLAR	1	1	1	1	
26	90387-17013	COLLAR	1	1	1	1	

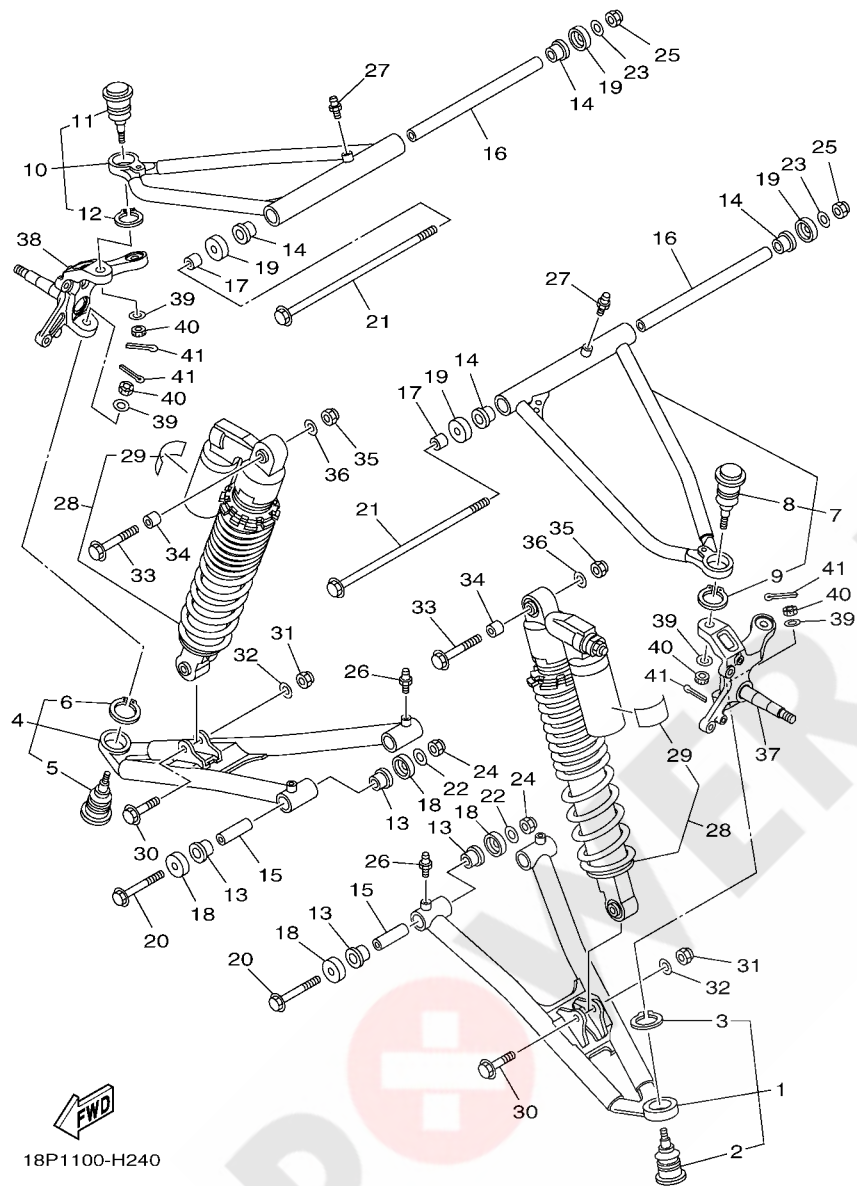
FIG. 24 FRONT SUSPENSION & WHEEL



18P1100-H240

REF. NO.	PART NO.	DESCRIPTION	CAN	EUR	OCE	JPN	REMARKS
1	18P-23570-00-33	FRONT LOWER ARM COMP. (LEFT)	1	1	1	1	YB
2	5LP-23579-00	.BALL JOINT 2	1	1	1	1	
3	99009-30400	.CIRCLIP	1	1	1	1	
4	18P-23580-00-33	FRONT LOWER ARM COMP. (RIGHT)	1	1	1	1	YB
5	5LP-23579-00	.BALL JOINT 2	1	1	1	1	
6	99009-30400	.CIRCLIP	1	1	1	1	
7	18P-23540-00-33	FRONT UPPER ARM COMP. (LEFT)	1	1	1	1	YB
8	5LP-23579-00	.BALL JOINT 2	1	1	1	1	
9	99009-30400	.CIRCLIP	1	1	1	1	
10	18P-23550-00-33	FRONT UPPER ARM COMP. (RIGHT)	1	1	1	1	YB
11	5LP-23579-00	.BALL JOINT 2	1	1	1	1	
12	99009-30400	.CIRCLIP	1	1	1	1	
13	90381-15088	BUSH, SOLID	8	8	8	8	
14	90381-15088	BUSH, SOLID	4	4	4	4	
15	90387-101R3	COLLAR	4	4	4	4	
16	90387-10069	COLLAR	2	2	2	2	
17	90387-10043	COLLAR	2	2	2	2	
18	5YT-23517-00	COVER, THRUST 1	8	8	8	8	
19	5YT-23517-00	COVER, THRUST 1	4	4	4	4	
20	90105-10135	BOLT, FLANGE	4	4	4	4	
21	90105-10301	BOLT, FLANGE	2	2	2	2	
22	90201-10037	WASHER, PLATE	4	4	4	4	
23	90201-10037	WASHER, PLATE	2	2	2	2	
24	90185-10012	NUT, SELF-LOCKING	4	4	4	4	
25	90185-10012	NUT, SELF-LOCKING	2	2	2	2	
26	93700-06004	NIPPLE, GREASE	4	4	4	4	
27	93700-06004	NIPPLE, GREASE	2	2	2	2	

FIG. 24 FRONT SUSPENSION & WHEEL



18P1100-H240

REF. NO.	PART NO.	DESCRIPTION	CAN	EUR	OCÉ	JPN	REMARKS
28	18P-23350-10	CUSHION ASSY	2				UR FOR DPBSE
	18P-23350-80	SHOCK ABSORBER ASSY	2				UR FOR BWS1
	18P-23350-20	CUSHION ASSY		2	2		UR FOR DPBSE
	18P-23350-90	SHOCK ABSORBER ASSY		2	2		UR FOR BWS1
	18P-23350-A0	SHOCK ABSORBER ASSY				2	FOR DPBSE
29	4AA-22259-70	.LABEL, WARNING	1				
	4AA-22259-40	.LABEL, WARNING		1	1		
	4AA-22259-50	.LABEL, WARNING				1	
30	90105-10339	BOLT, FLANGE	2	2	2	2	
31	90185-10012	NUT, SELF-LOCKING	2	2	2	2	
32	90201-10035	WASHER, PLATE	2	2	2	2	
33	90105-10351	BOLT, FLANGE	2	2	2	2	
34	90387-10043	COLLAR	2	2	2	2	
35	90185-10012	NUT, SELF-LOCKING	2	2	2	2	
36	90201-10037	WASHER, PLATE	2	2	2	2	
37	18P-23501-00	STEERING KNUCKLE ASSY (LEFT)	1	1	1	1	
38	18P-23502-00	STEERING KNUCKLE ASSY (RIGHT)	1	1	1	1	
39	90209-10229	WASHER	4	4	4	4	
40	90171-10001	NUT, CASTLE	4	4	4	4	
41	91402-20020	PIN, COTTER	4	4	4	4	

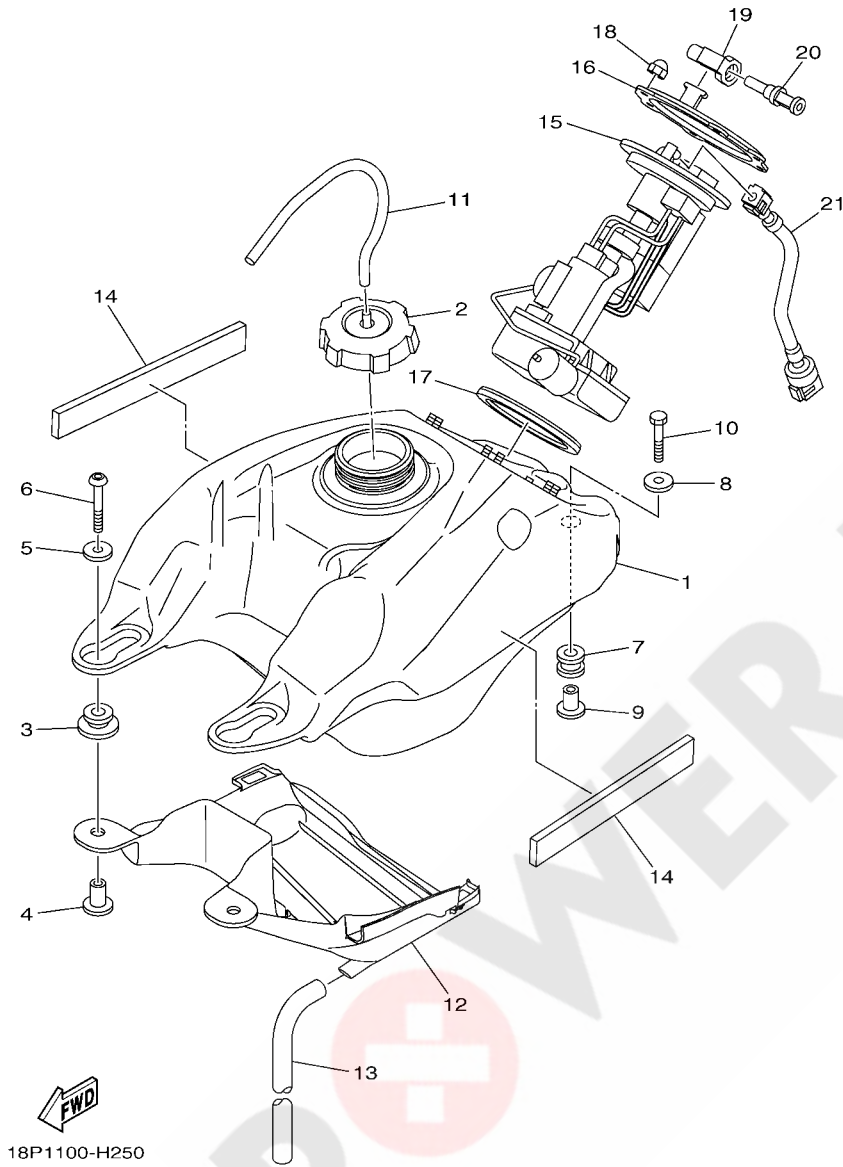
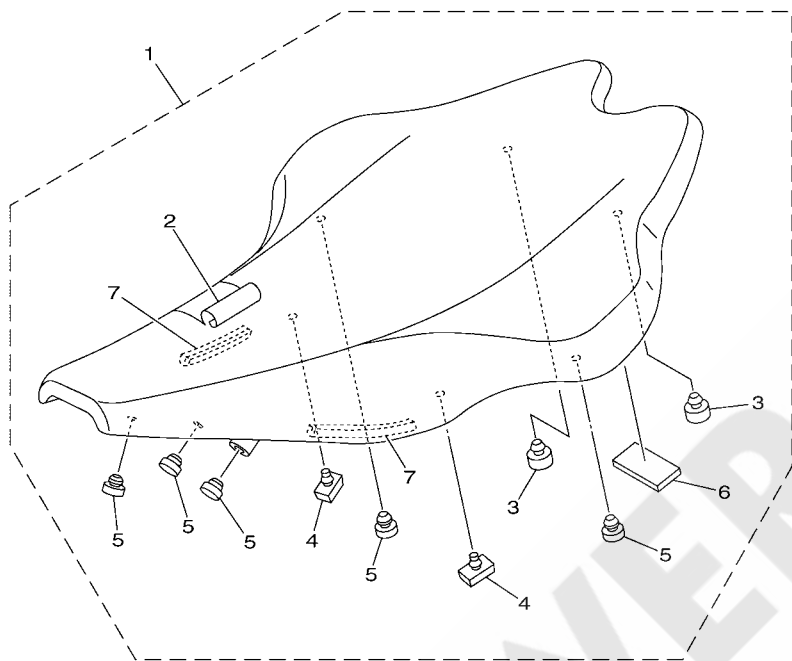


FIG. 25 FUEL TANK

REF. NO.	PART NO.	DESCRIPTION	CAN	EUR	OCE	JPN	REMARKS
1	18P-24110-00	FUEL TANK COMP.	1				
	18P-24110-10	FUEL TANK COMP.		1	1	1	
2	5KM-24610-00	CAP ASSY	1	1	1	1	
3	90480-18004	GROMMET	2	2	2	2	
4	90387-06258	COLLAR	2	2	2	2	
5	90201-06033	WASHER, PLATE	2	2	2	2	
6	92012-06040	BOLT, BUTTON HEAD	2	2	2	2	
7	90480-18290	GROMMET	1	1	1	1	
8	90201-06033	WASHER, PLATE	1	1	1	1	
9	90387-06257	COLLAR	1	1	1	1	
10	95812-06030	BOLT, FLANGE	1	1	1	1	
11	90445-08008	HOSE	1	1	1	1	
12	18P-2414H-00	DAMPER, PLATE 1	1	1	1	1	
13	18P-2247A-00	HOSE 1	1	1	1	1	
14	90520-08001	DAMPER, PLATE	2	2	2	2	
15	18P-13907-00	FUEL PUMP COMP.	1	1	1	1	
16	18P-24491-00	BRACKET, FUEL PUMP	1	1	1	1	
17	1S3-24486-00	O-RING	1	1	1	1	
18	95302-06800	NUT, CROWN	6	6	6	6	
19	18P-2464V-00	CASE, CAP	1	1	1	1	
20	18P-2467E-00	CAP	1	1	1	1	
21	18P-13971-00	PIPE, FUEL 1	1	1	1	1	

FIG. 26 SEAT



REF. NO.	PART NO.	DESCRIPTION	CAN	EUR	OCE	JPN	REMARKS
1	18P-24710-00	SINGLE SEAT ASSY	1	1	1	1	UR FOR DPBSE
	18P-24710-20	SINGLE SEAT ASSY	1	1	1		UR FOR BWS1
2	18P-2470F-00	.SEAT COVER COMP.	1	1	1	1	UR FOR DPBSE
	18P-2470F-20	.SEAT COVER COMP.	1	1	1	1	UR FOR BWS1
3	371-27114-00	.STOPPER, MAIN STAND	2	2	2	2	
4	214-24724-00	.DAMPER, SEAT	2	2	2	2	
5	22W-24741-00	.PAD, SEAT	5	5	5	5	
6	18P-24725-00	.SPACER 1	1	1	1	1	
7	18P-24723-00	.DAMPER, SEAT	2	2	2	2	

 18P1100-H260

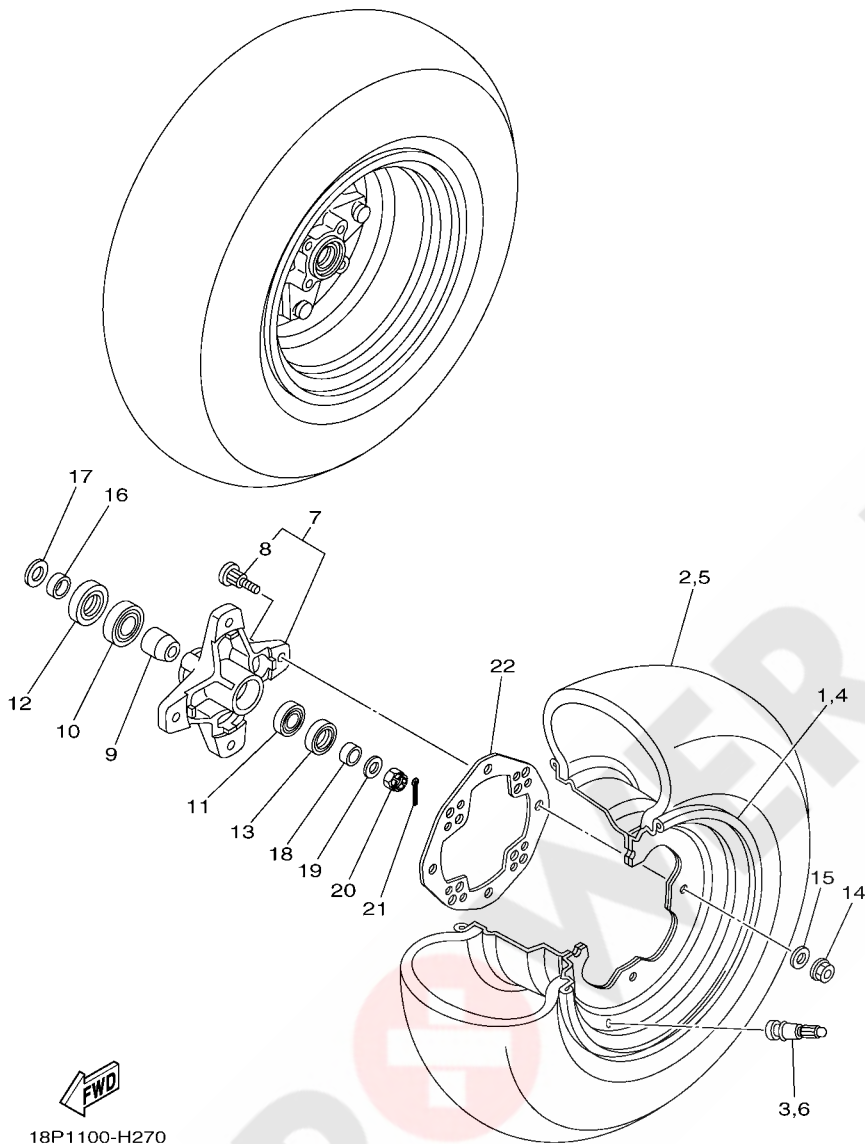


FIG. 27 FRONT WHEEL

REF. NO.	PART NO.	DESCRIPTION	CAN	EUR	OCE	JPN	REMARKS
1	1S3-25180-11	WHEEL COMP.	1	1	1	1	
2	94107-10025	TIRE (AT21X7R10 KT351 T/L(N))	1	1	1	1	DUNLOP
3	93900-00030	VALVE, RIM (TR412)	1	1	1	1	TAIHEIYO
4	1S3-25180-11	WHEEL COMP.	1	1	1	1	
5	94107-10025	TIRE (AT21X7R10 KT351 T/L(N))	1	1	1	1	DUNLOP
6	93900-00030	VALVE, RIM (TR412)	1	1	1	1	TAIHEIYO
7	1S3-25111-00	HUB, FRONT	2	2	2	2	
8	90114-10006	.BOLT, SERRATION	4	4	4	4	
9	5LP-25117-00	SPACER, BEARING	2	2	2	2	
10	93306-00446	BEARING	2	2	2	2	
11	93306-20231	BEARING	2	2	2	2	
12	93105-26026	OIL SEAL	2	2	2	2	
13	93102-22216	OIL SEAL	2	2	2	2	
14	95702-10500	NUT, FLANGE	8	8	8	8	
15	92902-10200	WASHER	8	8	8	8	
16	90387-20005	COLLAR	2	2	2	2	
17	90201-20022	WASHER, PLATE	2	2	2	2	
18	90387-150R1	COLLAR	2	2	2	2	
19	90201-14586	WASHER, PLATE	2	2	2	2	
20	90171-14002	NUT, CASTLE	2	2	2	2	
21	91402-30025	PIN, COTTER	2	2	2	2	
22	1S3-25127-00	COVER, PLATE	2	2	2	2	

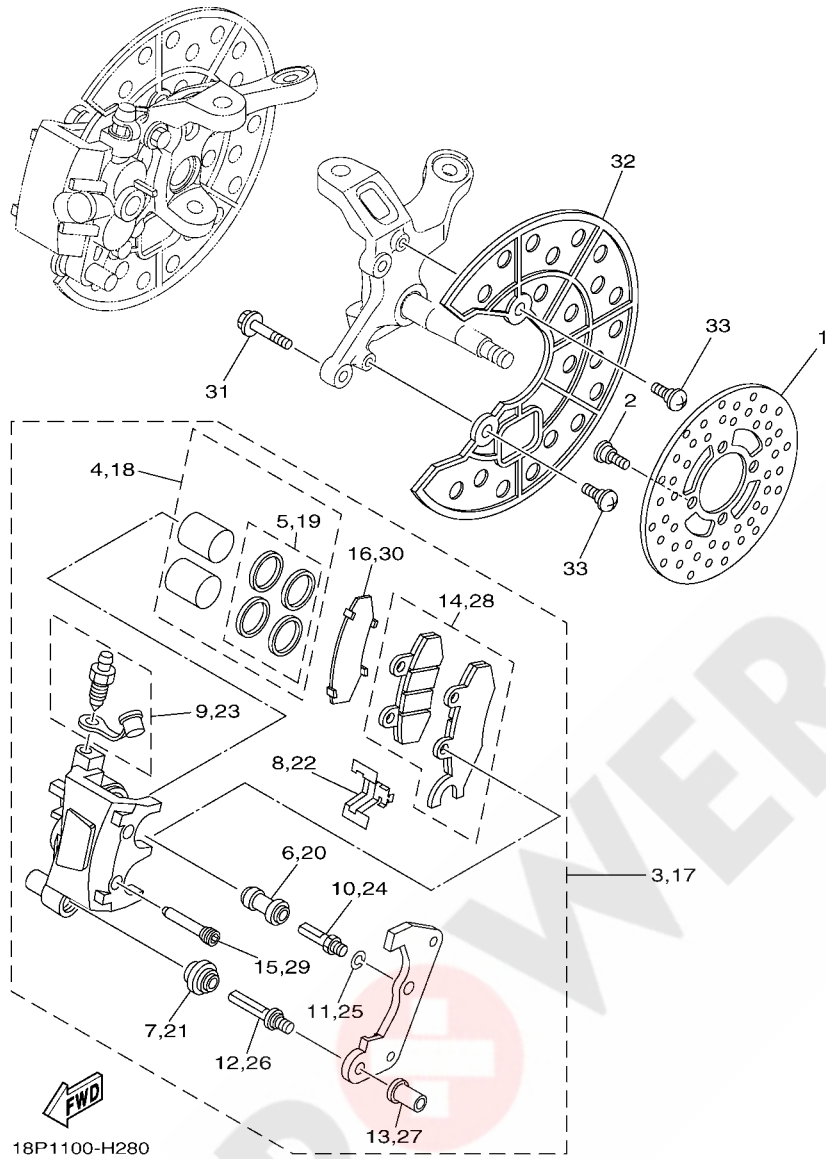


FIG. 28 FRONT BRAKE CALIPER

REF. NO.	PART NO.	DESCRIPTION	CAN	EUR	OC	JPN	REMARKS
1	3GD-2582T-10	DISC, BRAKE (LEFT)	2	2	2	2	
2	90109-08082	BOLT	8	8	8	8	
3	5TG-2580T-11	CALIPER ASSY (LEFT)	1	1	1	1	
4	5TG-W0057-00	.PISTON ASSY, CALIPER	1	1	1	1	
5	3LC-W0047-50	..CALIPER SEAL KIT	1	1	1	1	
6	1UY-25937-51	.BOOT 2	1	1	1	1	
7	3JD-25917-00	.BOOT, CALIPER	1	1	1	1	
8	3JD-25919-00	.SUPPORT, PAD	1	1	1	1	
9	1UY-W0048-50	.BLEED SCREW KIT	1	1	1	1	
10	1UY-25926-51	.BOLT	1	1	1	1	
11	1UY-25938-51	.WASHER, SPRING	1	1	1	1	
12	3JD-25926-00	.BOLT	1	1	1	1	
13	3JD-25961-00	.NUT	1	1	1	1	
14	5TG-W0045-20	.BRAKE PAD KIT	1	1	1	1	
15	5TG-25924-00	.PIN, PAD	2	2	2	2	
16	1S3-25828-00	.SHIM, CALIPER	1	1	1	1	
17	5TG-2580U-11	CALIPER ASSY (RIGHT)	1	1	1	1	
18	5TG-W0057-00	.PISTON ASSY, CALIPER	1	1	1	1	
19	3LC-W0047-50	..CALIPER SEAL KIT	1	1	1	1	
20	1UY-25937-51	.BOOT 2	1	1	1	1	
21	3JD-25917-00	.BOOT, CALIPER	1	1	1	1	
22	3JD-25919-00	.SUPPORT, PAD	1	1	1	1	
23	1UY-W0048-50	.BLEED SCREW KIT	1	1	1	1	
24	1UY-25926-51	.BOLT	1	1	1	1	
25	1UY-25938-51	.WASHER, SPRING	1	1	1	1	
26	3JD-25926-00	.BOLT	1	1	1	1	
27	3JD-25961-00	.NUT	1	1	1	1	



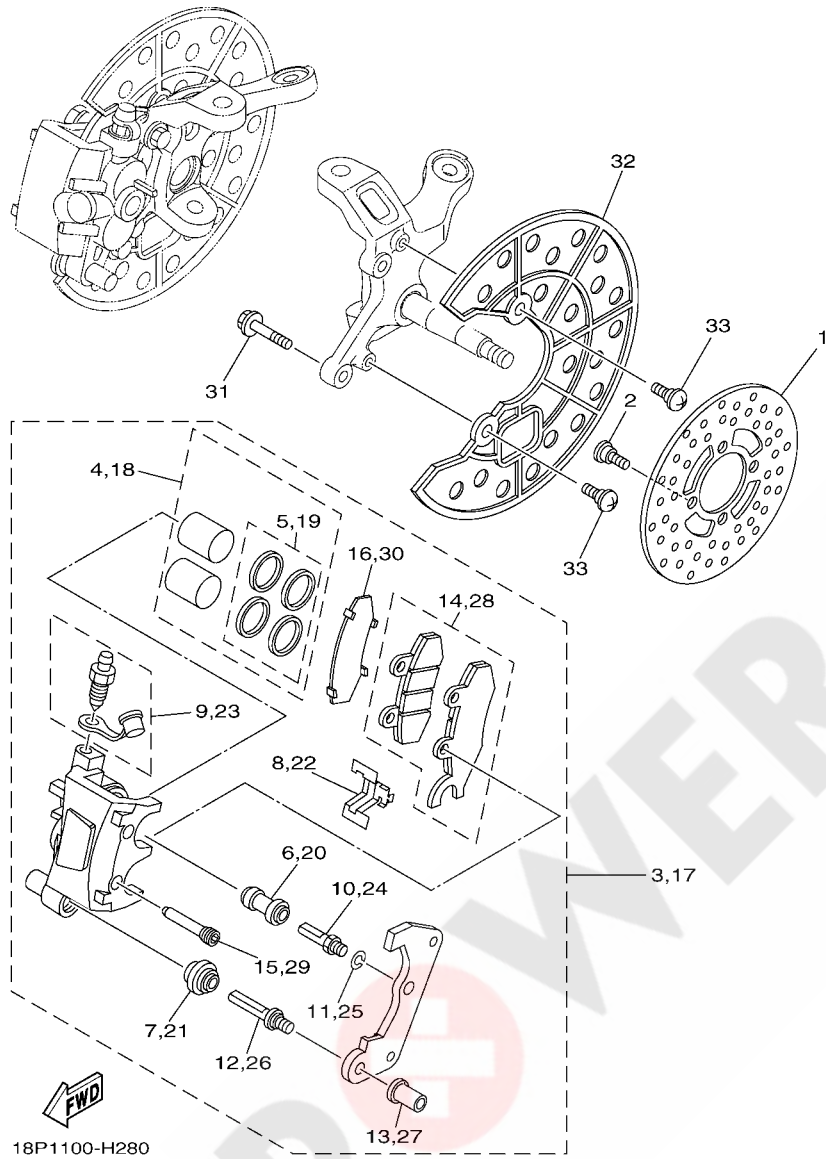
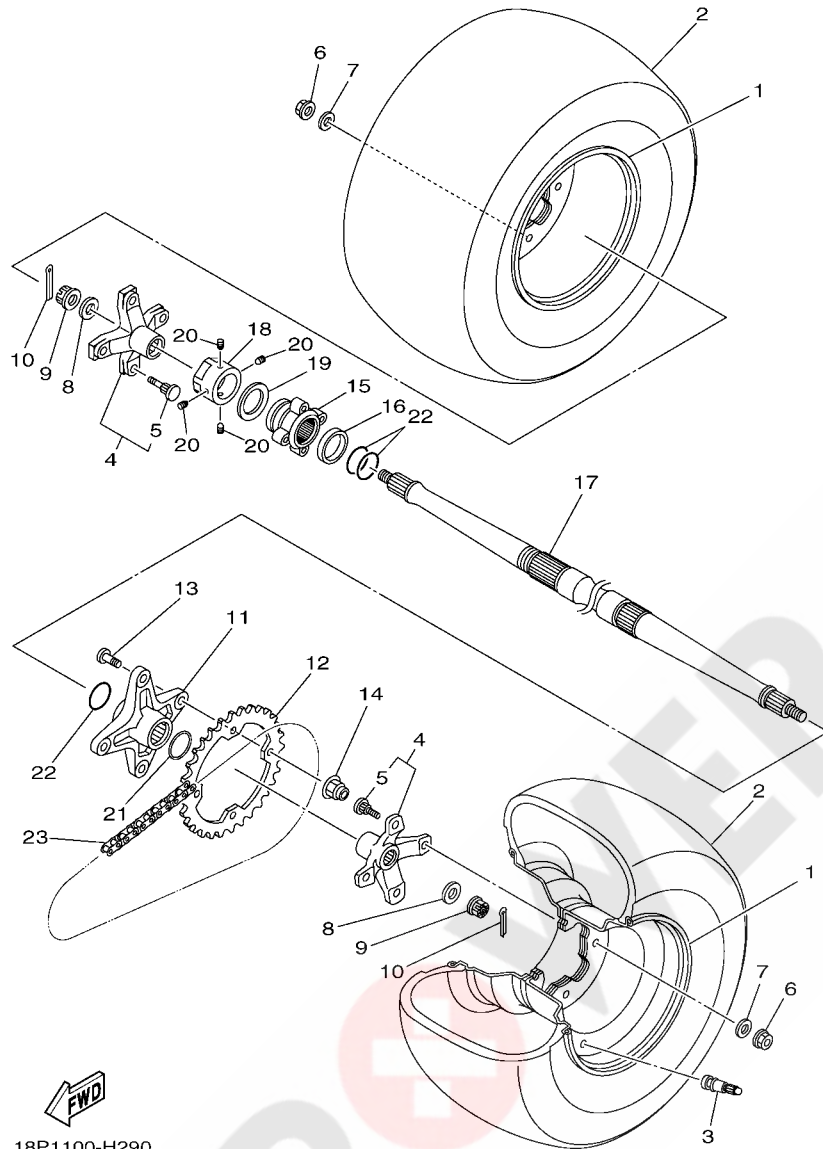


FIG. 28 FRONT BRAKE CALIPER

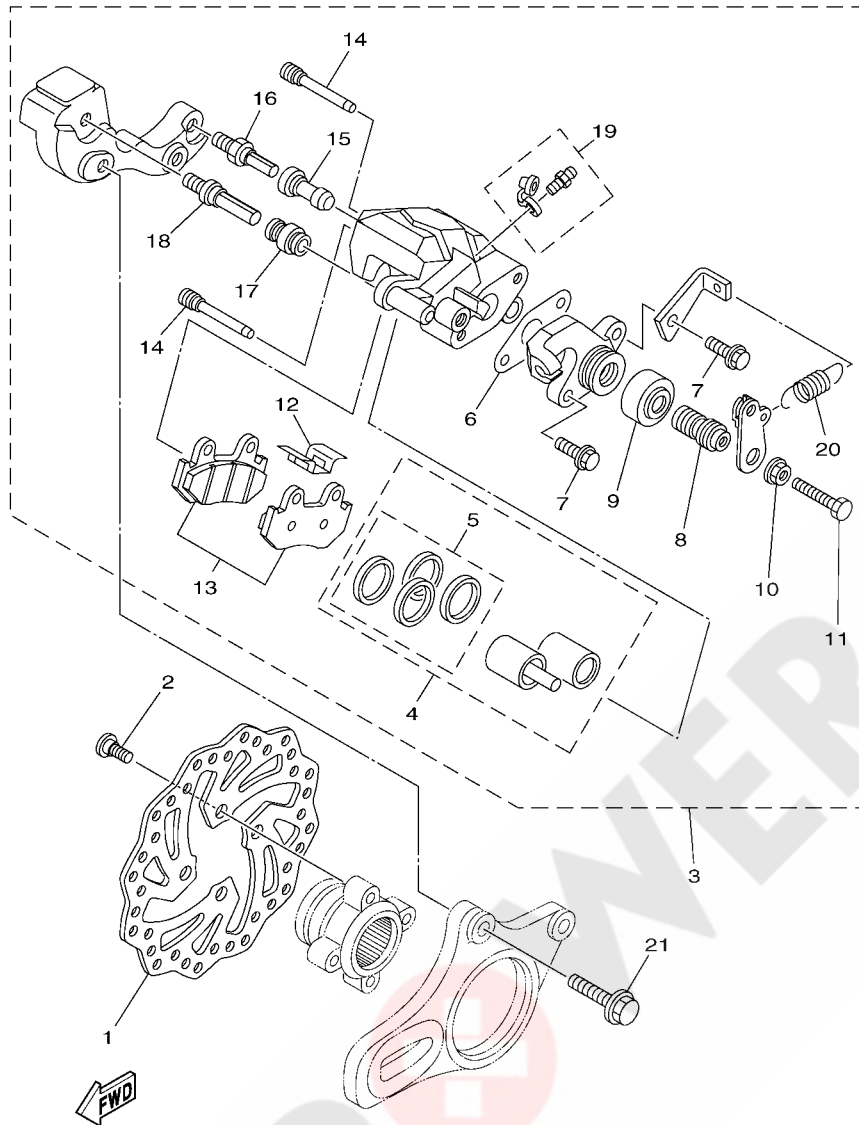
REF. NO.	PART NO.	DESCRIPTION	CAN	EUR	OCE	JPN	REMARKS
28	5TG-W0045-30	.BRAKE PAD KIT	1	1	1	1	
29	5TG-25924-00	.PIN, PAD	2	2	2	2	
30	1S3-25828-00	.SHIM, CALIPER	1	1	1	1	
31	90105-08184	BOLT, FLANGE	4	4	4	4	
32	5TG-2514A-00	RING, WHEEL 1	2	2	2	2	
33	90154-06014	SCREW, BINDING	4	4	4	4	



18P1100-H290

FIG. 29 REAR WHEEL

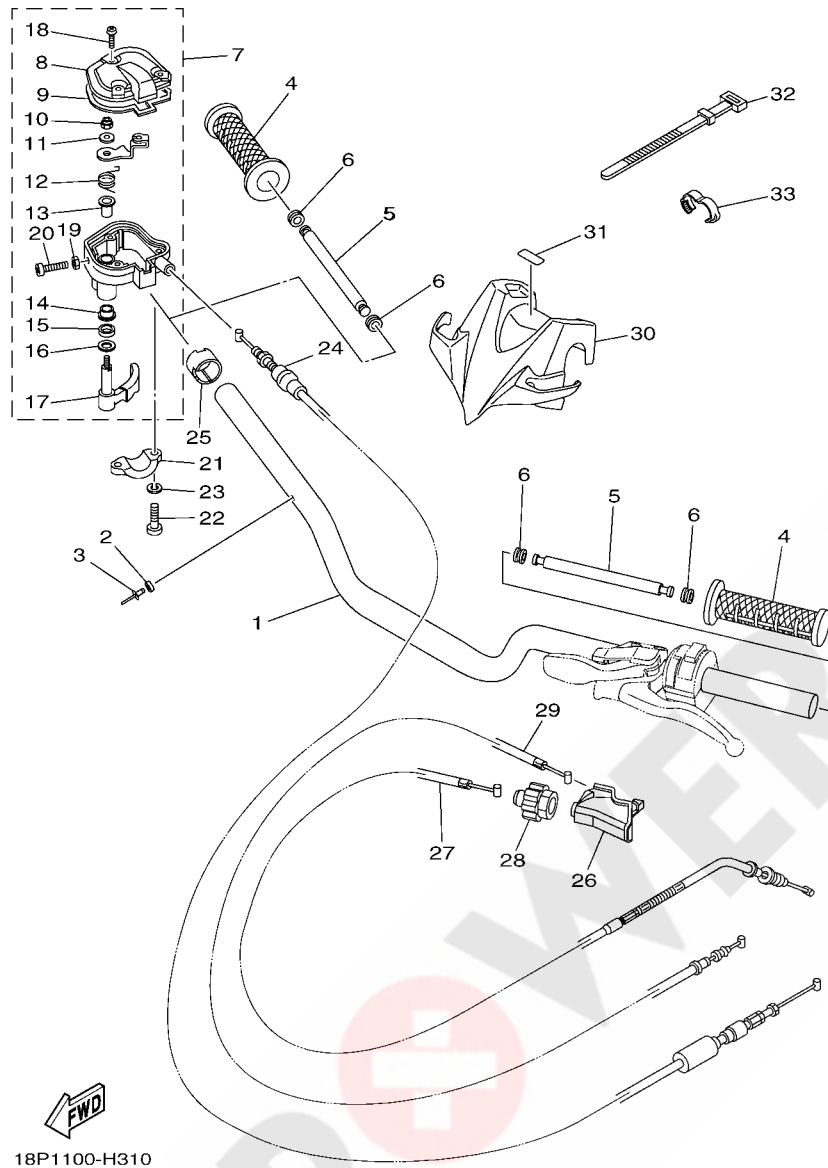
REF. NO.	PART NO.	DESCRIPTION	CAN	EUR	OCE	JPN	REMARKS
1	1S3-25390-11	REAR WHEEL COMP.	2	2	2	2	
2	94110-09025	TIRE (AT20X10R9 KT356 TL(N))	2	2	2	2	DUNLOP
3	93900-00022	VALVE, RIM (TR413)	2	2	2	2	TAIHEIYO
4	18P-25383-00	COLLAR, WHEEL	2	2	2	2	
5	90114-10013	.BOLT, SERRATION	4	4	4	4	
6	95702-10500	NUT, FLANGE	8	8	8	8	
7	92902-10200	WASHER	8	8	8	8	
8	90201-16023	WASHER, PLATE	2	2	2	2	
9	90171-16002	NUT, CASTLE	2	2	2	2	
10	90252-03001	PIN, COTTER	2	2	2	2	
11	18P-25386-00	COLLAR, SPROCKET AXLE	1	1	1	1	
12	5TG-25438-10	SPROCKET, DRIVEN (38T)	1	1	1	1	
13	90109-10013	BOLT	4	4	4	4	
14	90185-10011	NUT, SELF-LOCKING	4	4	4	4	
15	18P-25712-00	BRACKET, DISC	1	1	1	1	
16	90387-40001	COLLAR	1	1	1	1	
17	18P-25381-00	AXLE, WHEEL	1	1	1	1	
18	90179-38001	NUT	1	1	1	1	
19	90208-39001	WASHER, CONICAL SPRING	1	1	1	1	
20	90113-06055	BOLT, SET	4	4	4	4	
21	18P-25415-00	CIRCLIP	1	1	1	1	
22	93210-37003	O-RING	3	3	3	3	
23	94582-13098	CHAIN (DID520MXV 98LE)	1	1	1	1	



18P1100-H300

FIG. 30 REAR BRAKE CALIPER

REF. NO.	PART NO.	DESCRIPTION	CAN	EUR	OCE	JPN	REMARKS
1	1S3-2582W-20	DISK, REAR BRAKE 2	1	1	1	1	
2	90149-08044	SCREW	4	4	4	4	
3	5TG-2580W-20	CALIPER ASSY, REAR 2	1	1	1	1	
4	5TG-W0057-10	.PISTON ASSY, CALIPER	1	1	1	1	
5	5TG-W0047-00	..CALIPER SEAL KIT	1	1	1	1	
6	5TG-25975-00	.RUBBER, BUSHING	1	1	1	1	
7	5UG-25833-00	.BOLT, FITTING	2	2	2	2	
8	5TG-25978-00	.SHAFT L	1	1	1	1	
9	1UY-25974-51	.BOOT	1	1	1	1	
10	1UY-25973-51	.NUT	1	1	1	1	
11	5TG-25972-00	.ADJUST BOLT	1	1	1	1	
12	3LD-25934-01	.SPRING, PAD	1	1	1	1	
13	5TG-W0046-10	.BRAKE PAD KIT 2	1	1	1	1	
14	5DH-25933-00	.PIN, PAD	2	2	2	2	
15	1UY-25937-51	.BOOT 2	1	1	1	1	
16	3SP-25914-51	.PIN, SLIDE	1	1	1	1	
17	3JD-25917-00	.BOOT, CALIPER	1	1	1	1	
18	3SP-25926-51	.BOLT	1	1	1	1	
19	1UY-W0048-50	.BLEED SCREW KIT	1	1	1	1	
20	5TG-25977-50	.SPRING, RETURN	1	1	1	1	
21	90105-101A9	BOLT, FLANGE	2	2	2	2	



18P1100-H310

FIG. 31 STEERING HANDLE & CABLE

REF. NO.	PART NO.	DESCRIPTION	CAN	EUR	OC	JPN	REMARKS
1	5D3-26111-10	HANDLE BAR	1	1	1	1	
2	90387-02001	COLLAR	1	1	1	1	
3	90267-24143	RIVET, BLIND	1	1	1	1	
4	5LP-26241-00	GRIP	2	2	2	2	
5	18P-2622H-00	WEIGHT	2	2	2	2	
6	90480-11006	GROMMET	4	4	4	4	
7	1S3-26250-00	THROTTLE LEVER ASSY	1	1	1	1	
8	1S3-2628F-00	.CAP, GEAR	1	1	1	1	
9	1S3-2628G-00	.GASKET	1	1	1	1	
10	95602-05100	.NUT, U	1	1	1	1	
11	1NV-26398-00	.WASHER	1	1	1	1	
12	1NV-26304-00	.SPRING	1	1	1	1	
13	1NV-26259-01	.COLLAR	1	1	1	1	
14	1NV-2625K-00	.COLLAR	1	1	1	1	
15	93104-09025	.OIL SEAL	1	1	1	1	
16	1NV-26129-00	.WASHER	1	1	1	1	
17	1S3-2625G-00	.LEVER, THROTTLE	1	1	1	1	
18	90149-04278	.SCREW	3	3	3	3	
19	95302-05700	.NUT	1	1	1	1	
20	98502-05020	.SCREW, PAN HEAD	1	1	1	1	
21	1S3-82913-00	HOLDER, LEVER LOWER 1	1	1	1	1	
22	98502-05020	SCREW, PAN HEAD	2	2	2	2	
23	92902-05100	WASHER, SPRING	2	2	2	2	
24	18P-26311-00	CABLE, THROTTLE 1	1	1	1	1	
25	1UY-26259-00	COLLAR	1	1	1	1	
26	5TG-26372-00	COVER, HANDLE LEVER 1	1	1	1	1	
27	18P-26335-00	CABLE, CLUTCH	1	1	1	1	

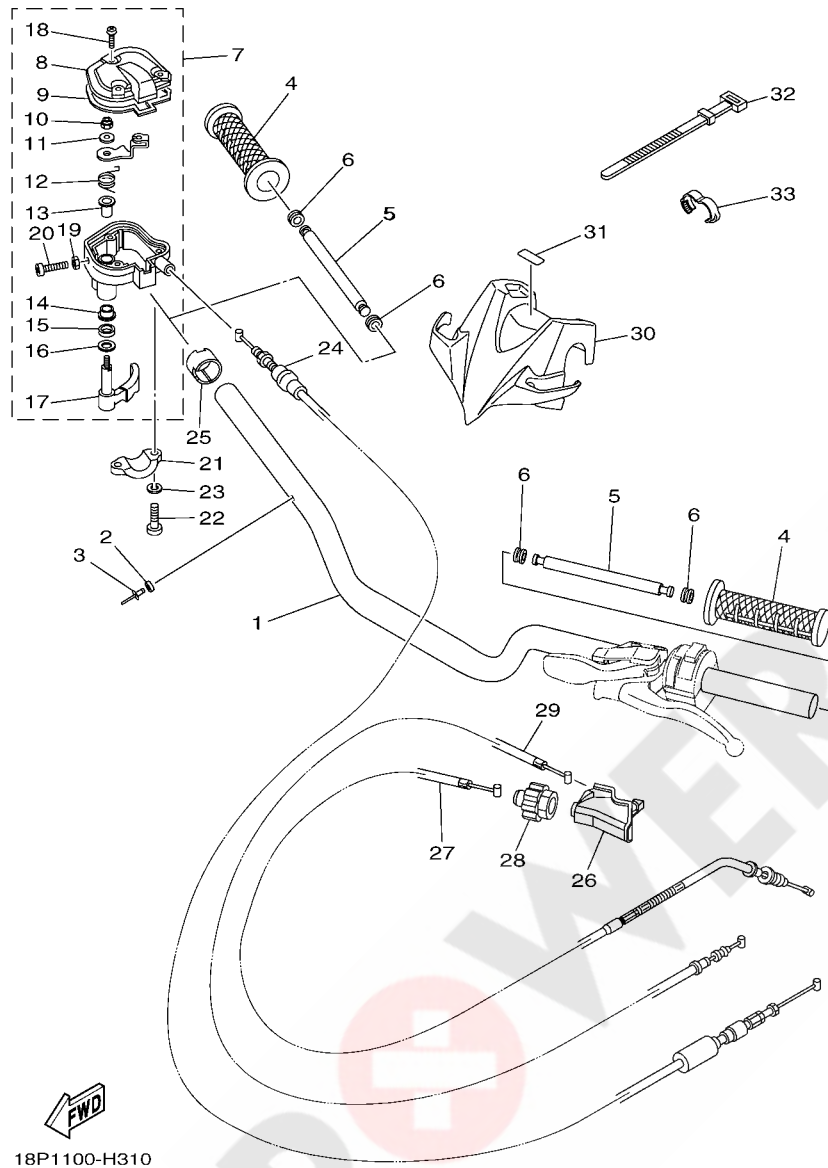
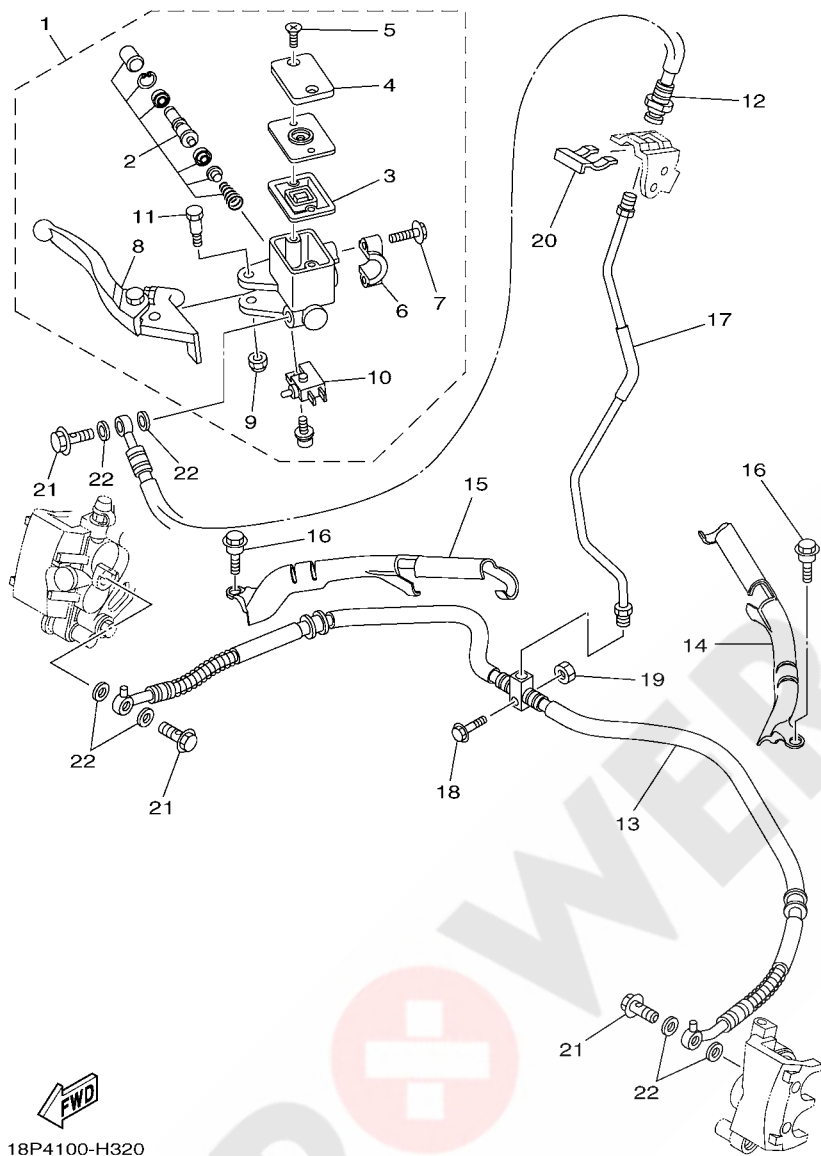


FIG. 31 STEERING HANDLE & CABLE

REF. NO.	PART NO.	DESCRIPTION	CAN	EUR	OCE	JPN	REMARKS
28	1C3-26342-50	BOOT, CABLE	1	1	1	1	
29	18P-26341-00	WIRE, BRAKE 1	1	1	1	1	
30	18P-26124-00	PROTECTOR, HANDLEBAR	1	1	1	1	
31	5D3-26219-10	EMBLEM	1	1	1	1	
32	437-83936-01	BAND, SWITCH CORD	2	2	2	2	
33	90464-16001	CLAMP	1	1	1	1	

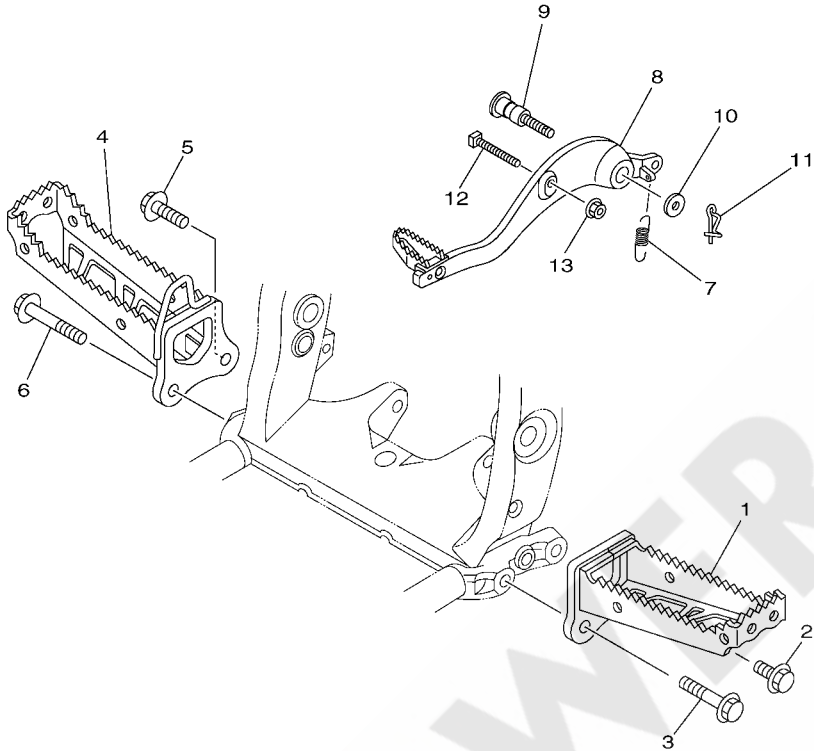


18P4100-H320

FIG. 32 FRONT MASTER CYLINDER

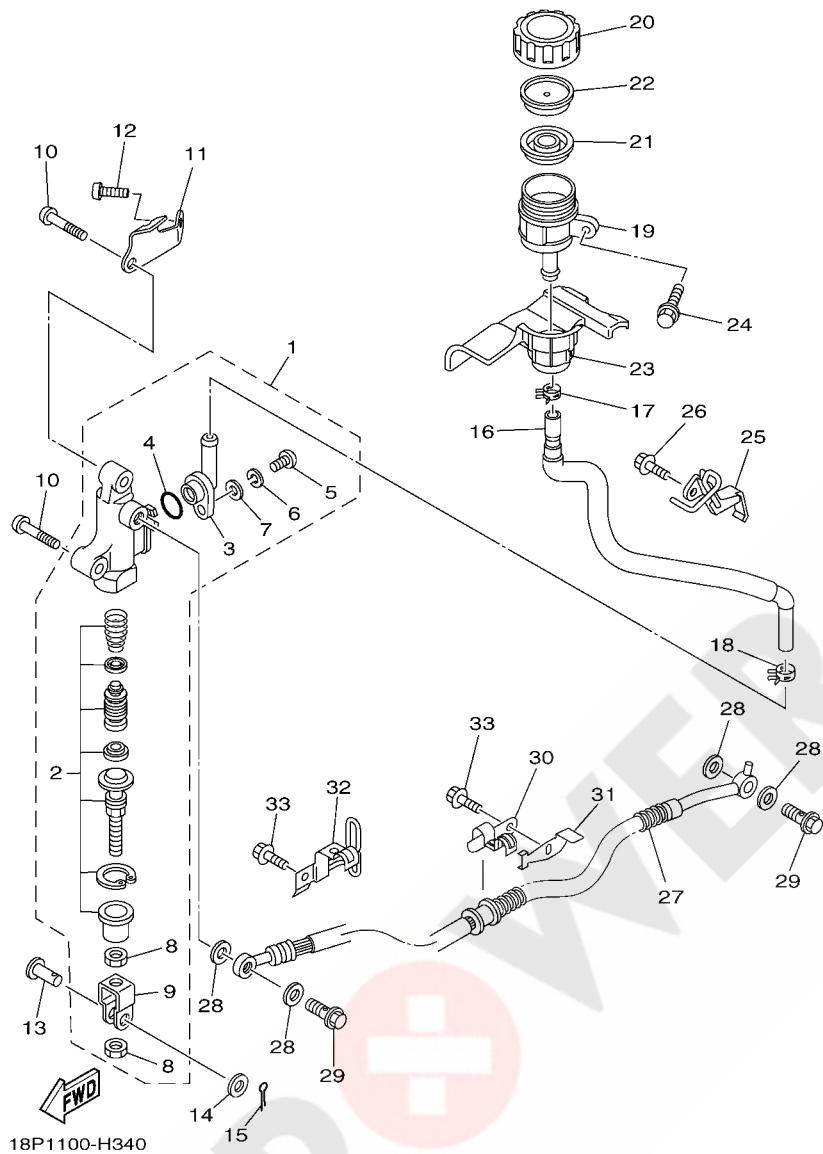
REF. NO.	PART NO.	DESCRIPTION	CAN	EUR	OC	JPN	REMARKS
1	5D3-2583T-00	MASTER CYLINDER ASSY	1	1	1	1	
2	5D3-W0041-00	.CYLINDER KIT, MASTER	1	1	1	1	
3	4TT-25854-00	.GASKET, DIAPHRAGM	1	1	1	1	
4	5D3-25852-00	.CAP, RESERVOIR	1	1	1	1	
5	4NK-2589H-00	.SCREW	2	2	2	2	
6	5LP-25867-00	.BRACKET, MASTER CYLINDER	1	1	1	1	
7	5MV-25833-00	.BOLT, FITTING	2	2	2	2	
8	5D3-83922-00	.LEVER 2	1	1	1	1	
9	95604-06100	.NUT, U	1	1	1	1	
10	5D3-83980-00	.FRONT STOP SWITCH ASSY	1	1	1	1	
11	3B4-2589F-00	.BOLT, LEVER	1	1	1	1	
12	18P-25872-10	HOSE, BRAKE 1	1	1	1	1	
13	18P-25873-10	HOSE, BRAKE 2	1	1	1	1	
14	18P-25875-00	HOLDER, BRAKE HOSE 1	1	1	1	1	
15	18P-25876-00	HOLDER, BRAKE HOSE 2	1	1	1	1	
16	90109-067F4	BOLT	2	2	2	2	
17	18P-25871-10	PIPE, BRAKE	1	1	1	1	
18	95822-06035	BOLT, FLANGE	1	1	1	1	
19	95312-06600	NUT	1	1	1	1	
20	2GU-25866-00	CIRCLIP	1	1	1	1	
21	90401-10015	BOLT, UNION	3	3	3	3	
22	90201-10118	WASHER, PLATE	6	6	6	6	

FIG. 33 STAND & FOOTREST



REF. NO.	PART NO.	DESCRIPTION	CAN	EUR	OCE	JPN	REMARKS
1	18P-27411-00	FOOTREST 1	1	1	1	1	
2	95812-12025	BOLT, FLANGE	1	1	1	1	
3	95812-12055	BOLT, FLANGE	1	1	1	1	
4	18P-27421-00	FOOTREST 2	1	1	1	1	
5	95812-12035	BOLT, FLANGE	1	1	1	1	
6	95812-12065	BOLT, FLANGE	1	1	1	1	
7	90506-25001	SPRING, TENSION	1	1	1	1	
8	18P-27211-00	PEDAL, BRAKE	1	1	1	1	
9	18P-27217-00	BOLT	1	1	1	1	
10	90201-08077	WASHER, PLATE	1	1	1	1	
11	90468-16191	CLIP	1	1	1	1	
12	90108-05001	BOLT, SQUARE	1	1	1	1	
13	95602-05200	NUT, SELF-LOCKING	1	1	1	1	

 18P1100-H330



18P1100-H340

FIG. 34 REAR MASTER CYLINDER

REF. NO.	PART NO.	DESCRIPTION	CAN	EUR	OCE	JPN	REMARKS
1	1S3-2580E-00	REAR MASTER CYLINDER ASSY	1	1	1	1	
2	1S3-W0042-50	.CYLINDER KIT, MASTER	1	1	1	1	
3	1AE-2582A-00	.JOINT	1	1	1	1	
4	93210-15620	.O-RING	1	1	1	1	
5	98506-04012	.SCREW, PAN HEAD	1	1	1	1	
6	92906-04100	.WASHER, SPRING	1	1	1	1	
7	92906-04600	.WASHER, PLATE	1	1	1	1	
8	4SS-27218-00	.NUT	2	2	2	2	
9	2YK-27222-00	.JOINT	1	1	1	1	
10	92012-08035	BOLT, BUTTON HEAD	2	2	2	2	
11	18P-27453-00	COVER 1	1	1	1	1	
12	92012-08012	BOLT, BUTTON HEAD	1	1	1	1	
13	90240-08124	PIN, CLEVIS	1	1	1	1	
14	90201-08083	WASHER, PLATE	1	1	1	1	
15	91401-16012	PIN, COTTER	1	1	1	1	
16	18P-25895-00	HOSE, RESERVOIR	1	1	1	1	
17	90467-11044	CLIP	1	1	1	1	
18	90467-14057	CLIP	1	1	1	1	
19	5JJ-25894-01	TANK, RESERVOIR	1	1	1	1	
20	3XP-25852-50	CAP, RESERVOIR	1	1	1	1	
21	2VN-25854-00	GASKET, DIAPHRAGM	1	1	1	1	
22	2VN-25855-00	BUSH,DIAPHRAGM	1	1	1	1	
23	18P-25897-00	DAMPER	1	1	1	1	
24	90119-06177	BOLT, WITH WASHER	1	1	1	1	
25	18P-27263-00	BRACKET 1	1	1	1	1	
26	95022-06012	BOLT, FLANGE	1	1	1	1	
27	18P-25874-00	HOSE, BRAKE	1	1	1	1	



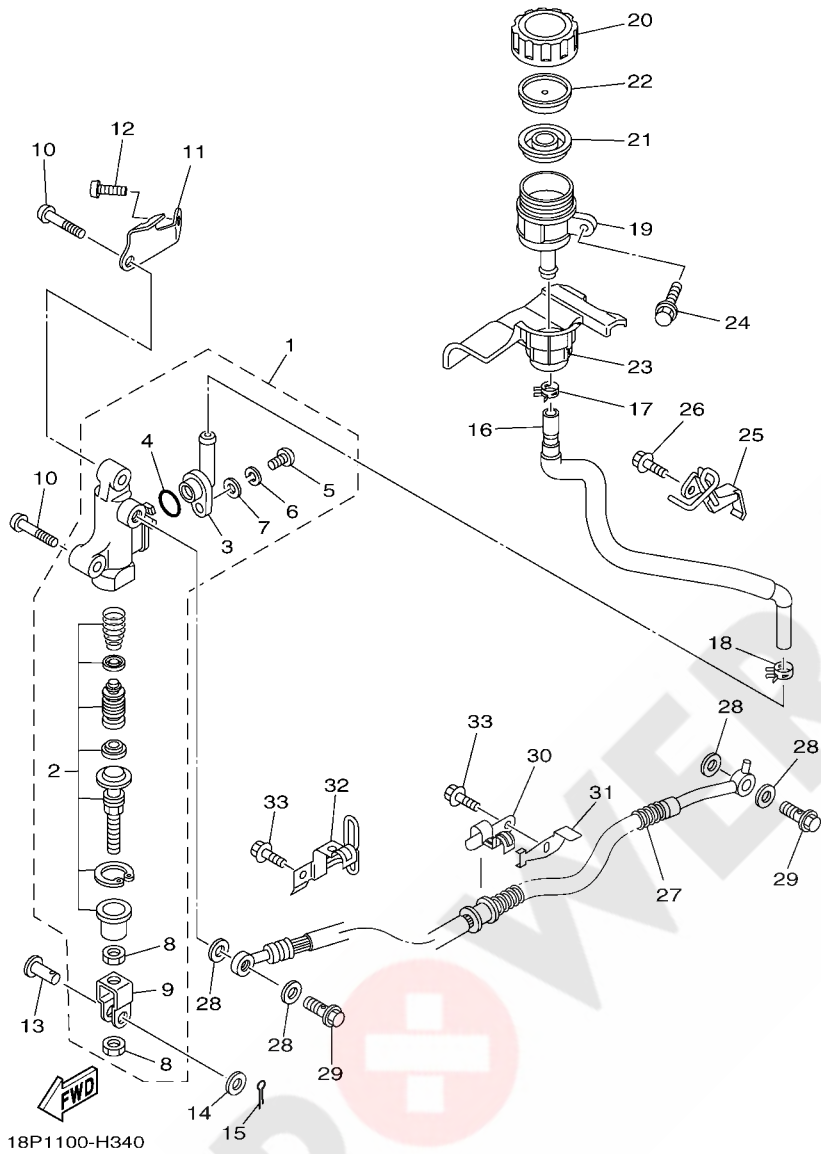
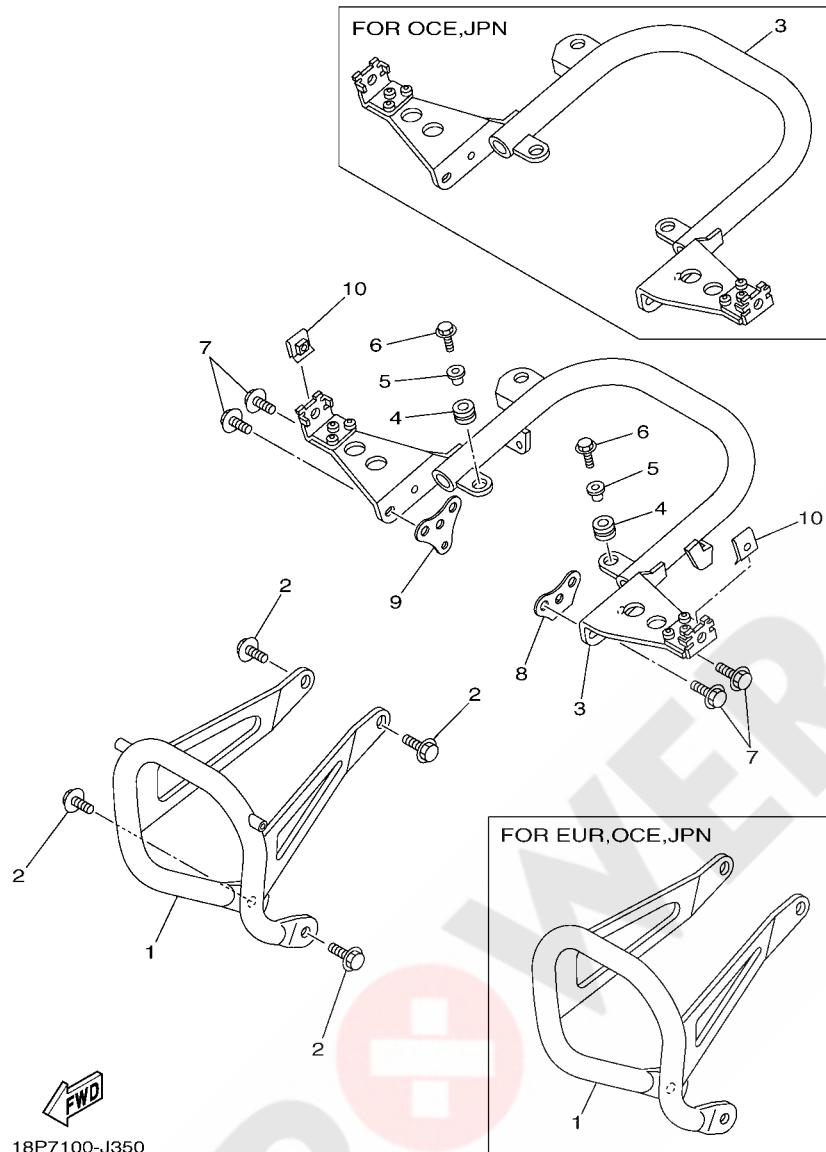


FIG. 34 REAR MASTER CYLINDER

REF. NO.	PART NO.	DESCRIPTION	CAN	EUR	OCE	JPN	REMARKS
28	90201-10118	WASHER, PLATE	4	4	4	4	
29	90401-10015	BOLT, UNION	2	2	2	2	
30	18P-25886-00	HOLDER, BRAKE HOSE	1	1	1	1	
31	18P-2743E-00	STOPPER	1	1	1	1	
32	18P-23317-00	HOLDER, CABLE	1	1	1	1	
33	90105-06063	BOLT, FLANGE	2	2	2	2	

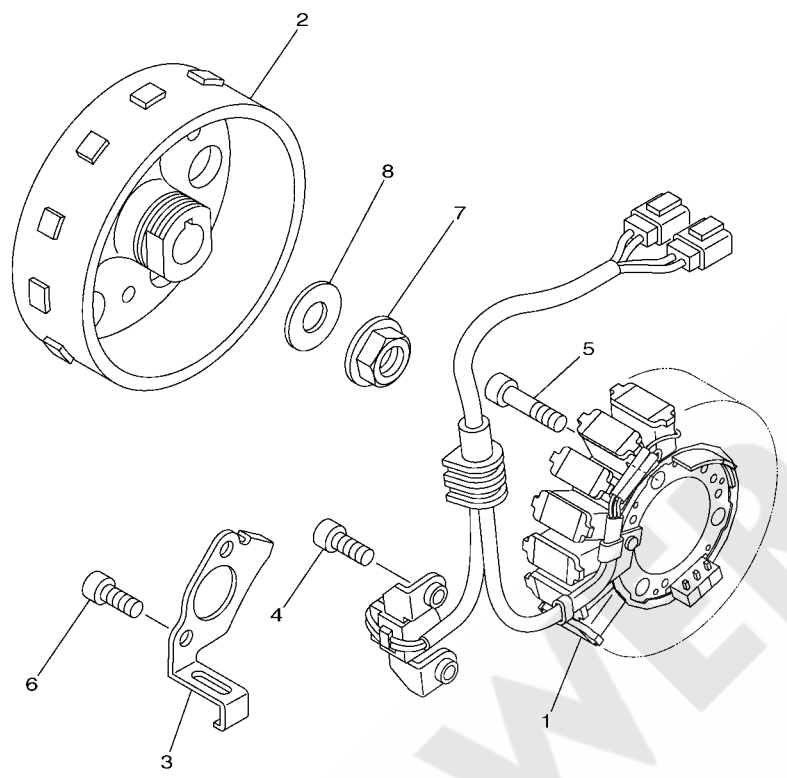


18P7100-J350

FIG. 35 GUARD

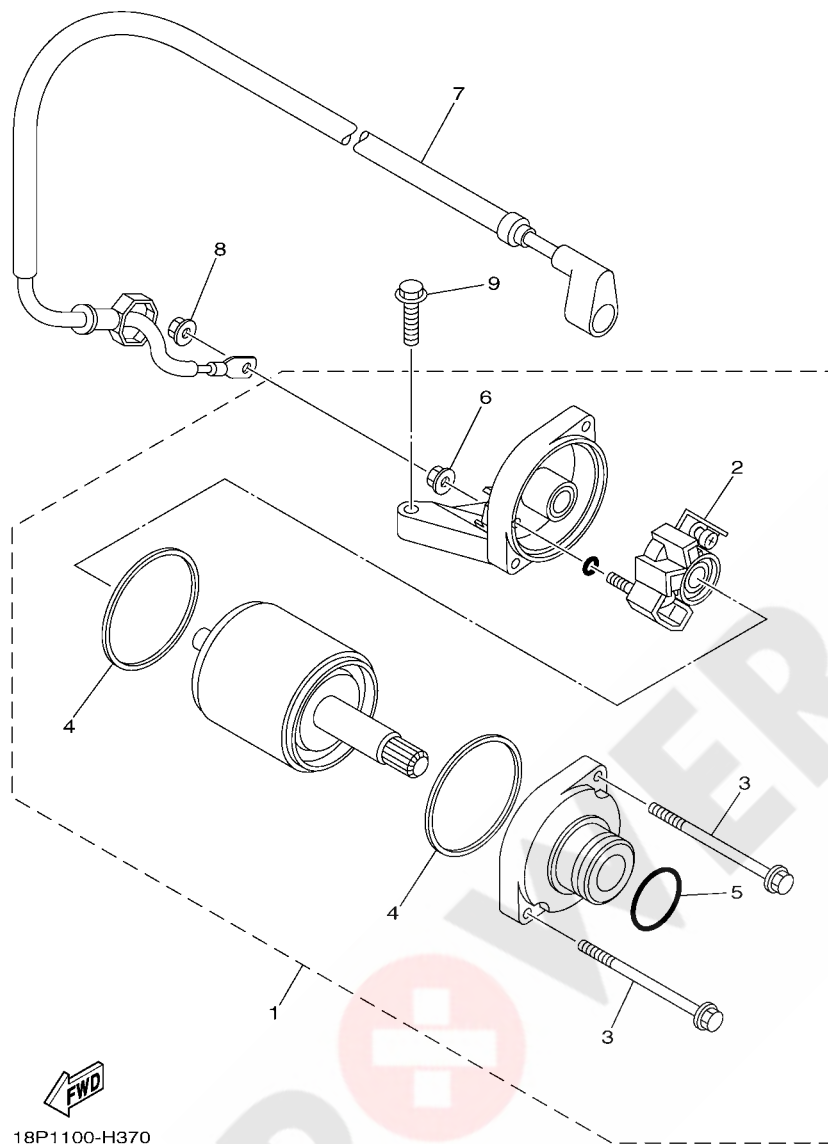
REF. NO.	PART NO.	DESCRIPTION	CAN	EUR	OCE	JPN	REMARKS
1	18P-2845N-10	BAR, CARRY FRONT	1				
	18P-2845N-00	BAR, CARRY FRONT		1	1	1	
2	95812-08020	BOLT, FLANGE	4	4	4	4	
3	18P-2845R-10	BAR, CARRY REAR	1	1			
	18P-2845R-00	BAR, CARRY REAR			1	1	
4	90480-10289	GROMMET	2	2	2	2	
5	90387-06063	COLLAR	2	2	2	2	
6	95812-06020	BOLT, FLANGE	2	2	2	2	
7	95812-08020	BOLT, FLANGE	4	4	4	4	
8	5TG-28215-00	WASHER, SPECIAL	1	1	1	1	
9	18P-28215-00	WASHER, SPECIAL	1	1	1	1	
10	90183-061A5	NUT, SPRING	2	2	2	2	

**FIG. 36 GENERATOR**



  
18P1100-H360

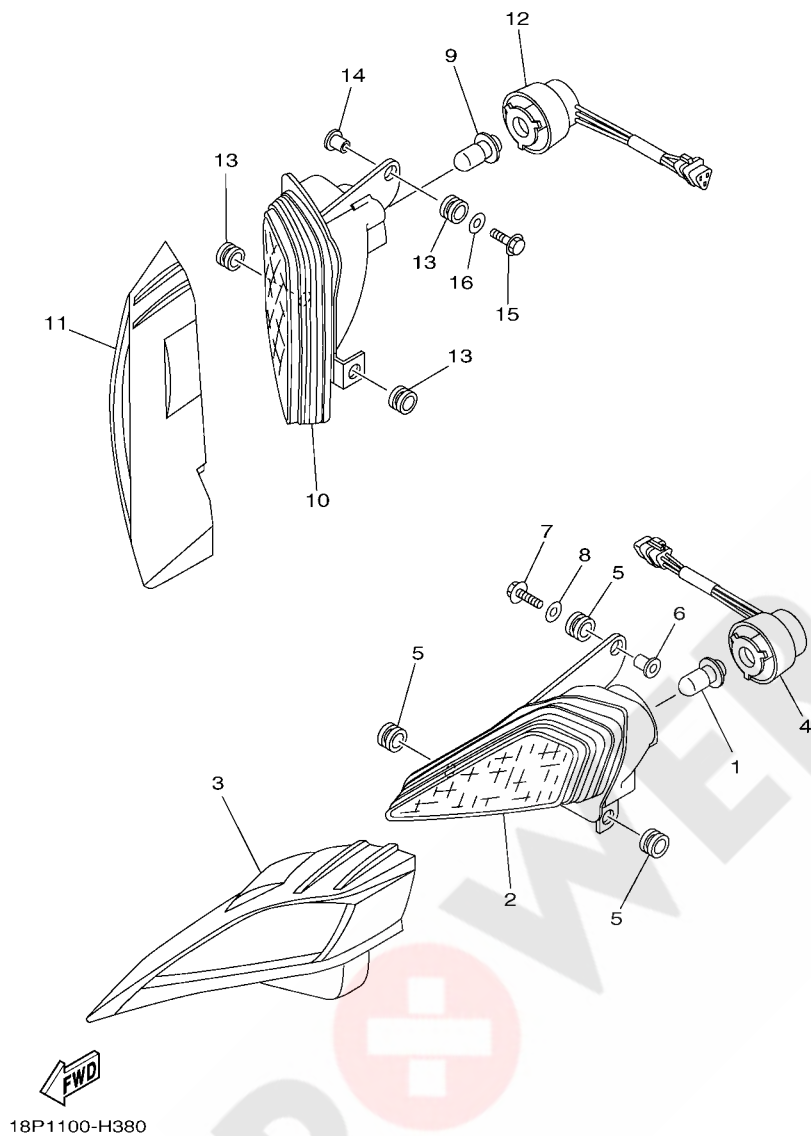
REF. NO.	PART NO.	DESCRIPTION	CAN	EUR	OCE	JPN	REMARKS
1	18P-81410-00	STATOR ASSY	1	1	1	1	
2	18P-81450-00	ROTOR ASSY	1	1	1	1	
3	18P-81528-00	CLAMP 1	1	1	1	1	
4	90110-06168	BOLT, HEXAGON SOCKET HEAD	2	2	2	2	
5	90110-06169	BOLT, HEXAGON SOCKET HEAD	3	3	3	3	
6	90110-06168	BOLT, HEXAGON SOCKET HEAD	2	2	2	2	
7	90179-12657	NUT	1	1	1	1	
8	90201-12020	WASHER, PLATE	1	1	1	1	



18P1100-H370

FIG. 37 STARTING MOTOR

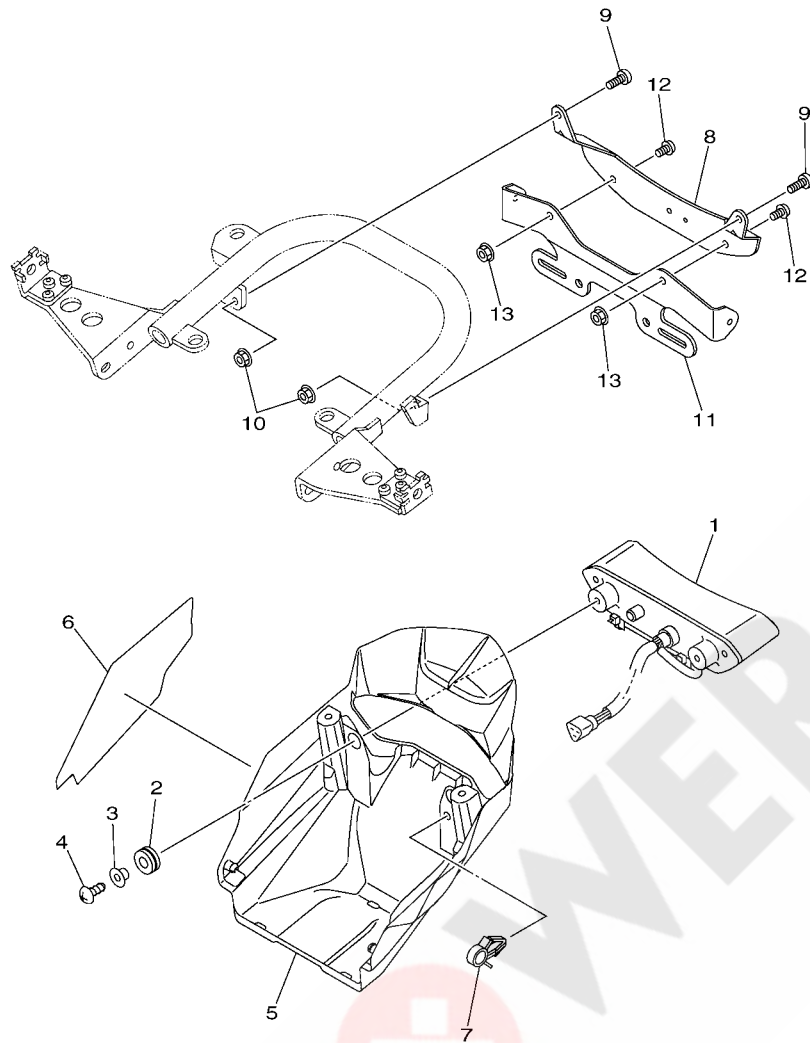
REF. NO.	PART NO.	DESCRIPTION	CAN	EUR	OCE	JPN	REMARKS
1	18P-81890-00	MOTOR ASSY	1	1	1	1	
2	18P-81801-00	.BRUSH SET	1	1	1	1	
3	18P-81826-00	.BOLT	2	2	2	2	
4	4B5-81844-00	.GASKET	2	2	2	2	
5	1FK-81847-00	.O-RING	1	1	1	1	
6	4XV-8182A-00	.NUT	1	1	1	1	
7	18P-81815-00	CORD, STARTER MOTOR	1	1	1	1	
8	4XV-8182A-00	NUT	1	1	1	1	
9	95022-06025	BOLT, FLANGE	2	2	2	2	



18P1100-H380

FIG. 38 HEADLIGHT

REF. NO.	PART NO.	DESCRIPTION	CAN	EUR	OCE	JPN	REMARKS
1	4KB-84314-01	BULB (12V-30/30W)	1	1	1	1	
2	5TG-84110-03	HEADLIGHT UNIT ASSY	1	1	1	1	
3	18P-84165-00	RIM, HEADLIGHT COVER 1	1	1	1	1	
4	5TG-84140-01	SOCKET CORD ASSY	1	1	1	1	
5	90480-14102	GROMMET	3	3	3	3	
6	90387-06136	COLLAR	1	1	1	1	
7	95802-06025	BOLT, FLANGE	1	1	1	1	
8	90201-06078	WASHER, PLATE	1	1	1	1	
9	4KB-84314-01	BULB (12V-30/30W)	1	1	1	1	
10	5TG-84310-03	HEADLIGHT UNIT ASSY	1	1	1	1	
11	18P-84166-00	RIM, HEADLIGHT COVER 2	1	1	1	1	
12	5TG-84340-01	SOCKET CORD ASSY 1	1	1	1	1	
13	90480-14102	GROMMET	3	3	3	3	
14	90387-06136	COLLAR	1	1	1	1	
15	95802-06025	BOLT, FLANGE	1	1	1	1	
16	90201-06078	WASHER, PLATE	1	1	1	1	



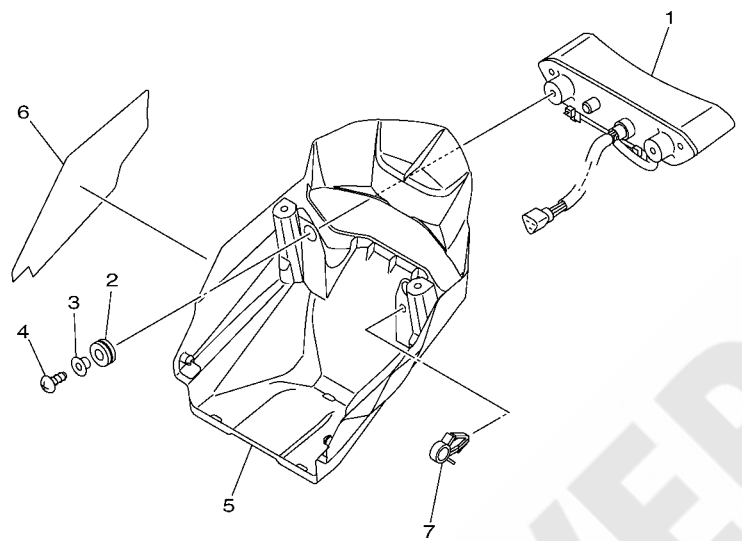
18P1100-H390

FIG. 39 TAILLIGHT

REF. NO.	PART NO.	DESCRIPTION	CAN	EUR	OCE	JPN	REMARKS
1	1S3-84710-01	TAILLIGHT UNIT ASSY	1	1			
2	90480-14323	GROMMET	2	2			
3	90387-06204	COLLAR	2	2			
4	97702-50025	SCREW, TAPPING	2	2			
5	18P-84716-00	COVER, TAILLIGHT	1	1			
6	18P-8411K-00	PLATE, INSULATOR	1	1			
7	90464-15157	CLAMP	1	1			
8	18P-84703-00	BRACKET	1	1			
9	90111-06059	BOLT, HEX. SOCKET BUTTON	2	2			
10	95602-06200	NUT, SELF-LOCKING	2	2			
11	18P-84751-00	BRACKET, LICENSE	1				
12	92012-06012	BOLT, BUTTON HEAD	2				
13	95602-06200	NUT, SELF-LOCKING	2				

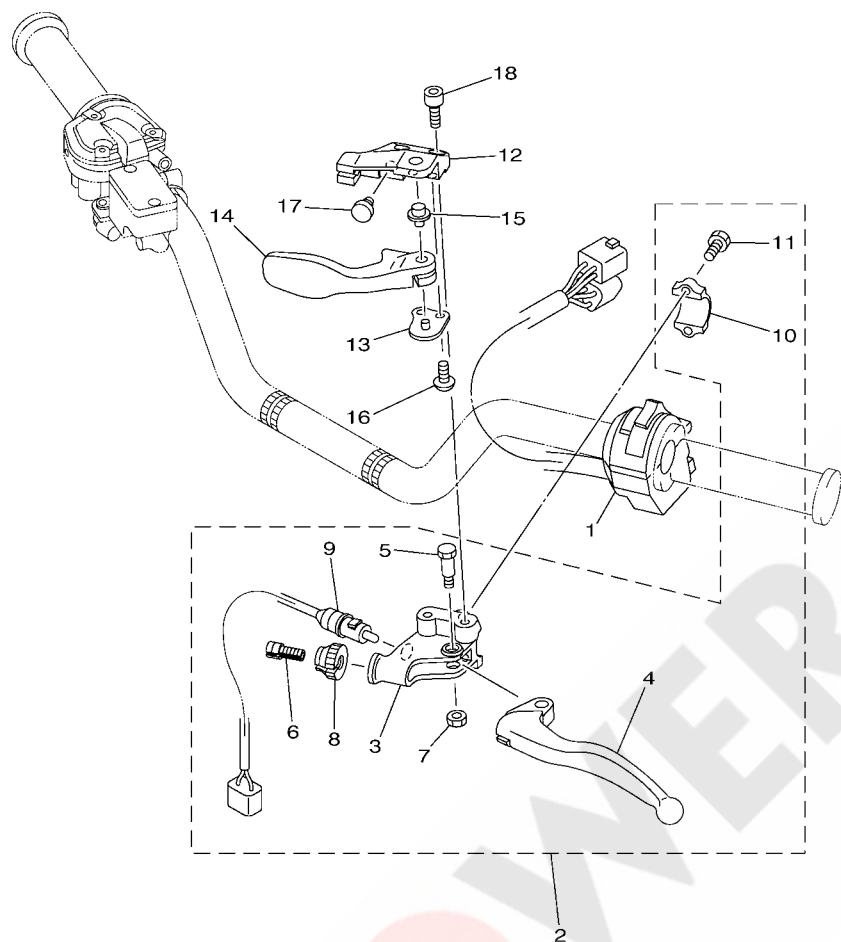
**FIG. 40 TAILLIGHT 2**

REF. NO.	PART NO.	DESCRIPTION	CAN	EUR	OCE	JPN	REMARKS
1	1S3-84710-01	TAILLIGHT UNIT ASSY			1	1	
2	90480-14323	GROMMET			2	2	
3	90387-06204	COLLAR			2	2	
4	97702-50025	SCREW, TAPPING			2	2	
5	18P-84716-00	COVER, TAILLIGHT			1	1	
6	18P-8411K-00	PLATE, INSULATOR			1	1	
7	90464-15157	CLAMP			1	1	



**FWD**  
18P1100-H400

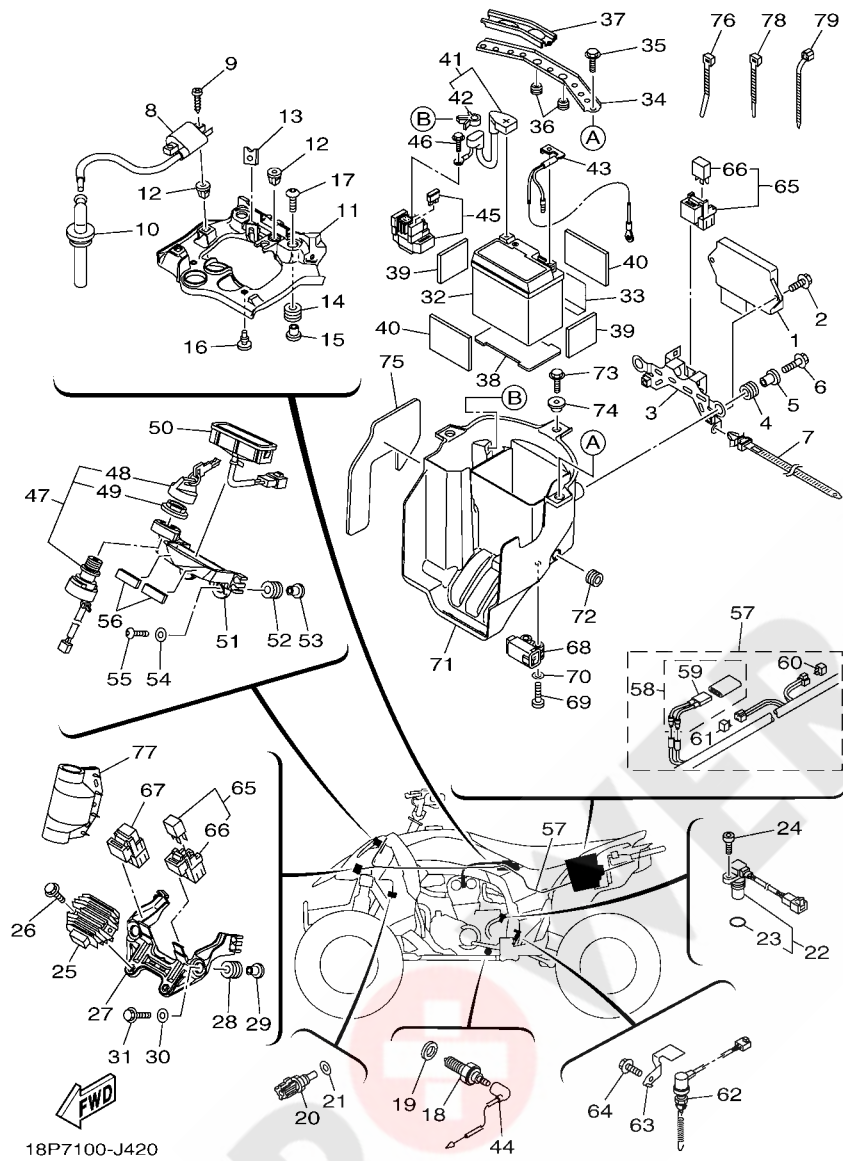
FIG. 41 HANDLE SWITCH & LEVER



REF. NO.	PART NO.	DESCRIPTION	CAN	EUR	OCE	JPN	REMARKS
1	1S3-83973-11	SWITCH, HANDLE 3	1	1	1	1	
2	18P-82910-00	LEVER HOLDER ASSY (LEFT)	1	1	1	1	
3	5TG-82911-00	.HOLDER, LEVER 1	1	1	1	1	
4	5TJ-83912-00	.LEVER 1	1	1	1	1	
5	90109-06034	.BOLT	1	1	1	1	
6	5TA-26337-00	.BOLT, ADJUSTING	1	1	1	1	
7	95602-06100	.NUT, U	1	1	1	1	
8	5HD-83951-00	.BOLT, CABLE ADJUSTING	1	1	1	1	
9	5KM-82917-00	.SWITCH	1	1	1	1	
10	5TG-82913-00	.HOLDER, LEVER LOWER 1	1	1	1	1	
11	90101-05033	.BOLT	2	2	2	2	
12	5TG-25727-00	BRACKET, LEVER	1	1	1	1	
13	5D3-25689-00	PLATE, GUIDE	1	1	1	1	
14	5TG-25726-00	LEVER, BRAKE	1	1	1	1	
15	5TG-83923-00	COLLAR, LEVER 2	1	1	1	1	
16	92012-06014	BOLT, BUTTON HEAD	2	2	2	2	
17	90338-07007	PLUG	1	1	1	1	
18	92014-06016	BOLT, BUTTON HEAD	2	2	2	2	

  
18P1100-H410

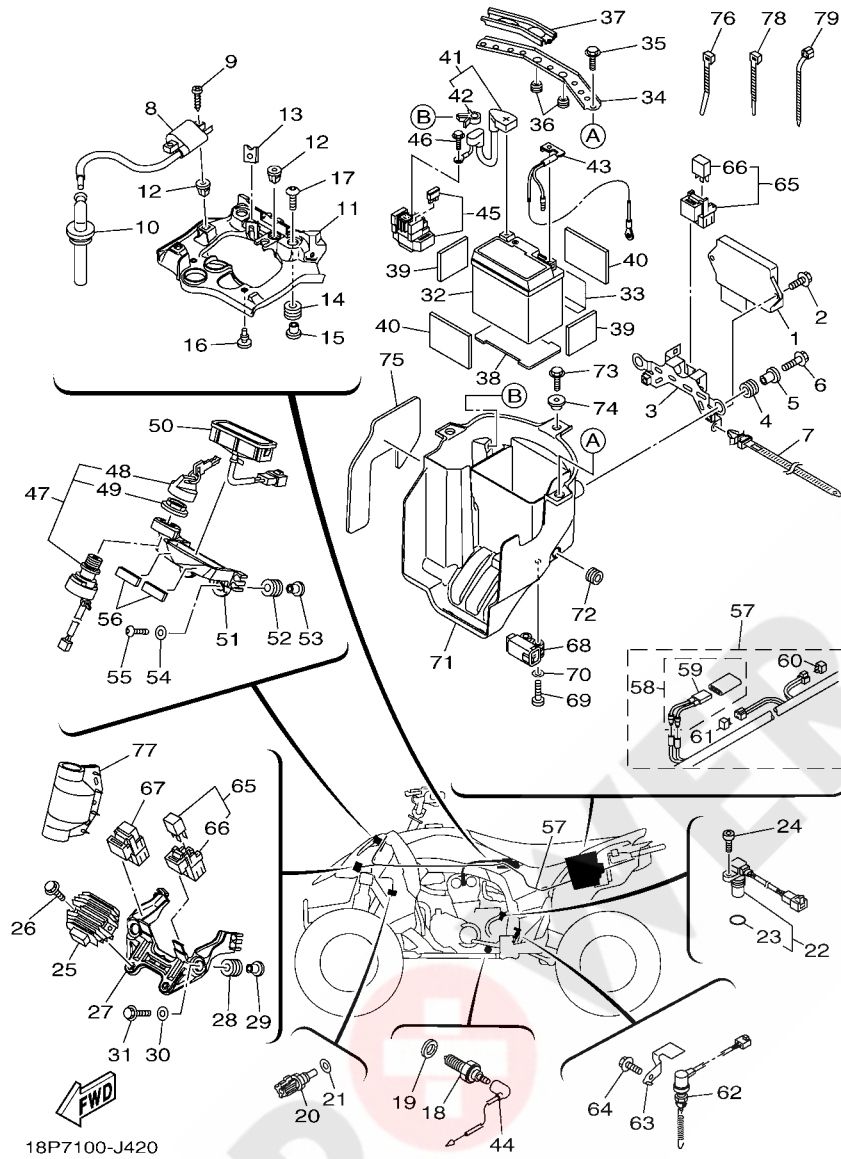




18P7100-J420

FIG. 42 ELECTRICAL 1

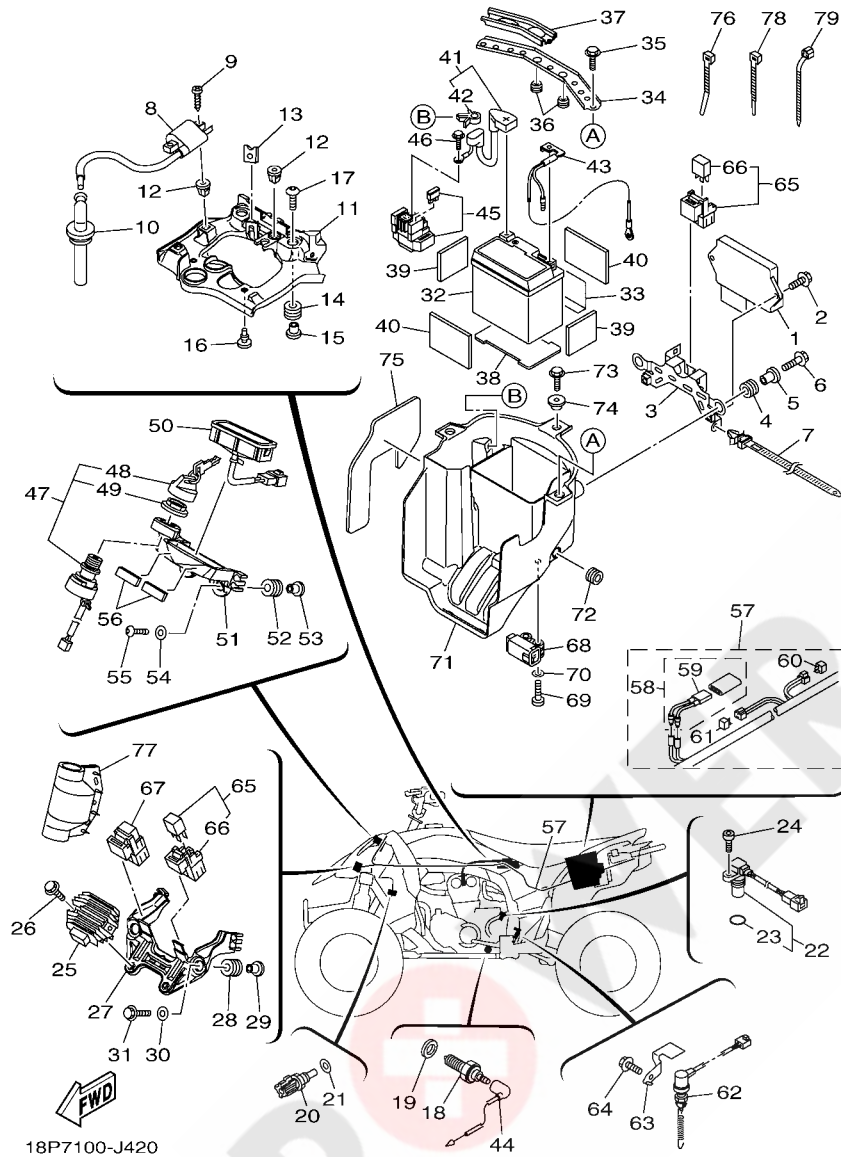
REF. NO.	PART NO.	DESCRIPTION	CAN	EUR	OCE	JPN	REMARKS
1	18P-8591A-10	ENGINE CONTROL UNIT ASSY	1	1	1	1	
2	95812-06016	BOLT, FLANGE	2	2	2	2	
3	18P-85991-00	BRACKET, UNIT	1	1	1	1	
4	90480-14011	GROMMET	2	2	2	2	
5	90387-06388	COLLAR	2	2	2	2	
6	95812-06020	BOLT, FLANGE	2	2	2	2	
7	90464-12036	CLAMP	1	1	1	1	
8	18P-82310-00	IGNITION COIL ASSY	1	1	1	1	
9	97702-60125	SCREW, TAPPING	2	2	2	2	
10	18P-82370-00	PLUG CAP ASSY	1	1	1	1	
11	18P-81948-00	BRACKET	1	1	1	1	
12	90338-08226	PLUG	3	3	3	3	
13	90183-060A6	NUT, SPRING	1	1	1	1	
14	90480-14323	GROMMET	2	2	2	2	
15	90387-06161	COLLAR	2	2	2	2	
16	90338-05008	PLUG	2	2	2	2	
17	90111-06084	BOLT, HEX. SOCKET BUTTON	2	2	2	2	
18	3GB-82540-01	NEUTRAL SWITCH ASSY	1	1	1	1	
19	90430-10148	GASKET	1	1	1	1	
20	8CC-85790-01	THERMOSENSOR ASSY	1	1	1	1	
21	90430-12202	GASKET	1	1	1	1	
22	18P-83755-00	SENSOR, SPEED	1	1	1	1	
23	4D9-81168-00	.O-RING	1	1	1	1	
24	91312-06016	BOLT	1	1	1	1	
25	5BN-81960-00	RECTIFIER & REGULATOR ASSY	1	1	1	1	
26	95802-06020	BOLT, FLANGE	2	2	2	2	
27	18P-87208-00	STAY, REGULATOR	1	1	1	1	



18P7100-J420

FIG. 42 ELECTRICAL 1

REF. NO.	PART NO.	DESCRIPTION	CAN	EUR	OCE	JPN	REMARKS
28	90480-10289	GROMMET	2	2	2	2	
29	90387-06204	COLLAR	2	2	2	2	
30	90201-06078	WASHER, PLATE	2	2	2	2	
31	95802-06025	BOLT, FLANGE	2	2	2	2	
32	1S4-82100-10	BATTERY ASSY (YTZ7S)	1	1	1		
	5XT-82100-00	BATTERY ASSY (YTZ7S)				1	
33	18P-82122-00	SEAT, BATTERY	1	1	1	1	
34	18P-82128-00	BRACKET, BATTERY	1	1	1	1	
35	90105-06084	BOLT, FLANGE	2	2	2	2	
36	90338-12192	PLUG	2	2	2	2	
37	18P-82129-00	COVER, BATTERY	1	1	1	1	
38	4D3-82122-00	SEAT, BATTERY	1	1	1	1	
39	5MP-21747-00	DAMPER	2	2	2	2	
40	4HC-27415-00	PLATE, FOOTREST	2	2	2	2	
41	18P-W8211-10	WIRE, PLUS LEAD	1	1	1	1	
42	90464-12001	.CLAMP	1	1	1	1	
43	18P-82116-00	WIRE, MINUS LEAD	1	1	1	1	
44	18P-82541-00	WIRE, LEAD	1	1	1	1	
45	18P-81940-00	STARTER RELAY ASSY	1	1	1	1	
46	95022-06008	BOLT, FLANGE	2	2	2	2	
47	4SH-82510-00	MAIN SWITCH ASSY	1	1	1	1	
48	3HN-82579-00	.CAP, KEY	1	1	1	1	
49	3HN-82569-00	.NUT, MAIN SWITCH	1	1	1	1	
50	18P-83530-00	PILOT LIGHT ASSY	1	1	1	1	
51	18P-8361L-00	BRACKET, INDICATOR	1	1	1	1	
52	90480-10289	GROMMET	2	2	2	2	
53	90387-06204	COLLAR	2	2	2	2	

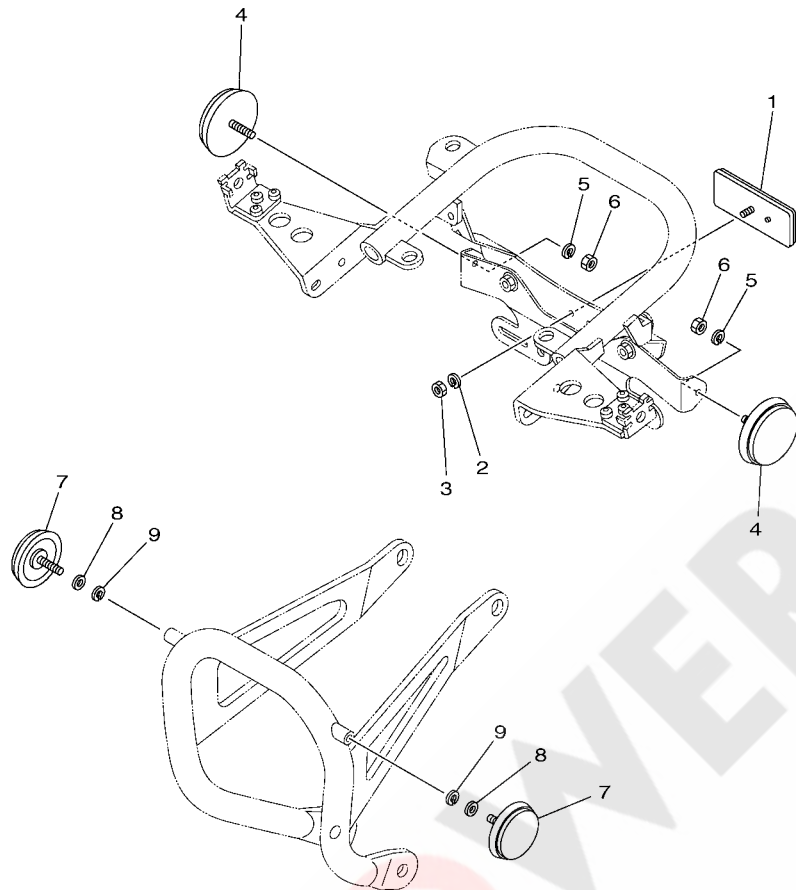


18P7100-J420

FIG. 42 ELECTRICAL 1

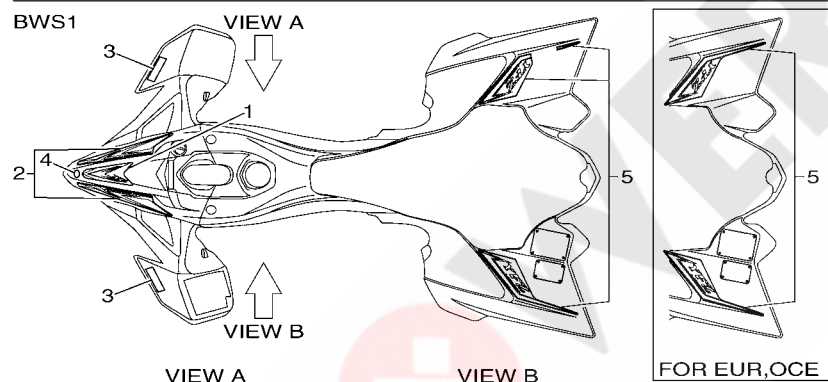
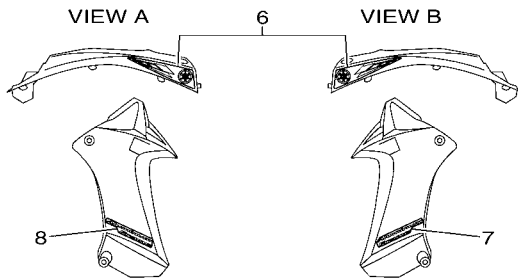
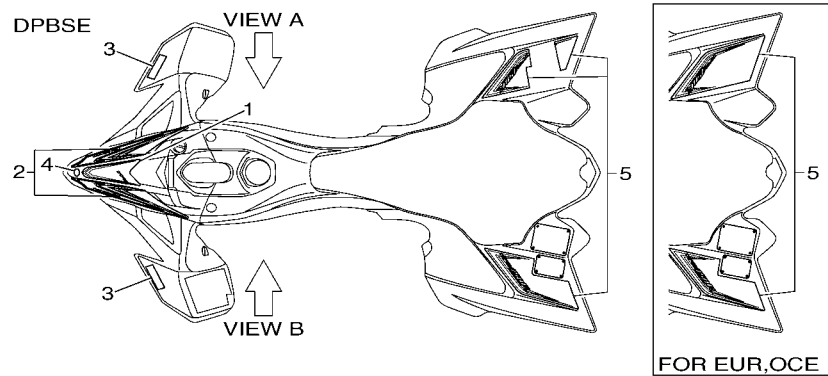
REF. NO.	PART NO.	DESCRIPTION	CAN	EUR	OC	JPN	REMARKS
54	90201-06078	WASHER, PLATE	2	2	2	2	
55	92012-06025	BOLT, BUTTON HEAD	2	2	2	2	
56	2C0-28372-00	DAMPER	2	2	2	2	
57	18P-82590-00	WIRE HARNESS ASSY	1				
	18P-82590-10	WIRE HARNESS ASSY		1	1	1	
58	5ND-82180-00	.CIRCUIT BREAKER ASSY	1	1	1	1	
59	5ND-82560-00	..THERMO SWITCH ASSY	1	1	1	1	
60	4WA-81980-00	.DIODE ASSY	1	1	1	1	
61	3WP-81980-00	.DIODE ASSY	1	1	1	1	
62	18P-82530-00	STOP SWITCH ASSY	1	1	1	1	
63	18P-8246B-00	COVER 1	1	1	1	1	
64	95022-06010	BOLT, FLANGE	1	1	1	1	
65	5EA-81950-20	RELAY ASSY	2	2	2	2	
66	5EA-81952-00	.HOLDER, RELAY	1	1	1	1	
67	5DM-81950-00	RELAY ASSY (G8HN-1C4T-DJ-Y52)	1	1	1	1	
68	5PS-82576-01	SENSOR, LEAN ANGLE	1	1	1	1	
69	91312-04025	BOLT	2	2	2	2	
70	90201-04030	WASHER, PLATE	2	2	2	2	
71	18P-8212B-00	BOX, BATTERY 1	1	1	1	1	
72	90480-12007	GROMMET	2	2	2	2	
73	90105-06084	BOLT, FLANGE	1	1	1	1	
74	90387-06153	COLLAR	1	1	1	1	
75	18P-8254E-00	INSULATOR	1	1	1	1	
76	90465-10098	CLAMP	1	1	1	1	
77	5RU-8252U-00	COVER	1	1	1	1	
78	90465-13M11	CLAMP	1	1	1	1	
79	90464-13073	CLAMP	2	2	2	2	

FIG. 43 ELECTRICAL 2



**FWD**  
18P1100-H430

REF. NO.	PART NO.	DESCRIPTION	CAN	EUR	OCE	JPN	REMARKS
1	3Y6-85130-02	REAR REFLECTOR ASSY	1	1			
2	92902-05100	WASHER, SPRING	1	1			
3	95302-05600	NUT	1	1			
4	449-85131-02	REFLECTOR, REAR 1	2				
5	92902-05100	WASHER, SPRING	2				
6	95302-05600	NUT	2				
7	2EK-85111-00	REFLECTOR, FRONT 1	2				
8	92902-05200	WASHER	2				
9	92902-05100	WASHER, SPRING	2				



18P7100-J440

FIG. 44 GRAPHICS

REF. NO.	PART NO.	DESCRIPTION	CAN	EUR	OCE	JPN	REMARKS
1	18P-21569-30	GRAPHIC, 1	1	1	1	1	UR FOR DPBSE
	18P-21569-40	GRAPHIC, 1	1	1	1		UR FOR BWS1
2	18P-2159A-30	GRAPHIC SET 1	1	1	1	1	UR FOR DPBSE
	18P-2159A-40	GRAPHIC SET 1	1	1	1		UR FOR BWS1
3	4ES-2153E-40	EMBLEM, YAMAHA	2	2	2	2	UR FOR DPBSE
	4ES-2153E-20	EMBLEM, YAMAHA	2	2	2		UR FOR BWS1
4	4KN-2836B-10	TUNING FORK MARK	1	1	1	1	
5	18P-2165A-70	GRAPHIC SET,REAR FENDER	1			1	UR FOR DPBSE
	18P-2165A-90	GRAPHIC SET,REAR FENDER	1				UR FOR BWS1
	18P-2165A-60	GRAPHIC SET,REAR FENDER		1	1		UR FOR DPBSE
	18P-2165A-80	GRAPHIC SET,REAR FENDER		1	1		UR FOR BWS1
6	18P-2173L-00	GRAPHIC SET 1	1	1	1	1	UR FOR DPBSE
	18P-2173L-20	GRAPHIC SET 1	1	1	1		UR FOR BWS1
7	18P-21781-10	EMBLEM 1	1	1	1	1	FOR DPBSE
8	18P-21782-10	EMBLEM 2	1	1	1	1	FOR DPBSE

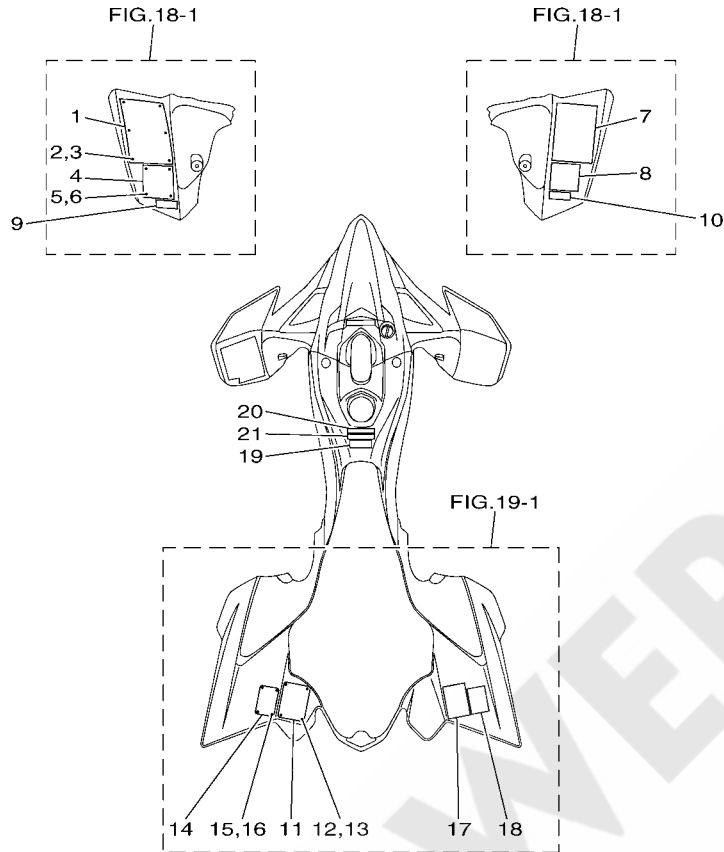


FIG. 45 EMBLEM & LABEL 1

REF. NO.	PART NO.	DESCRIPTION	CAN	EUR	OCE	JPN	REMARKS
1	5FE-21568-01	LABEL, WARNING	1				ENGLISH
2	90267-32004	RIVET, BLIND	6				
3	90201-03008	WASHER, PLATE	6				
4	4D3-2816L-00	LABEL, WARNING AGE	1				ENGLISH
5	90267-32004	RIVET, BLIND	4				
6	90201-03008	WASHER, PLATE	4				
7	4WU-21568-10	LABEL, WARNING	1				FRENCH
8	4D3-2816L-10	LABEL, WARNING AGE	1				FRENCH
9	4D3-2817J-00	PLATE, ANSI SVIA	1				ENGLISH
10	4D3-2817J-10	PLATE, ANSI SVIA	1				FRENCH
11	5D3-2816M-00	LABEL, WARNING TIRE & LOAD	1				ENGLISH
12	90267-32004	RIVET, BLIND	4				
13	90201-03008	WASHER, PLATE	4				
14	5FE-2151H-01	LABEL 5	1				ENGLISH
15	90267-32004	RIVET, BLIND	4				
16	90201-03008	WASHER, PLATE	4				
17	5D3-2816M-10	LABEL, WARNING TIRE & LOAD	1				FRENCH
18	4WU-2151H-10	LABEL 5	1				FRENCH
19	4SH-2416E-00	LABEL, CAUTION CANADA	1				ENGLISH
20	5PW-2415E-11	LABEL, CAUTION	1				ENGLISH
21	5PW-2415E-31	LABEL, CAUTION	1				FRENCH

18P1100-H450

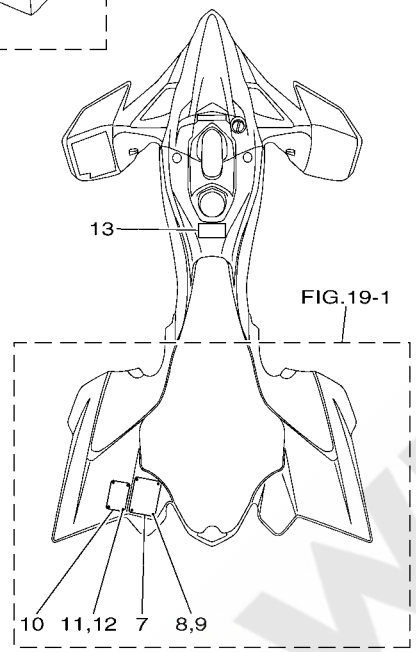
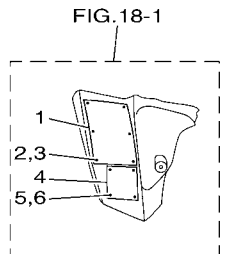


FIG. 46 EMBLEM & LABEL 2

REF. NO.	PART NO.	DESCRIPTION	CAN	EUR	OCE	JPN	REMARKS
1	43P-2816R-00	LABEL, WARNING GENERAL INFO.		1			
2	90267-32004	RIVET, BLIND		6			
3	90201-03008	WASHER, PLATE		6			
4	4D3-2816L-20	LABEL, WARNING AGE		1			
5	90267-32004	RIVET, BLIND		4			
6	90201-03008	WASHER, PLATE		4			
7	5D3-2816M-M0	LABEL, WARNING TIRE & LOAD		1			
8	90267-32004	RIVET, BLIND		4			
9	90201-03008	WASHER, PLATE		4			
10	1AS-2816P-00	LABEL, WARNING PASSENGER		1			
11	90267-32004	RIVET, BLIND		4			
12	90201-03008	WASHER, PLATE		4			
13	5TG-2415E-00	LABEL, CAUTION		1			

18P1100-H460

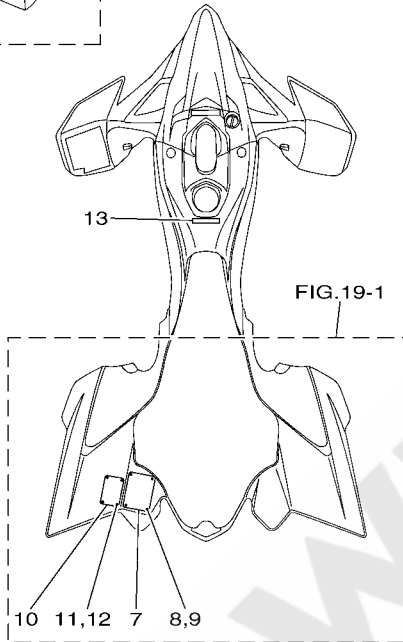
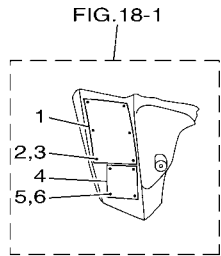


FIG. 47 EMBLEM & LABEL 3

REF. NO.	PART NO.	DESCRIPTION	CAN	EUR	OCE	JPN	REMARKS
1	5FE-21568-11	LABEL, WARNING			1		ENGLISH
2	90267-32004	RIVET, BLIND			6		
3	90201-03008	WASHER, PLATE			6		
4	4D3-2816L-00	LABEL, WARNING AGE			1		ENGLISH
5	90267-32004	RIVET, BLIND			4		
6	90201-03008	WASHER, PLATE			4		
7	5D3-2816M-00	LABEL, WARNING TIRE & LOAD			1		ENGLISH
8	90267-32004	RIVET, BLIND			4		
9	90201-03008	WASHER, PLATE			4		
10	5FE-2151H-01	LABEL 5			1		ENGLISH
11	90267-32004	RIVET, BLIND			4		
12	90201-03008	WASHER, PLATE			4		
13	5TG-2415E-10	LABEL, CAUTION			1		ENGLISH

18P1100-H470



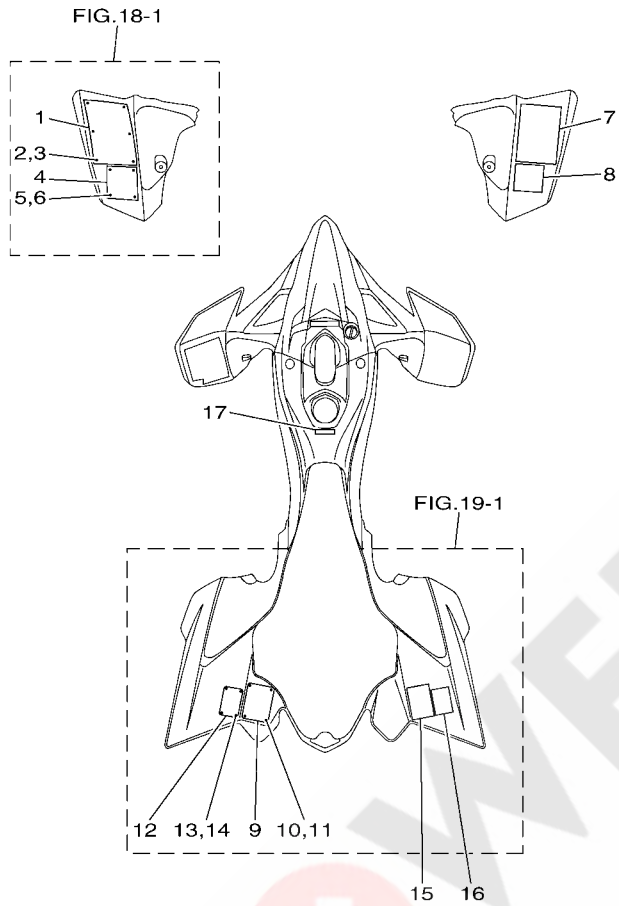


FIG. 48 EMBLEM & LABEL 4

REF. NO.	PART NO.	DESCRIPTION	CAN	EUR	OCE	JPN	REMARKS
1	5FE-21568-11	LABEL, WARNING				1	ENGLISH
2	90267-32004	RIVET, BLIND				6	
3	90201-03008	WASHER, PLATE				6	
4	4D3-2816L-00	LABEL, WARNING AGE				1	ENGLISH
5	90267-32004	RIVET, BLIND				4	
6	90201-03008	WASHER, PLATE				4	
7	4SH-21568-00	LABEL, WARNING				1	JAPANESE
8	4SH-21697-00	LABEL, CAUTION 2				1	JAPANESE
9	5D3-2816M-00	LABEL, WARNING TIRE & LOAD				1	ENGLISH
10	90267-32004	RIVET, BLIND				4	
11	90201-03008	WASHER, PLATE				4	
12	5FE-2151H-01	LABEL 5				1	ENGLISH
13	90267-32004	RIVET, BLIND				4	
14	90201-03008	WASHER, PLATE				4	
15	5D3-2816M-20	LABEL, WARNING TIRE & LOAD				1	JAPANESE
16	4LB-2151H-02	LABEL 5				1	JAPANESE
17	3FB-2415E-C1	LABEL, CAUTION				1	JAPANESE

18P7100-J480

NUMERICAL INDEX

PART NO.	REF. NO.	PART NO.	REF. NO.	PART NO.	REF. NO.	PART NO.	REF. NO.	PART NO.	REF. NO.	PART NO.	REF. NO.
18P-11102-00	1 - 1	3LD-12168-U1	3 - 13	18P-13543-00	9 - 16	2S2-15388-00	11 - 15	5YT-18113-00	16 - 27	18P-2163E-00	19 - 16
5VY-11111G-00	1 - 19	3LD-12168-W1	3 - 13	8FP-13556-00	9 - 2	18P-15393-01	12 - 47	18P-18122-00	16 - 20	18P-2163F-00	19 - 17
5TA-11133-10	1 - 2	3LD-12168-Y1	3 - 13	18P-13597-00	8 - 1	18P-15411-00	12 - 1	2S2-18140-10	16 - 4	18P-21643-00	19 - 8
5TA-11134-10	1 - 3	3LD-12169-11	3 - 13	18P-13750-00	9 - 1	18P-15413-00	12 - 52	5BE-18172-00	16 - 24	18P-21644-00	19 - 10
18P-11166-00	1 - 21	3LD-12169-31	3 - 13	3B4-13761-00	9 - 3	5TG-15415-00	12 - 25	3XJ-18173-10	16 - 18	18P-2164F-00	19 - 19
18P-11167-00	1 - 20	3LD-12169-50	3 - 13	18P-13843-00	8 - 7	18P-1541A-00	12 - 53	3XJ-18178-00	16 - 19	18P-2164G-00	19 - 27
2S2-11181-00	1 - 13	3LD-12169-70	3 - 13	18P-13907-00	25 - 15	18P-15421-00	12 - 18	3XJ-18182-00	16 - 21	18P-2164H-00	19 - 20
2S2-11190-20	1 - 16	3LD-12169-90	3 - 13	18P-13971-00	25 - 21	18P-15423-00	12 - 12	3XJ-18184-00	16 - 23	18P-2164J-00	19 - 28
2S2-11193-00	1 - 23	3LD-12169-E0	3 - 13	8FP-14137-00	9 - 15	18P-15431-00	12 - 21	2S2-18185-00	16 - 3	18P-21652-00	19 - 15
2S2-11311-10	1 - 24	3LD-12169-G0	3 - 13	2H0-14147-00	9 - 14	5TA-15441-01	12 - 16	18P-18511-00	16 - 8	18P-2165A-60	44 - 5
2S2-11351-00	1 - 25	3LD-12169-J0	3 - 13	5LP-14147-00	9 - 11	18P-15451-00	12 - 8	18P-18512-00	16 - 9	18P-2165A-70	44 - 5
18P-11395-00	1 - 28	3LD-12169-L0	3 - 13	5PS-14147-00	9 - 4	18P-15453-00	12 - 26	18P-18513-00	16 - 10	18P-2165A-80	44 - 5
18P-11400-00	2 - 1	3LD-12169-N0	3 - 13	1UY-14155-00	9 - 13	18P-15462-00	12 - 41	18P-18531-00	16 - 11	18P-2165A-90	44 - 5
18P-11412-00	2 - 2	3LD-12169-T0	3 - 13	1S3-14161-00	9 - 12	18P-15463-00	12 - 13	1WG-18531-01	16 - 12	18P-21691-00	19 - 26
18P-11422-00	2 - 3	18P-12170-00	4 - 1	8CC-14216-10	9 - 6	18P-15484-00	12 - 51	18P-18541-00	16 - 1	4SH-21697-00	48 - 8
18P-11454-00	2 - 14	18P-12180-00	4 - 2	18P-14348-00	9 - 17	18P-15515-00	13 - 5	2S2-18562-00	11 - 16	18P-21711-00	20 - 19
18P-11455-00	2 - 10	5TA-12210-10	4 - 5	18P-14409-00	8 - 28	18P-15517-00	13 - 4	41R-21101-09	17 - 1	41R-21717-00	17 - 20
18P-11531-00	2 - 11	4FM-12213-00	4 - 6	18P-14411-00	8 - 8	18P-15521-00	13 - 3	18P-2111A-00	17 - 33	18P-2171A-00	20 - 15
18P-11536-00	2 - 8	18P-12233-00	4 - 12	18P-14412-00	8 - 16	18P-15560-00	13 - 1	18P-21131-00	17 - 37	18P-2171A-10	20 - 15
5TG-11603-00	2 - 19	5BE-12241-00	1 - 17	18P-1442F-00	8 - 19	5TJ-15590-09	13 - 6	18P-21190-09	17 - 2	3YX-2171L-00	17 - 43
5TG-11631-11	2 - 18	2S2-12251-00	4 - 9	18P-14435-00	8 - 29	2S2-16111-60	14 - 1	18P-21715-00	17 - 6	18P-21721-00	20 - 20
5TG-11633-10	2 - 20	18P-12252-00	4 - 10	5GH-14436-00	8 - 12	18P-16150-00	14 - 4	18P-21316-00	17 - 11	18P-21731-10	20 - 22
18P-11651-00	2 - 6	18P-12405-00	6 - 2	5TG-14451-00	8 - 13	5XD-16154-00	14 - 12	18P-21317-00	17 - 12	18P-21731-20	20 - 22
18P-11681-00	2 - 4	18P-1240A-00	6 - 1	5KM-14452-00	8 - 17	5TA-16321-00	14 - 8	18P-21335-00	17 - 34	18P-2173L-00	44 - 6
5TA-12111-00	3 - 1	18P-12422-00	5 - 6	18P-14453-00	8 - 11	5VY-16321-00	14 - 9	18P-21336-00	17 - 35	18P-2173L-20	44 - 6
5TA-12112-00	3 - 2	18P-12428-00	5 - 7	59V-14457-00	8 - 24	4X7-16325-00	14 - 7	18P-2133H-00	17 - 4	18P-2173T-00	19 - 7
5TJ-12113-00	3 - 5	4C8-12438-00	5 - 3	5TG-14458-00	8 - 14	18P-16342-00	14 - 22	18P-21471-00	17 - 19	18P-2173U-00	19 - 6
5TA-12114-00	3 - 6	18P-1243A-00	12 - 30	5D3-14459-00	8 - 22	2S2-16351-00	14 - 6	18P-21513-00	18 - 6	18P-21741-10	20 - 23
4GY-12117-00	3 - 8	18P-12450-00	5 - 1	4ES-14462-00	8 - 23	5TG-16356-00	14 - 15	18P-21514-00	18 - 7	18P-21741-20	20 - 23
5BE-12117-00	3 - 7	5SL-12462-00	6 - 5	18P-14479-00	8 - 15	18P-16357-00	14 - 20	5FE-2151H-01	45 - 14	5MP-21747-00	42 - 39
1AA-12118-00	3 - 9	18P-12467-00	20 - 13	5YP-14562-00	9 - 9	5TA-16371-10	14 - 5		47 - 10	2S2-2177M-00	17 - 40
1WG-12118-00	3 - 10	5TG-12481-00	6 - 6	18P-14611-00	10 - 1	18P-16382-00	14 - 21		48 - 12	18P-21781-10	44 - 7
33M-12119-00	3 - 11	5BE-12564-00	12 - 55	3VD-14613-01	10 - 6	18P-17121-00	15 - 8	4LB-2151H-02	48 - 16	18P-21782-10	44 - 8
4SV-12119-00	3 - 12	18P-12576-00	6 - 9	18P-14628-00	10 - 2	18P-17131-00	15 - 7	4WU-2151H-10	45 - 18	26H-21828-00	20 - 4
5TA-12121-00	3 - 3	18P-12577-00	6 - 10	18P-14710-00	10 - 8	18P-17141-00	15 - 6	4ES-2153E-20	44 - 3	18P-21871-00	20 - 1
3GM-12126-00	3 - 4	18P-12671-00	6 - 4	8FA-14714-10	10 - 9	18P-17151-00	15 - 3	4ES-2153E-40	44 - 3	18P-21875-00	20 - 3
3FV-12153-10	3 - 14	2S3-12675-00	6 - 3	18P-14718-00	10 - 10	18P-17211-00	15 - 21	4SH-21568-00	48 - 7	18P-22110-00	21 - 1
3LD-12168-00	3 - 13	583-13113-00	12 - 38	5BE-14788-00	10 - 14	18P-17221-00	15 - 12	5FE-21568-01	45 - 1	4X7-22129-00	21 - 8
3LD-12168-20	3 - 13	18P-13160-00	9 - 5	5JW-14945-00	9 - 8	18P-17231-00	15 - 15	4WU-21568-10	45 - 7	55K-22129-00	21 - 23
3LD-12168-40	3 - 13	18P-13300-00	7 - 1	18P-15100-00	11 - 1	18P-17241-00	15 - 19	5FE-21568-11	47 - 1		21 - 32
3LD-12168-60	3 - 13	5TA-13320-00	7 - 2	2S2-15155-10	11 - 3	18P-17251-00	15 - 20		48 - 1	18P-22141-00	21 - 10
3LD-12168-80	3 - 13	18P-13341-00	7 - 9	18P-1531A-00	8 - 34	18P-17402-00	15 - 11	18P-21569-30	44 - 1	3YF-22149-00	21 - 7
3LD-12168-A0	3 - 13	2S2-13342-00	7 - 7	18P-1532A-00	8 - 36	18P-17411-00	15 - 2	18P-21569-40	44 - 1	1C3-2214F-00	17 - 41
3LD-12168-F0	3 - 13	18P-13411-00	7 - 13	18P-15362-00	12 - 6	18P-17460-00	15 - 27	18P-2159A-30	44 - 2	18P-22151-10	21 - 36
3LD-12168-H1	3 - 13	18P-13412-01	7 - 12	18P-15370-00	8 - 32	18P-17466-00	12 - 19	18P-2159A-40	44 - 2	5TG-22153-10	21 - 39
3LD-12168-K1	3 - 13	18P-13421-00	7 - 16	18P-15378-00	11 - 25	1S3-17471-00	15 - 30	18P-21621-00	19 - 18	5TG-22178-00	17 - 22
3LD-12168-M1	3 - 13	5D3-13440-00	12 - 32	4JT-15381-01	11 - 11	18P-18101-00	16 - 13	4XY-21638-00	17 - 39	18P-2217A-00	21 - 16
3LD-12168-R1	3 - 13	5BE-13447-10	12 - 33	18P-15383-00	11 - 12	18P-18110-00	16 - 26	18P-2163A-00	19 - 39	18P-2217F-00	21 - 28

NUMERICAL INDEX

PART NO.	REF. NO.	PART NO.	REF. NO.	PART NO.	REF. NO.	PART NO.	REF. NO.	PART NO.	REF. NO.	PART NO.	REF. NO.
18P-22210-10	22 - 1	5TG-2415E-10	47 - 13	3GD-2582T-10	28 - 1	1UY-25974-51	30 - 9	5D3-2816M-M0	46 - 7	5RU-8252U-00	42 - 77
18P-22210-20	22 - 1	5PW-2415E-11	45 - 20	1S3-2582W-20	30 - 1	5TG-25975-00	30 - 6	1AS-2816P-00	46 - 10	18P-82530-00	42 - 62
18P-22210-50	22 - 1	5PW-2415E-31	45 - 21	5MV-25833-00	32 - 7	5TG-25977-50	30 - 20	43P-2816R-00	46 - 1	3GB-82540-01	42 - 18
18P-22210-60	22 - 1	3FB-2415E-C1	48 - 17	5UG-25833-00	30 - 7	5TG-25978-00	30 - 8	4D3-2817J-00	45 - 9	18P-82541-00	42 - 44
18P-22210-A0	22 - 1	4SH-2416E-00	45 - 19	5D3-2583T-00	32 - 1	5D3-26111-10	31 - 1	4D3-2817J-10	45 - 10	18P-8254E-00	42 - 75
4AA-22259-40	22 - 2	1S3-24486-00	25 - 17	5D3-25852-00	32 - 4	18P-26124-00	31 - 30	18P-28215-00	35 - 9	5ND-82560-00	42 - 59
	24 - 29	18P-24491-00	25 - 16	3XP-25852-50	34 - 20	1NV-26129-00	31 - 16	5TG-28215-00	35 - 8	3HN-82569-00	42 - 49
4AA-22259-50	22 - 2	5KM-24610-00	25 - 2	2VN-25854-00	34 - 21	5D3-26219-10	31 - 31	4XY-28347-00	17 - 42	5PS-82576-01	42 - 68
	24 - 29	18P-2464V-00	25 - 19	4TT-25854-00	32 - 3	18P-2622H-00	31 - 5	4KN-2836B-10	44 - 4	3HN-82579-00	42 - 48
4AA-22259-70	22 - 2	18P-2467E-00	25 - 20	2VN-25855-00	34 - 22	5LP-26241-00	31 - 4	2CO-28372-00	42 - 56	18P-82590-00	42 - 57
	24 - 29	18P-2470F-00	26 - 2	2GU-25866-00	32 - 20	1S3-26250-00	31 - 7	18P-2845N-00	35 - 1	18P-82590-10	42 - 57
18P-22361-00	21 - 38	18P-2470F-20	26 - 2	5LP-25867-00	32 - 6	1UY-26259-00	31 - 25	18P-2845N-10	35 - 1	18P-82910-00	41 - 2
5TG-22475-00	21 - 15	18P-24710-00	26 - 1	18P-25871-10	32 - 17	1NV-26259-01	31 - 13	18P-2845R-00	35 - 3	5TG-82911-00	41 - 3
18P-2247A-00	25 - 13	18P-24710-20	26 - 1	18P-25872-10	32 - 12	1S3-2625G-00	31 - 17	18P-2845R-10	35 - 3	1S3-82913-00	31 - 21
1S3-23147-01	21 - 49	18P-24723-00	26 - 7	18P-25873-10	32 - 13	1NV-2625K-00	31 - 14	4D9-81168-00	42 - 23	5TG-82913-00	41 - 10
18P-23317-00	34 - 32	3KJ-24723-00	17 - 38	18P-25874-00	34 - 27	1S3-2628F-00	31 - 8	18P-81410-00	36 - 1	5KM-82917-00	41 - 9
18P-23350-10	24 - 28	214-24724-00	26 - 4	18P-25875-00	32 - 14	1S3-2628G-00	31 - 9	18P-81450-00	36 - 2	18P-83530-00	42 - 50
18P-23350-20	24 - 28	18P-24725-00	26 - 6	18P-25876-00	32 - 15	1NV-26304-00	31 - 12	18P-81528-00	36 - 3	18P-8361L-00	42 - 51
18P-23350-80	24 - 28	22W-24741-00	20 - 16	18P-25886-00	34 - 30	18P-26311-00	31 - 24	18P-81801-00	37 - 2	18P-83755-00	42 - 22
18P-23350-90	24 - 28		26 - 5	5JJ-25894-01	34 - 19	18P-26335-00	31 - 27	18P-81815-00	37 - 7	5TJ-83912-00	41 - 4
18P-23350-A0	24 - 28	18P-2476U-00	19 - 2	18P-25895-00	34 - 16	5TA-26337-00	41 - 6	18P-81826-00	37 - 3	5D3-83922-00	32 - 8
18P-23441-00	23 - 11	18P-2476V-00	19 - 3	18P-25897-00	34 - 23	18P-26341-00	31 - 29	4XV-8182A-00	37 - 6	5TG-83923-00	41 - 15
18P-23442-10	23 - 12	1S3-25111-00	27 - 7	3B4-2589F-00	32 - 11	1C3-26342-50	31 - 28		37 - 8	437-83936-01	31 - 32
18P-23501-00	24 - 37	5LP-25117-00	27 - 9	4NK-2589H-00	32 - 5	5TG-26372-00	31 - 26	4B5-81844-00	37 - 4	5HD-83951-00	41 - 8
18P-23502-00	24 - 38	1S3-25127-00	27 - 22	3SP-25914-51	30 - 16	1NV-26398-00	31 - 11	1FK-81847-00	37 - 5	1S3-83973-11	41 - 1
5YT-23517-00	24 - 18	5TG-2514A-00	28 - 32	3JD-25917-00	28 - 7	371-27114-00	26 - 3	18P-81890-00	37 - 1	5D3-83980-00	32 - 10
	24 - 19	1S3-25180-11	27 - 1		28 - 21	18P-27211-00	33 - 8	18P-81940-00	42 - 45	5TG-84110-03	38 - 2
18P-23540-00-33	24 - 7		27 - 4		30 - 17	18P-27217-00	33 - 9	18P-81948-00	42 - 11	18P-8411K-00	39 - 6
18P-23550-00-33	24 - 10	5TG-25311-20	21 - 45	3JD-25919-00	28 - 8	4SS-27218-00	34 - 8	5DM-81950-00	42 - 67		40 - 6
18P-23570-00-33	24 - 1	5TG-25317-00	21 - 48		28 - 22	2YK-27222-00	34 - 9	5EA-81950-20	42 - 65	5TG-84140-01	38 - 4
5LP-23579-00	24 - 2	18P-25381-00	29 - 17	5TG-25924-00	28 - 15	18P-27263-00	34 - 25	5EA-81952-00	42 - 66	18P-84165-00	38 - 3
	24 - 5	18P-25383-00	29 - 4		28 - 29	18P-27411-00	33 - 1	5BN-81960-00	42 - 25	18P-84166-00	38 - 11
	24 - 8	18P-25386-00	29 - 11	3JD-25926-00	28 - 12	4HC-27415-00	42 - 40	3WP-81980-00	42 - 61	5TG-84310-03	38 - 10
	24 - 11	1S3-25390-11	29 - 1		28 - 26	18P-27421-00	33 - 4	4WA-81980-00	42 - 60	4KB-84314-01	38 - 1
18P-23580-00-33	24 - 4	18P-25415-00	29 - 21	1UY-25926-51	28 - 10	18P-2743E-00	34 - 31	5XT-82100-00	42 - 32		38 - 9
1UY-23812-00	23 - 16	5TG-25438-10	29 - 12		28 - 24	18P-27453-00	34 - 11	1S4-82100-10	42 - 32	5TG-84340-01	38 - 12
18P-23813-00	23 - 1	5D3-25689-00	41 - 13	3SP-25926-51	30 - 18	18P-28100-00	17 - 47	18P-82116-00	42 - 43	18P-84703-00	39 - 8
18P-23816-00	23 - 2	18P-25712-00	29 - 15	5DH-25933-00	30 - 14	1NV-2811A-01	17 - 48	18P-82122-00	42 - 33	1S3-84710-01	39 - 1
18P-23831-00	23 - 3	5TG-25721-20	21 - 50	3LD-25934-01	30 - 12	4D3-2816L-00	45 - 4	4D3-82122-00	42 - 38		40 - 1
1S3-23841-20	23 - 4	5TG-25726-00	41 - 14	1UY-25937-51	28 - 6		47 - 4	18P-82128-00	42 - 34	18P-84716-00	39 - 5
1S3-23845-20	23 - 5	5TG-25727-00	41 - 12		28 - 20		48 - 4	18P-82129-00	42 - 37		40 - 5
1UY-23868-01	23 - 18	1S3-2580E-00	34 - 1		30 - 15	4D3-2816L-10	45 - 8	18P-8212B-00	42 - 71	18P-84751-00	39 - 11
5GT-23872-00	17 - 30	5TG-2580T-11	28 - 3	1UY-25938-51	28 - 11	4D3-2816L-20	46 - 4	5ND-82180-00	42 - 58	2EK-85111-00	43 - 7
1UY-23894-01	23 - 20	5TG-2580U-11	28 - 17		28 - 25	5D3-2816M-00	45 - 11	18P-82310-00	42 - 8	3Y6-85130-02	43 - 1
18P-24110-00	25 - 1	5TG-2580W-20	30 - 3	3JD-25961-00	28 - 13		47 - 7	18P-82370-00	42 - 10	449-85131-02	43 - 4
18P-24110-10	25 - 1	1S3-25828-00	28 - 16		28 - 27		48 - 9	5S7-82380-00	8 - 4	8CC-85790-01	42 - 20
18P-2414H-00	25 - 12		28 - 30	5TG-25972-00	30 - 11	5D3-2816M-10	45 - 17	18P-8246B-00	42 - 63	3B4-85885-00	9 - 7
5TG-2415E-00	46 - 13	1AE-2582A-00	34 - 3	1UY-25973-51	30 - 10	5D3-2816M-20	48 - 15	4SH-82510-00	42 - 47	8FP-85886-00	8 - 9

NUMERICAL INDEX

PART NO.	REF. NO.	PART NO.	REF. NO.	PART NO.	REF. NO.	PART NO.	REF. NO.	PART NO.	REF. NO.	PART NO.	REF. NO.
18P-8591A-10	42 - 1	90105-10301	24 - 21	90149-08044	30 - 2	90201-03008	47 - 3	90201-12034	23 - 15	90269-07076	20 - 14
18P-85991-00	42 - 3	90105-10339	24 - 30	90149-10034	17 - 3		47 - 6	90201-12166	7 - 11	90280-03006	2 - 17
18P-87208-00	42 - 27	90105-10350	17 - 15	90151-08003	11 - 13		47 - 9	90201-12516	14 - 17	90338-05008	42 - 16
5D3-W0041-00	32 - 2	90105-10351	24 - 33	90154-05013	19 - 21		47 - 12	90201-127E1	16 - 15	90338-07007	41 - 17
1S3-W0042-50	34 - 2	90105-12038	22 - 3		19 - 29		48 - 3	90201-14021	23 - 22	90338-08226	42 - 12
5TG-W0045-20	28 - 14	90105-12064	21 - 24	90154-06014	28 - 33		48 - 6	90201-14586	27 - 19	90338-12192	42 - 36
5TG-W0045-30	28 - 28	90105-12065	21 - 26	90159-06010	14 - 11		48 - 11	90201-15701	12 - 23	90338-16007	17 - 32
5TG-W0046-10	30 - 13	90105-12066	21 - 33	90170-12054	23 - 7		48 - 14	90201-16018	21 - 11	90338-20183	17 - 31
5TG-W0047-00	30 - 5	90108-05001	33 - 12	90170-12055	23 - 6	90201-04027	21 - 41	90201-16023	29 - 8	90338-23004	21 - 9
3LC-W0047-50	28 - 5	90109-06031	16 - 28	90170-14171	2 - 12	90201-04028	8 - 21	90201-20022	27 - 17	90340-12007	1 - 5
	28 - 19	90109-06034	41 - 5	90170-20327	14 - 14	90201-04030	42 - 70	90201-20276	15 - 22	90340-14011	12 - 4
1UY-W0048-50	28 - 9	90109-06172	20 - 27	90171-10001	23 - 8	90201-05015	10 - 3	90201-22015	15 - 28	90340-36002	12 - 2
	28 - 23		21 - 37		24 - 40		10 - 12	90208-25045	14 - 2	90380-10002	11 - 4
	30 - 19	90109-06198	16 - 6	90171-14002	27 - 20	90201-06013	16 - 7	90208-39001	29 - 19	90380-22111	21 - 3
5TG-W0057-00	28 - 4		17 - 21	90171-16002	29 - 9	90201-06033	18 - 4	90209-06096	8 - 26	90381-15088	24 - 13
	28 - 18	90109-06199	18 - 10	90179-12657	36 - 7		21 - 44	90209-10229	23 - 9		24 - 14
5TG-W0057-10	30 - 4	90109-06203	1 - 18	90179-20009	14 - 3		25 - 5		24 - 39	90387-02001	31 - 2
18P-W215B-01	18 - 1	90109-06249	19 - 40	90179-22018	15 - 29		25 - 8	90209-23012	15 - 4	90387-06063	35 - 5
18P-W215B-11	18 - 1	90109-067F4	32 - 16	90179-38001	29 - 18	90201-06076	19 - 25	90209-26008	15 - 13	90387-06136	38 - 6
18P-W215C-00	18 - 1	90109-08082	28 - 2	90183-060A6	42 - 13		19 - 33	90214-26002	15 - 16		38 - 14
18P-W215C-10	18 - 1	90109-10013	29 - 13	90183-061A5	18 - 2	90201-06078	38 - 8	90214-26003	15 - 17	90387-06151	21 - 43
18P-W215D-00	18 - 1	90110-06168	4 - 13		18 - 8		38 - 16	90215-14287	2 - 13	90387-06153	42 - 74
18P-W215D-10	18 - 1		13 - 7		19 - 12		42 - 30	90215-20005	14 - 13	90387-06161	42 - 15
18P-W216B-01	19 - 1		36 - 4		20 - 24		42 - 54	90240-08124	34 - 13	90387-06170	20 - 25
18P-W216B-11	19 - 1		36 - 6		35 - 10	90201-06085	18 - 5	90252-03001	29 - 10	90387-06197	17 - 46
18P-W216C-00	19 - 1	90110-06169	36 - 5	90185-10011	17 - 16		19 - 14	90267-24143	31 - 3	90387-06204	39 - 3
18P-W216C-10	19 - 1	90110-06208	7 - 14		17 - 18		20 - 18	90267-32004	19 - 4		40 - 3
18P-W216D-00	19 - 1	90110-06228	12 - 36		29 - 14	90201-08043	17 - 24		45 - 2		42 - 29
18P-W216D-10	19 - 1	90110-10029	17 - 9	90185-10012	24 - 24		19 - 38		45 - 5		42 - 53
18P-W8211-10	42 - 41	90110-12001	21 - 54		24 - 25	90201-08048	10 - 16		45 - 12	90387-06205	19 - 23
90101-05033	41 - 11	90111-06038	18 - 3		24 - 31		19 - 35		45 - 15		19 - 31
90101-06041	16 - 25		19 - 13		24 - 35	90201-08053	17 - 8		46 - 2	90387-06257	25 - 9
90102-12005	22 - 7		20 - 17	90185-12002	21 - 25	90201-08077	33 - 10		46 - 5	90387-06258	25 - 4
90105-06027	1 - 4	90111-06059	39 - 9		21 - 27	90201-08083	34 - 14		46 - 8	90387-06388	42 - 5
90105-06063	34 - 33	90111-06084	20 - 26		22 - 5	90201-10025	1 - 15		46 - 11	90387-07030	4 - 11
90105-06081	11 - 17		42 - 17		23 - 14	90201-10032	14 - 23		47 - 2	90387-07391	6 - 14
90105-06084	8 - 31	90113-06055	29 - 20	90185-12007	21 - 34	90201-10035	24 - 32		47 - 5	90387-08073	8 - 30
	17 - 45	90114-10006	27 - 8	90185-14009	23 - 23	90201-10036	17 - 10		47 - 8	90387-086N4	17 - 25
	42 - 35	90114-10013	29 - 5	90185-16002	21 - 12	90201-10037	24 - 22		47 - 11	90387-090R0	23 - 21
	42 - 73	90116-08022	1 - 11	90201-03008	19 - 5		24 - 23		48 - 2	90387-10043	24 - 17
90105-08112	17 - 26	90119-06152	20 - 2		45 - 3		24 - 36		48 - 5		24 - 34
90105-08129	10 - 15	90119-06177	34 - 24		45 - 6	90201-10043	17 - 14		48 - 10	90387-10069	24 - 16
90105-08154	23 - 13	90119-06181	6 - 15		45 - 13	90201-10118	32 - 22		48 - 13	90387-101R3	24 - 15
90105-08184	28 - 31	90122-06010	8 - 27		45 - 16		34 - 28	90267-47187	21 - 40	90387-12041	21 - 21
90105-10135	24 - 20	90149-04278	31 - 18		46 - 3	90201-12020	36 - 8	90267-48025	8 - 20	90387-12042	21 - 30
90105-10148	17 - 17	90149-06069	2 - 15		46 - 6	90201-12032	21 - 35	90267-48176	17 - 5	90387-12043	21 - 19
90105-10163	1 - 14		7 - 8		46 - 9		22 - 4	90269-05001	17 - 36	90387-12046	22 - 6
90105-101A9	30 - 21	90149-06074	11 - 14		46 - 12	90201-12034	22 - 8	90269-07010	20 - 21	90387-150R1	27 - 18

NUMERICAL INDEX

PART NO.	REF. NO.	PART NO.	REF. NO.	PART NO.	REF. NO.	PART NO.	REF. NO.	PART NO.	REF. NO.	PART NO.	REF. NO.
90387-16014	21 - 55	90467-14057	34 - 18	91401-16012	34 - 15	93210-07135	12 - 35	93700-06004	24 - 26	95702-10500	27 - 14
90387-16027	21 - 5	90467-140A6	8 - 35	91402-20020	23 - 10	93210-10197	11 - 19		24 - 27		29 - 6
90387-160W1	21 - 6		8 - 37		24 - 41	93210-14369	12 - 5	93900-00022	29 - 3	95802-06020	42 - 26
90387-164N2	11 - 20		12 - 50	91402-20025	23 - 24	93210-15620	34 - 4	93900-00030	27 - 3	95802-06025	38 - 7
90387-17013	23 - 26	90467-220A1	8 - 25	91402-30025	22 - 9	93210-16500	6 - 8		27 - 6		38 - 15
90387-176R6	23 - 25	90467-23109	6 - 11		27 - 21	93210-19026	12 - 7	94107-10025	27 - 2		42 - 31
90387-20005	27 - 16	90468-100A1	1 - 22	91808-16023	1 - 6	93210-19758	12 - 56		27 - 5	95812-06016	42 - 2
90387-26005	15 - 18	90468-16191	33 - 11		1 - 7	93210-25001	15 - 26	94110-09025	29 - 2	95812-06020	35 - 6
90387-28009	15 - 25	90480-01559	18 - 9	92012-06012	39 - 12	93210-357A3	12 - 3	94582-13098	29 - 23		42 - 6
90387-40001	29 - 16	90480-10289	35 - 4	92012-06014	41 - 16	93210-37003	29 - 22	94591-57120	4 - 4	95812-06025	21 - 42
90401-10015	32 - 21		42 - 28	92012-06025	42 - 55	93210-47675	12 - 34	94701-00330	1 - 12	95812-06030	25 - 10
	34 - 29		42 - 52	92012-06030	19 - 22	93210-66001	21 - 52	94703-00330	1 - 12	95812-06110	8 - 33
90430-06014	1 - 9	90480-11006	31 - 6		19 - 30	93210-71001	21 - 51	95022-06008	42 - 46	95812-08020	35 - 2
	4 - 8	90480-12007	42 - 72	92012-06040	25 - 6	93300-60804	17 - 23	95022-06010	1 - 8		35 - 7
	5 - 10	90480-14011	42 - 4	92012-08012	34 - 12	93304-20812	21 - 46		42 - 64	95812-10030	17 - 13
	11 - 27	90480-14102	38 - 5	92012-08016	19 - 9	93306-00106	5 - 5	95022-06012	6 - 7	95812-12025	33 - 2
90430-10148	11 - 10		38 - 13		19 - 11	93306-00426	15 - 10		11 - 26	95812-12035	33 - 5
	42 - 19	90480-14323	39 - 2	92012-08020	19 - 37	93306-00446	27 - 10		34 - 26	95812-12055	33 - 3
90430-12202	42 - 21		40 - 2	92012-08035	34 - 10	93306-20231	27 - 11	95022-06014	15 - 31	95812-12065	33 - 6
90445-08008	25 - 11		42 - 14	92014-06016	41 - 18	93306-20332	15 - 9	95022-06020	12 - 15	95822-06035	32 - 18
90445-09123	20 - 9	90480-15058	6 - 13	92902-05100	31 - 23	93306-20352	17 - 27	95022-06025	4 - 7	95822-08025	19 - 34
90445-09251	20 - 8	90480-18004	25 - 3		43 - 2	93306-20353	2 - 9		37 - 9	97012-08035	17 - 7
90445-11418	17 - 44	90480-18290	25 - 7		43 - 5	93306-20532	15 - 1	95022-06030	5 - 9	97022-08065	23 - 19
90450-32015	6 - 12	90501-043E0	12 - 40		43 - 9	93306-27803	15 - 23		12 - 28	97702-50025	39 - 4
90450-54009	8 - 6	90501-052G5	16 - 22	92902-05200	43 - 8	93306-30644	2 - 7		12 - 44		40 - 4
90450-58005	8 - 3	90501-231E9	14 - 10	92902-06200	10 - 13	93306-90509	16 - 2	95022-06035	1 - 10	97702-60125	8 - 5
90450-99014	8 - 18	90506-25001	33 - 7	92902-10200	27 - 15	93310-11268	13 - 2		1 - 27		42 - 9
90461-10135	11 - 23	90508-16061	14 - 28		29 - 7	93310-73606	2 - 5		12 - 11	98502-05010	8 - 10
90462-10056	11 - 22	90508-26021	16 - 5	92903-08600	21 - 14	93311-62574	2 - 16	95022-06040	12 - 29	98502-05020	31 - 20
90464-08051	12 - 49	90508-32136	16 - 14	92906-04100	34 - 6	93315-31758	21 - 20		12 - 43		31 - 22
90464-12001	42 - 42	90520-08001	25 - 14	92906-04600	34 - 7		21 - 29	95022-06065	12 - 10	98506-04012	34 - 5
90464-12036	42 - 7	91312-04006	9 - 18	92990-06200	10 - 5	93315-32056	21 - 17	95022-06080	12 - 46	98507-06012	9 - 10
90464-13073	42 - 79	91312-04025	42 - 69	93101-12173	5 - 4	93317-11287	14 - 25	95022-10016	11 - 9	98902-06010	10 - 11
90464-15065	20 - 11	91312-06014	1 - 29	93101-14164	12 - 22	93317-22237	21 - 2	95302-05600	43 - 3	98980-06010	10 - 4
90464-15157	39 - 7	91312-06016	11 - 8	93102-12224	14 - 26	93340-21505	14 - 16		43 - 6	99009-10400	14 - 24
	40 - 7		11 - 24		16 - 17	93410-26067	15 - 5	95302-05700	31 - 19	99009-12400	5 - 2
90464-15M08	20 - 12		12 - 17	93102-22216	27 - 13	93410-67085	21 - 53	95302-06800	25 - 18		7 - 10
90464-16001	20 - 10		12 - 48	93102-25081	17 - 28	93440-10085	14 - 18	95312-06600	32 - 19	99009-20500	14 - 27
	31 - 33		12 - 54	93102-25099	17 - 29	93440-10153	7 - 4	95602-05100	31 - 10	99009-22500	12 - 24
90465-08127	12 - 45		42 - 24	93102-35393	15 - 24	93440-28062	15 - 14	95602-05200	33 - 13	99009-30400	24 - 3
90465-10098	42 - 76	91312-06020	8 - 2	93104-09025	31 - 15	93440-41178	4 - 3	95602-06100	41 - 7		24 - 6
90465-13M11	42 - 78		12 - 37	93105-26026	27 - 12	93450-22027	2 - 21	95602-06200	19 - 24		24 - 9
90467-070A0	12 - 31	91312-06025	12 - 20	93106-22019	21 - 4	93503-08007	12 - 39		19 - 32		24 - 12
90467-08003	20 - 6	91312-06030	7 - 6	93106-48001	21 - 47	93515-32029	14 - 19		39 - 10	99530-08012	7 - 5
	20 - 7	91312-06050	11 - 5	93109-17071	21 - 22	93603-16219	7 - 3		39 - 13		12 - 14
90467-11019	20 - 5	91312-06060	11 - 6		21 - 31	93604-10011	5 - 8	95602-08200	19 - 36	99530-08016	12 - 9
90467-11044	34 - 17	91312-06080	11 - 7	93109-20001	21 - 18	93608-30002	16 - 16	95604-06100	32 - 9		12 - 27
90467-12052	8 - 38	91314-08040	21 - 13	93112-31011	23 - 17	93612-16254	1 - 26	95702-08500	10 - 7	99530-10114	7 - 15

NUMERICAL INDEX

PART NO.	REF. NO.	PART NO.	REF. NO.	PART NO.	REF. NO.	PART NO.	REF. NO.	PART NO.	REF. NO.
99530-10114	11 - 18								
99530-10120	12 - 42								
99530-14016	11 - 2								
	11 - 21								

